



Heatsink Grounding Simulation Example with HFSS

Jim DeLap

Ansoft EMI/EMC Seminar

08/22/2007



Overview

- Standard problem investigating heatsink grounding
- With many high speed signals running through high-current chips, heatsinks can be a major generator of EMI.
- This presentation will go over the comparisons of different via strategies, and how they help reduce emissions.

Standard Problem

- The standard heatsink problem is defined in the following paper:
- “Comparison of Various Numerical Modeling Tools Against a Standard Problem Concerning Heat Sink Emissions,” B. Archambeault, S. Pratapneni, L. Zhang, D. Wittwer
- This is published as part of a standard EMI problem set on the following website:
 - <http://www.ewh.ieee.org/cmte/tc9/>

Standard Heatsink

- All ground plane and heatsink dimensions specified
- Heatsink and ground vias modeled as solid perfect conductor objects
- Grounding vias placed in various locations to investigate effective frequency range of emissions
- All simulations, unless noted, were performed with Ansoft HFSS v11

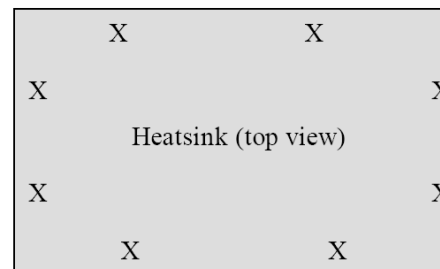
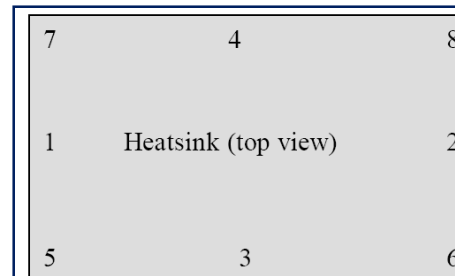
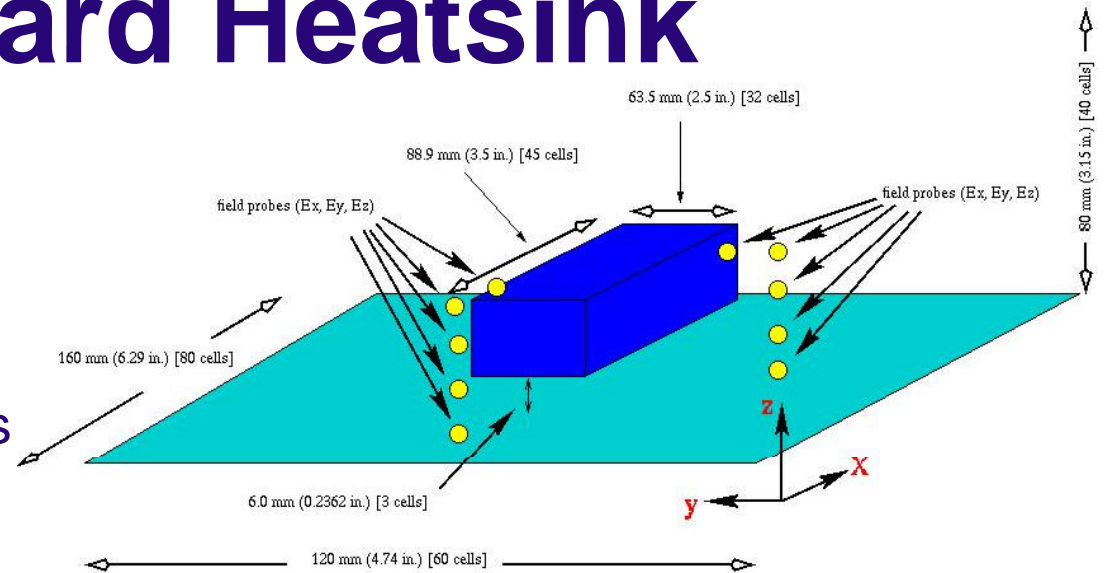

- One Ground Point #1
- Two-end Ground Points #1,2
- Two-side Ground Points #3,4
- Four Edge Centered Ground Points #1,2,3,4
- Four Corner Ground Points #5,6,7,8

Eight Ground Points

Heatsink Stimulus

- Excitation “method” left up to users of individual electromagnetic solvers
- Excitation position fixed as slightly offset from center of heatsink
 - To excite multiple modes of heatsink
- Current source was chosen for simplicity
 - Excited 1 A of current between heatsink and ground plane

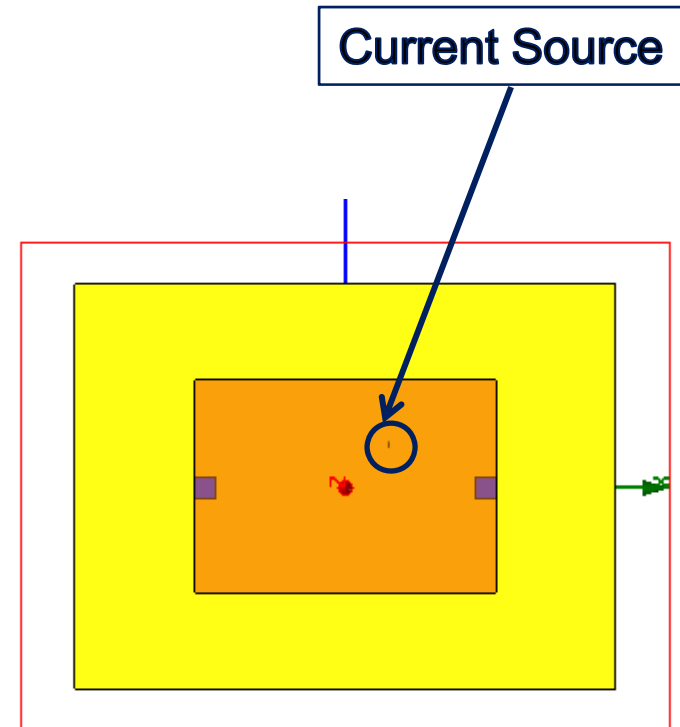

Heatsink Observation

- Field probes were not explicitly called out in paper
- Observation quantities were not explicitly defined either
- Two points were chosen to monitor the field values – (80mm, 0, 44.1mm) & (0mm, 60mm, 44.1mm)

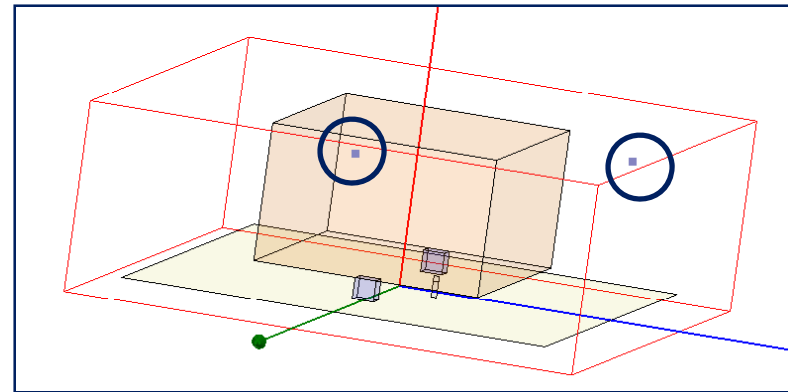
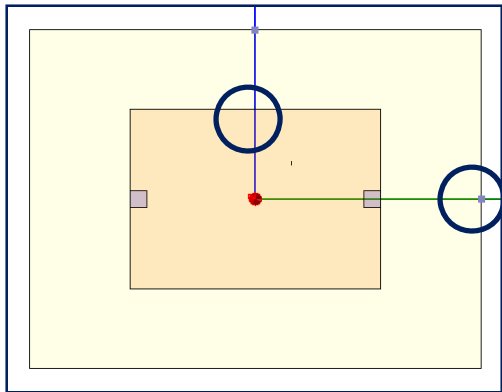

- The cmplxMag of E_x , E_y , and E_z were monitored at both of these points

Heatsink Calculations

- Generating an absolute EMI measurement is extremely difficult
- An “Advantage” quantity is defined for the purposes of this investigation
- Using the heatsink problem with NO grounds as the reference:
 - $\text{Advantage(dB)} = \text{reference(dB)} - \text{trial(dB)}$
- This should mitigate differences between tools in stimulus and observation methods

Heatsink – 1 Ground

- To determine the best observation quantity and position, the various advantage curves were overlaid with the paper results.
- $\text{cmplxMag}(E_{\text{total}})$ for 2 points was also added to the observation quantities

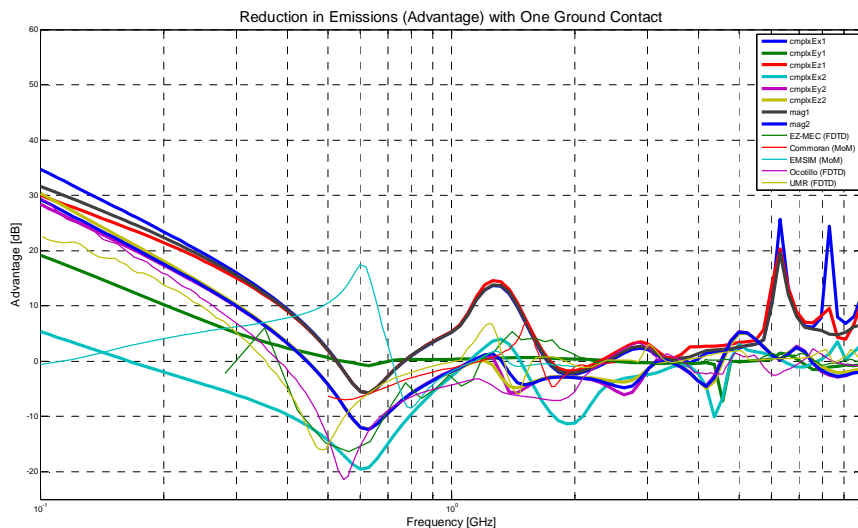

While most observations followed the trend nicely, $\text{cmplxMag}(E_{\text{total}})$ at observation point 2 matched the best, and was used throughout the rest of the trials.

Comparison – 1 Ground

Reduction in Emissions (Advantage) with One Ground Contact

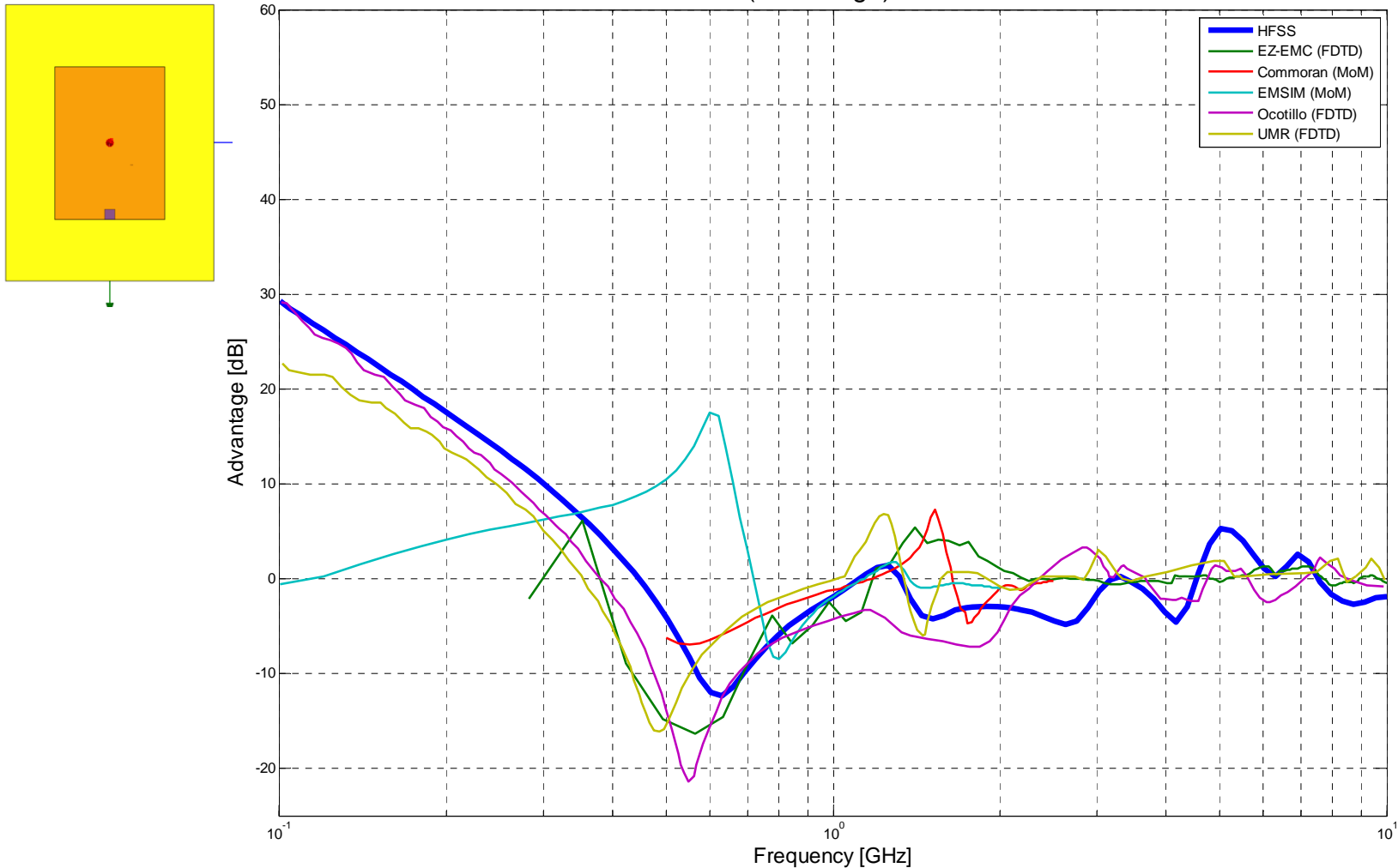

Conclusions for 1 Ground

- One ground via provides an “advantage,” or reduction in emissions over no grounds, for frequencies up to 450 MHz.

Heatsink – 2 Side Grounds

- Ground vias now placed on either long side of the heatsink
- This increases the effective frequency range to 700 MHz

Comparison – 2 Side Grounds

Reduction in Emissions (Advantage) with Two Long-Side Ground Contacts

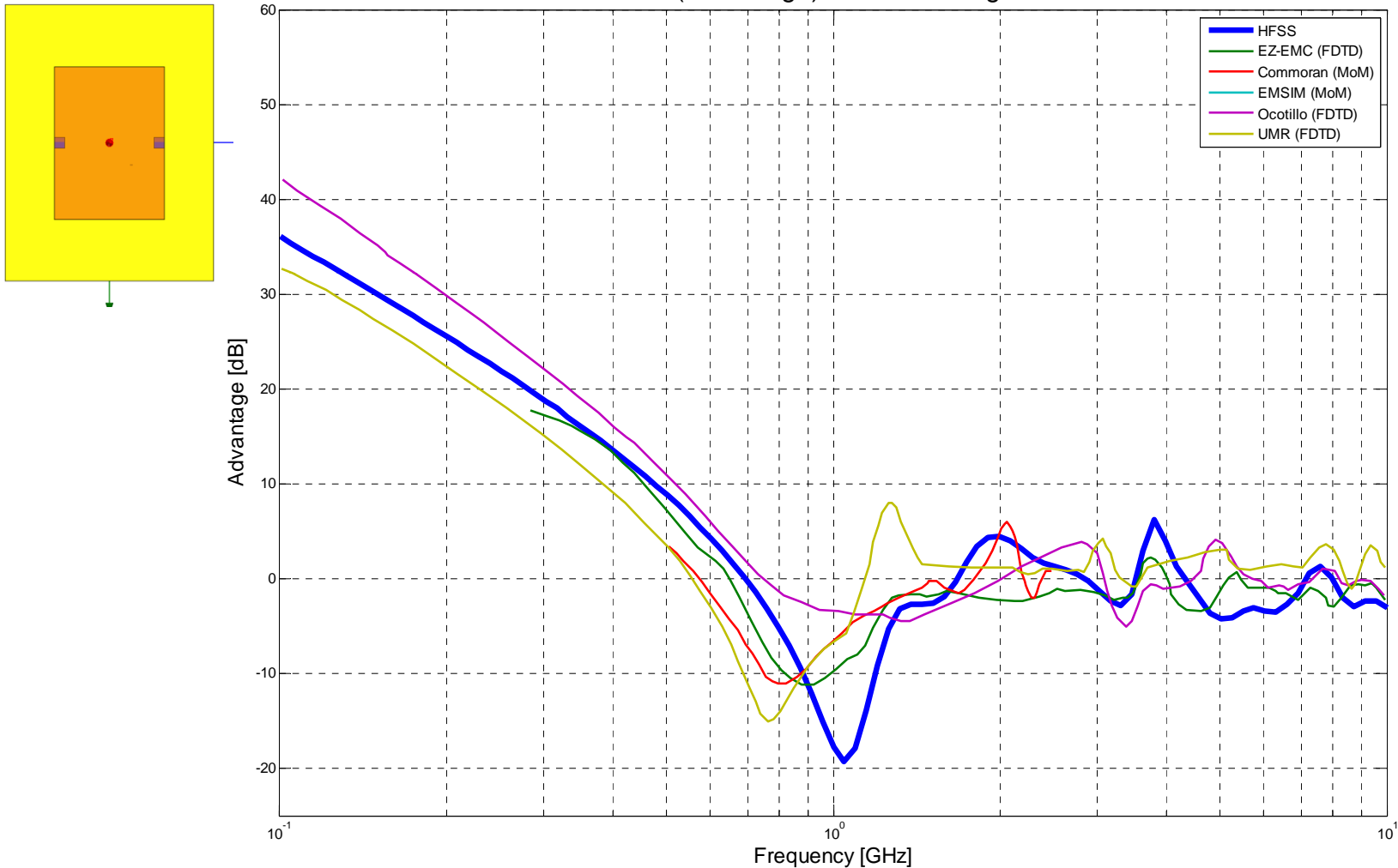

Heatsink – 4 Corner Grounds

- Ground vias added to all four corners of heatsink
- Pushes the frequency advantage to 900 MHz

Comparison – 4 Corner Grounds

Reduction in Emissions (Advantage) with Four Corner Ground Contacts

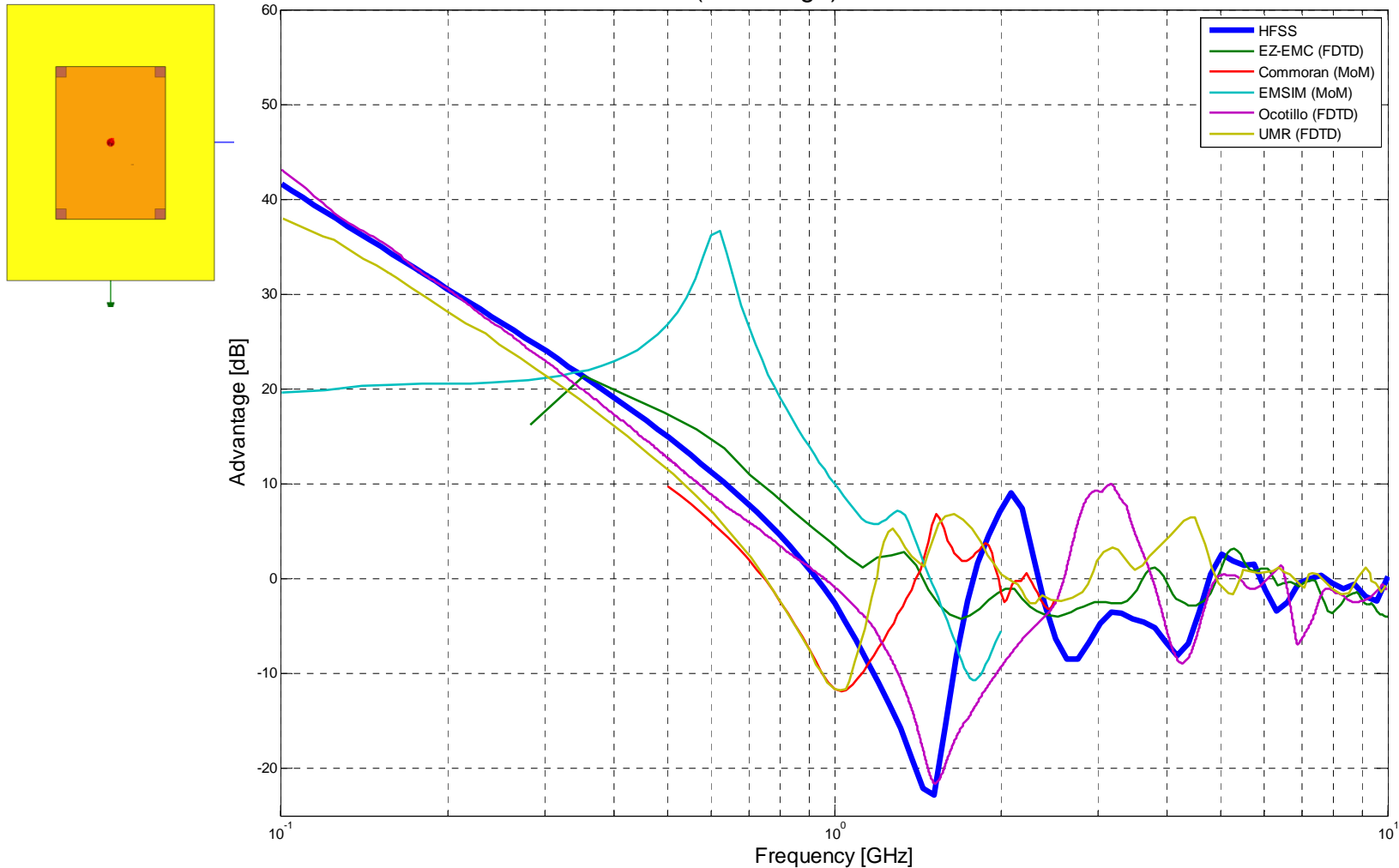

Heatsink – 8 Grounds

- For this example, ground vias removed from corners, and multiple vias placed along sides of heatsink
- Improved effectiveness range to > 2 GHz

Comparison – 8 Grounds

Reduction in Emissions (Advantage) with Eight Ground Contacts

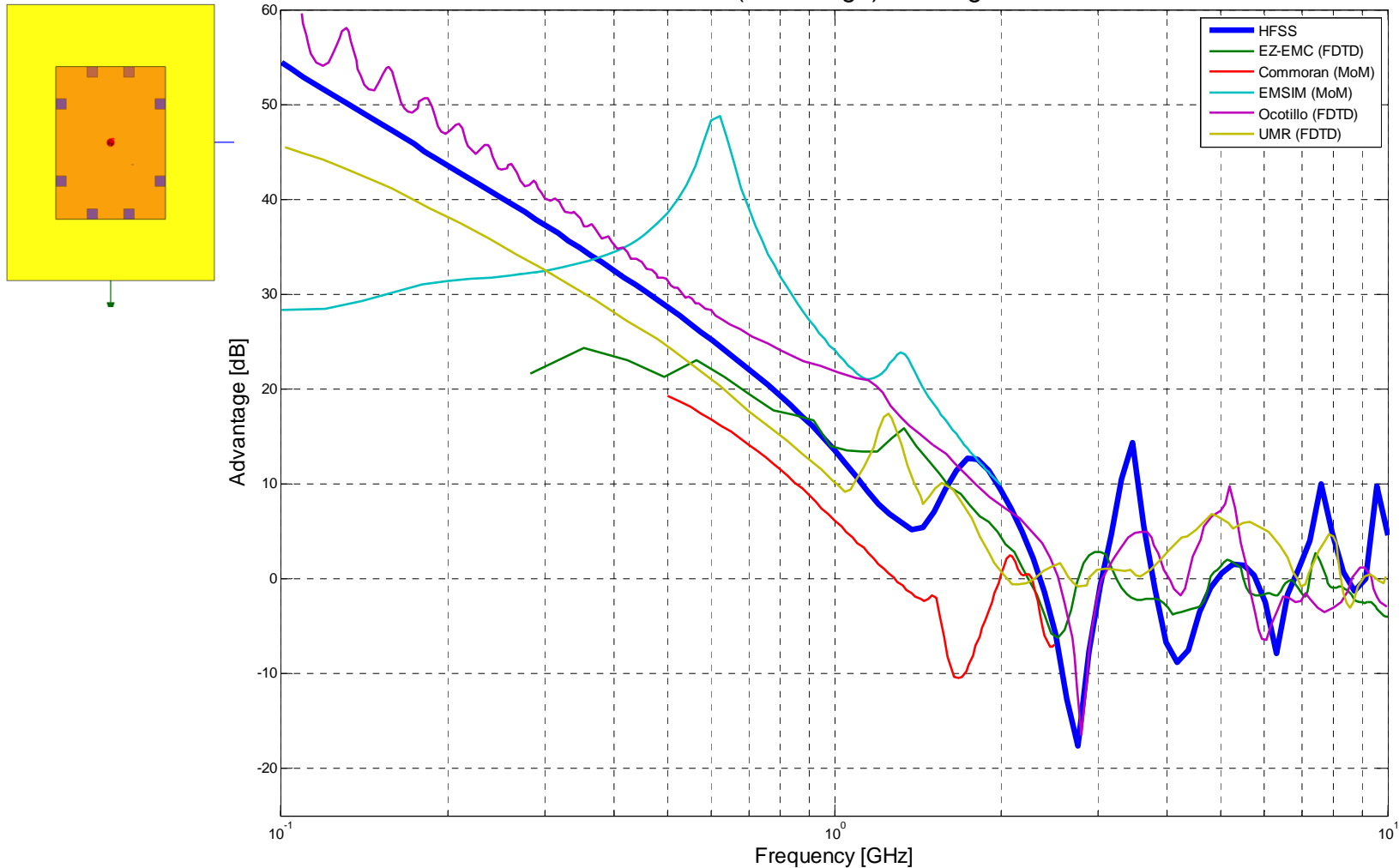

Summary I

- Adding more vias to ground a heatsink improves the EMI performance relating to the frequency content of the emissions.
- More vias pushes out the “cutoff” frequency of the EMI advantage

HFSS performance

- V11 Simulations performed above took ~30 minutes to complete on a Intel Core 2 Duo T7200 (2.0 GHz)
- This includes ~ 2 minutes for adaptive process and ~ 28 minutes to solve 100 discrete points
 - Using Distributed Solve Option, this total simulation time can be reduced to ~ 4 minutes with 10 machines
- The reference paper has this to say about HFSS performance:

Ansoft's HFSS was also used to evaluate this geometry but produced results which were inconsistent with the FDTD and MoM results. Investigation of a broad bandwidth required in containment analysis resulted in long simulation times. Therefore, repeated solutions at every frequency of interest was time prohibitive. This is especially true at higher frequencies where the heat sink becomes electrically large. Further, the resonant nature of the heat sink was not observed using this tool.

HFSS v8.5

- The above problems were created and solved in v8.5 (circa 2002)
- Results were extracted and compared to v11 results
- V8.5 was not capable of extracting the same fields quantities as v11, so some differences are visible in the results
- V8.5 uses Fast Frequency sweeps instead of discrete sweeps

HFSS v8.5 Performance

- Simulations performed on a Intel Xeon Workstation (2.66 GHz)
- ~ 11 minutes to adapt and solve a single fast frequency sweep

The screenshot displays the HFSS v8.5.19 software interface. The main window shows the 'PROFILE INFORMATION' for a simulation named 'heatsink_1_ground'. The profile includes a table of simulation steps, their real and CPU times, memory usage, and the number of elements. The simulation was completed on 08/18/2007 at 23:02:11.

Command/Info	Real Time	CPU Time	Mem Size	Num Elements
Ansoft HFSS Version 8.5.19 beginning heatsink_1_ground on VENETIAN at 08/18/2007 22:50:46				
Lambda Refinement				
wave_1_seed	00:00:10	00:00:10	N/A	10931 tetrahedra
Finished heatsink_1_ground on VENETIAN in 00:00:11 at 08/18/2007 22:50:57				
Ansoft HFSS Version 8.5.19 beginning heatsink_1_ground on VENETIAN at 08/18/2007 22:50:57				
Fast Sweep				
Frequency: 10 GHz, Port Calibration				
port1_solve	00:00:00	00:00:00	OK	2 triangles
port_freq	00:00:01	00:00:00	N/A	10931 tetrahedra
port1_solve	00:00:00	00:00:00	OK	2 triangles
port1_solve	00:00:00	00:00:00	OK	2 triangles
port1_solve	00:00:00	00:00:00	OK	2 triangles
fsweep_part1	00:00:15	00:00:11	N/A	10931 tetrahedra
Solver CSS	00:00:21	00:00:27	N/A	67470 matrix 34221 K
Disk I/O				
reduce_model	00:09:42	00:09:31	N/A	67471 matrix 108140 K
Disk I/O				
fsweep_part2	00:00:36	00:00:36	N/A	10931 tetrahedra
Frequency: 10 GHz, Ports Only Solution				
port1_solve	00:00:00	00:00:00	OK	2 triangles
port_freq	00:00:01	00:00:00	N/A	10931 tetrahedra
Frequency: 1 GHz, Ports Only Solution				
port1_solve	00:00:01	00:00:00	OK	2 triangles
port_freq	00:00:00	00:00:00	N/A	10931 tetrahedra
Frequency: 5.5 GHz, Ports Only Solution				
port1_solve	00:00:00	00:00:00	OK	2 triangles
port_freq	00:00:01	00:00:00	N/A	10931 tetrahedra
Total	00:11:08	00:10:49	OK	10931 tetrahedra
Finished heatsink_1_ground on VENETIAN in 00:11:14 at 08/18/2007 23:02:11				

HFSS – v11 vs. v8.5

1 Ground Via

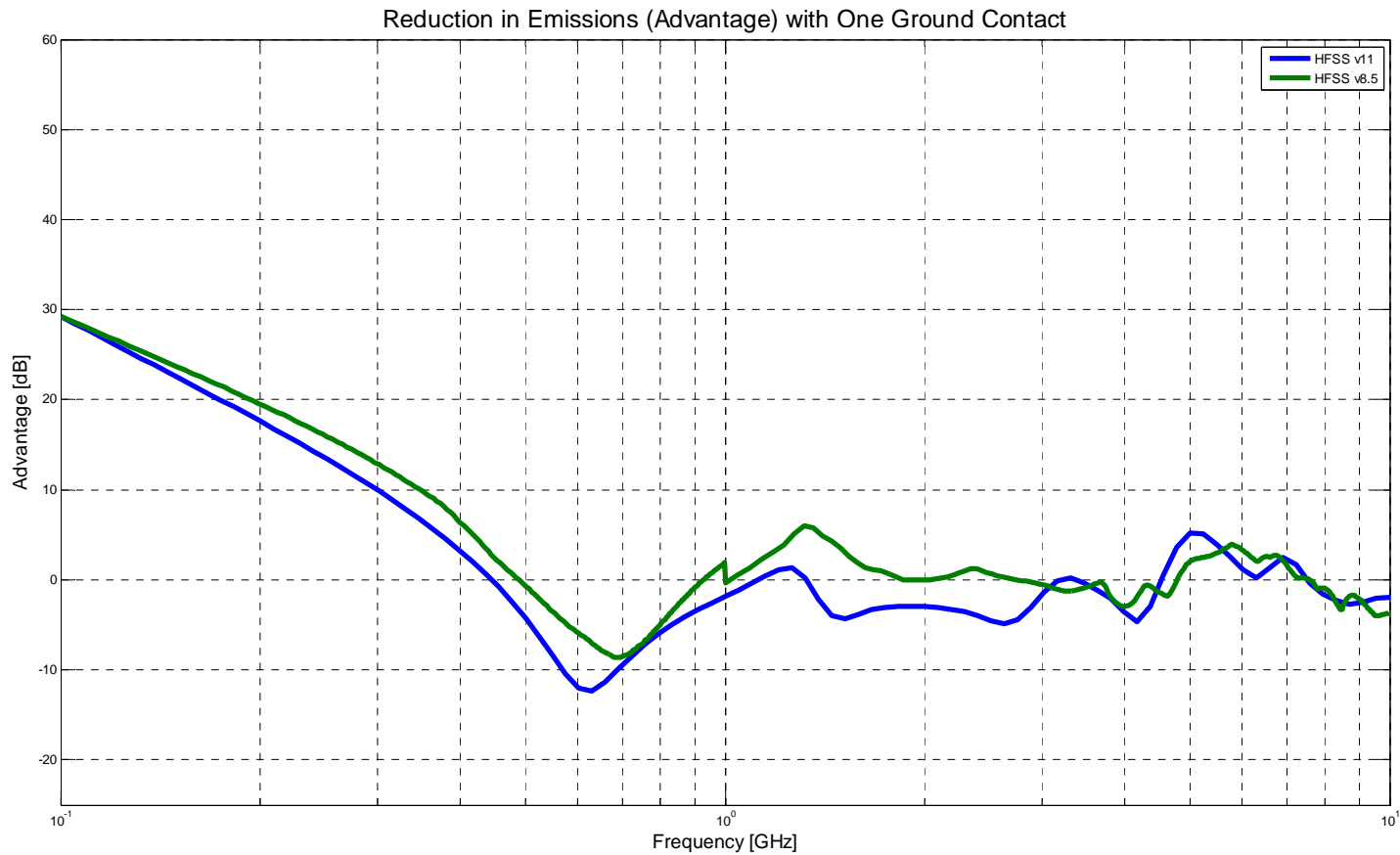

HFSS – v11 vs. v8.5

2 Side Ground Vias

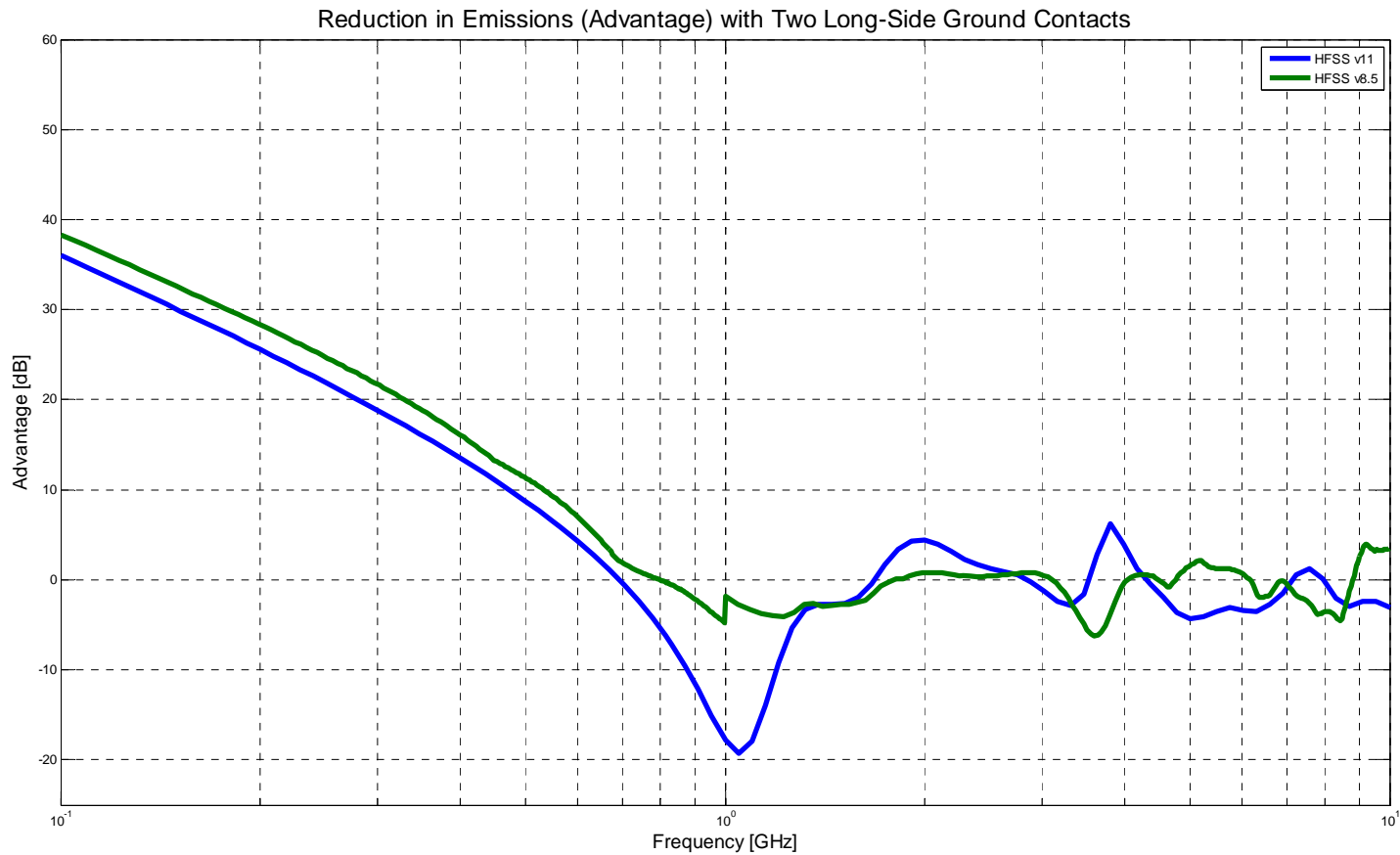

HFSS – v11 vs. v8.5

4 Corner Ground Vias

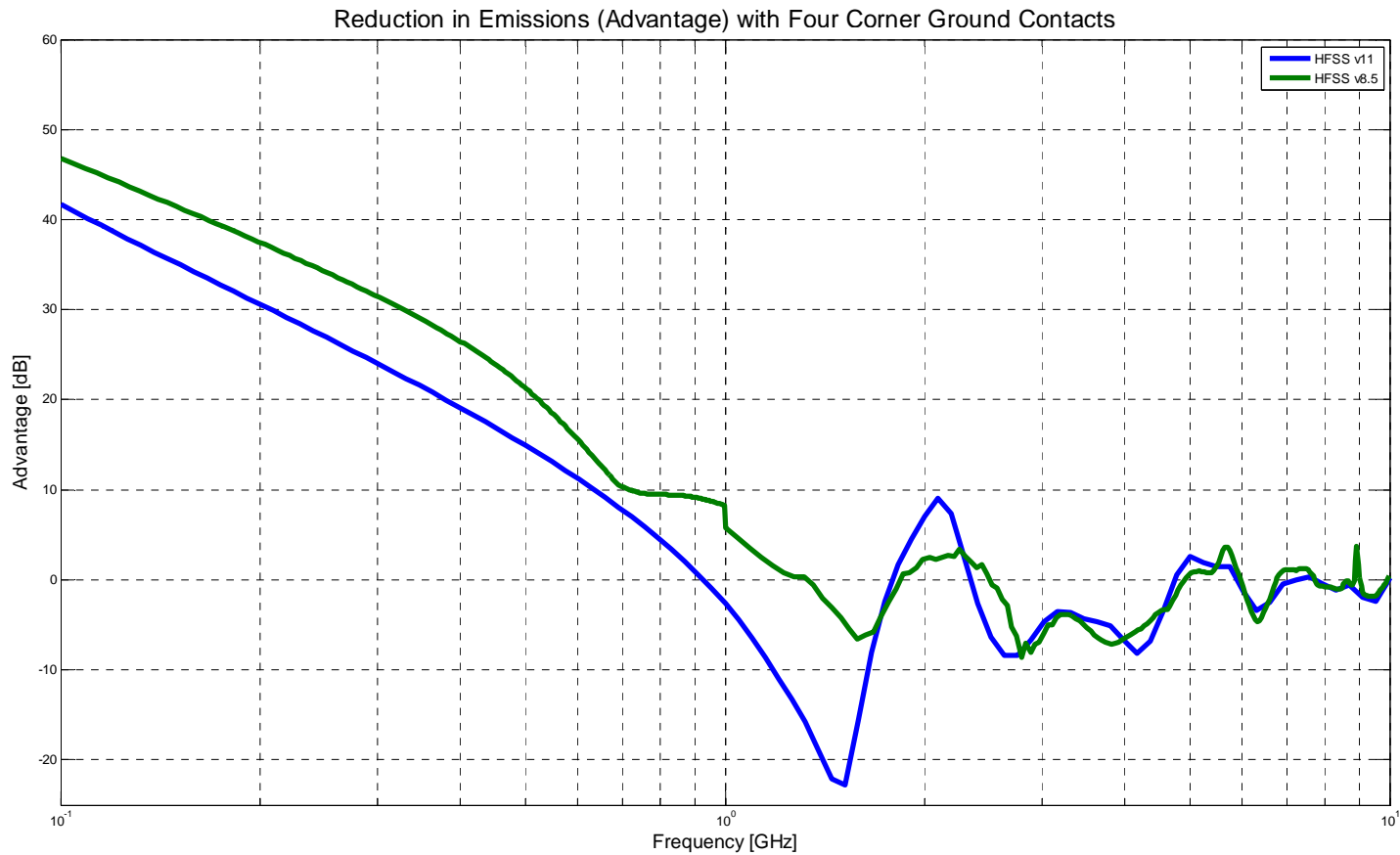

HFSS – v11 vs. v8.5

8 Grounds

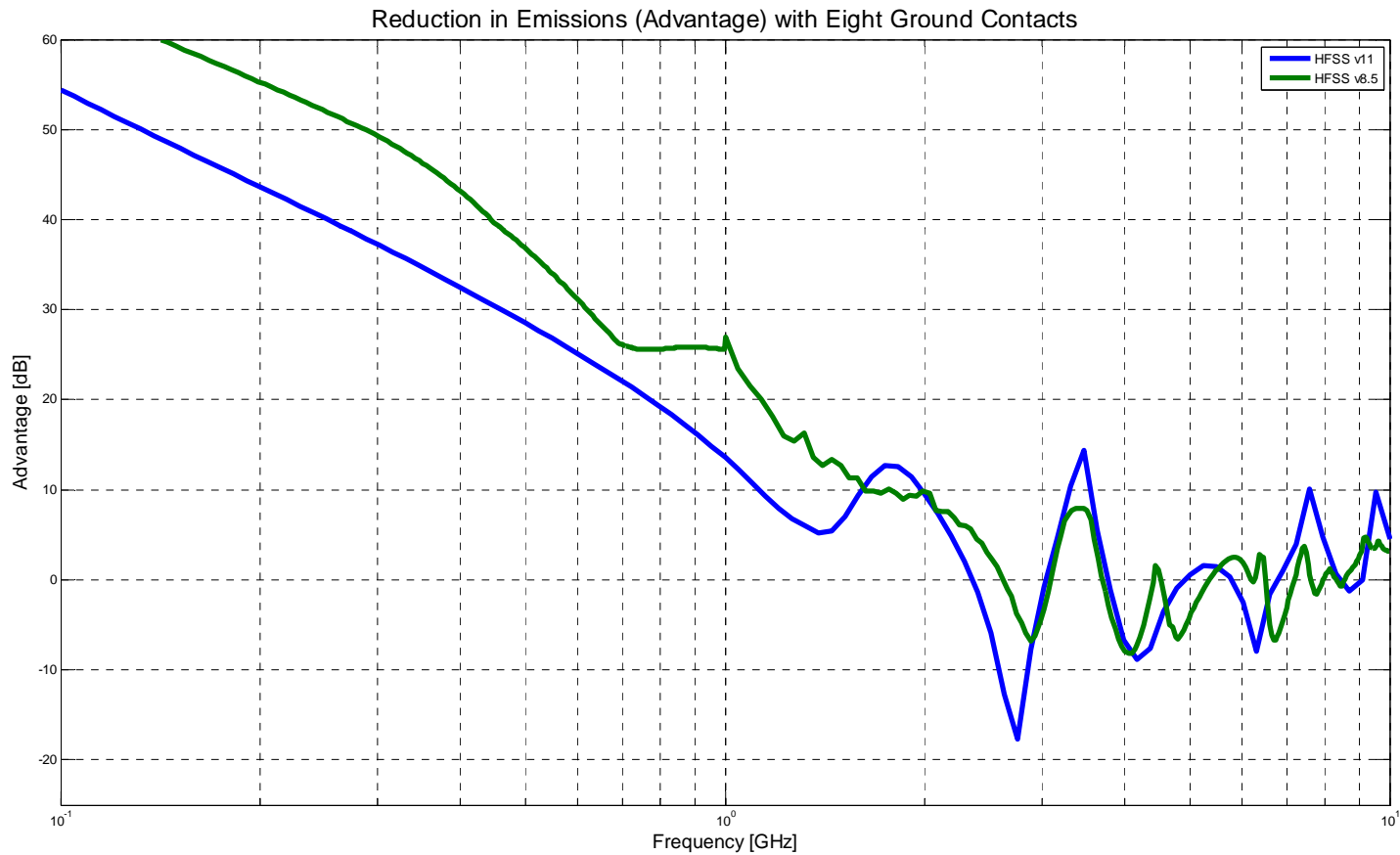

Summary 2

- HFSS v8.5 (circa 2002) delivers similar results to current generation code
- Simulation times are not significantly out of proportion to v11 results

Conclusions

- The standard heatsink problem is a simple one to test the efficacy of the EM solver
- HFSS (v11 & v8.5) predict results similar to codes utilized in reference paper
- HFSS v11 simulated these problems 4x faster, and with 2x less memory than v8.5
- HFSS is an accurate tool for prediction of EMI effects related to insufficient grounding