

# Ansoft Designer™ & NI LabVIEW

Enhancing productivity through  
EDA and T&M interoperability

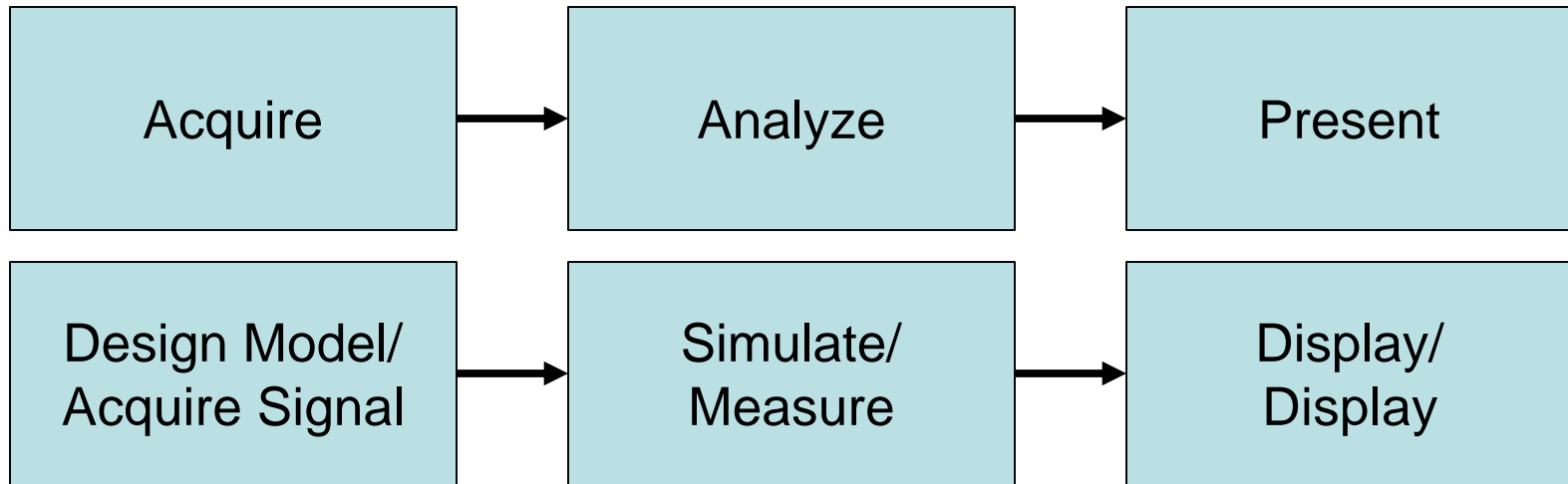

# Engineering Methodology



- 1600 Instrument Drivers
- PXI Connectivity
- Serial, GPIB, VXI, USB interfacing

- DSP Tools
- Statistical
- Curve Fitting
- Wavelets

- Custom Visualization
- WebServers
- Report Generation
- Database Storage



# Instrumentation Neutrality

**NI LabVIEW offers a  
wide range of instrumentation**

- Over 1300 drivers available for LV
- Open code for further driver development and customization



# Simulation & Measurement in the Product Development Flow

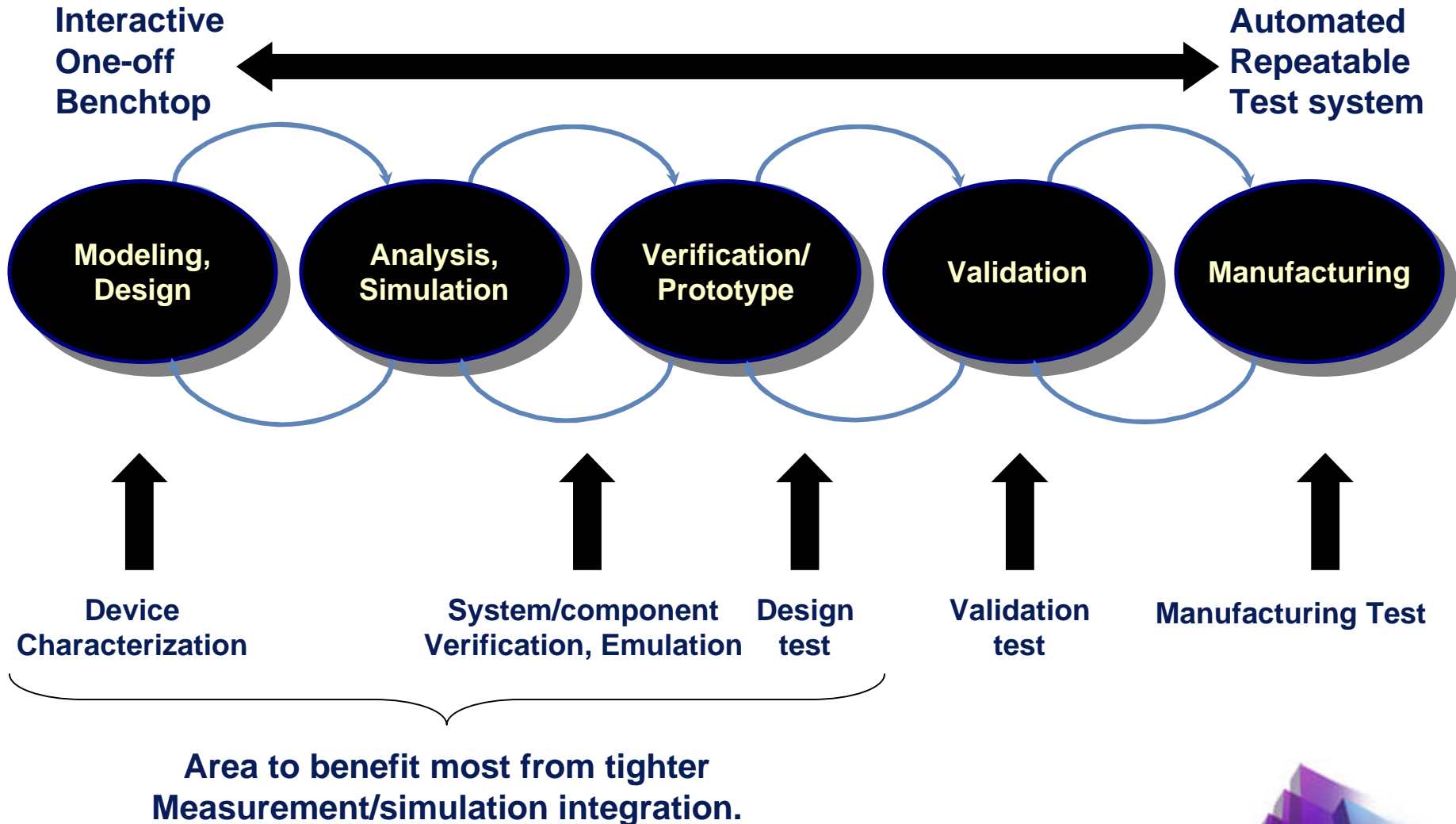

# Simulation and Measurement in the Design Cycle

Design Entry	Simulate	Post-process	Optimize
Fixturing and calibration	Measure	Display	Tweak

- Both have similar methodologies for design/component characterization
- Reliable simulation needs accurate electrical models and simulation technology
- Reliable measurement needs accurate test equipment and system calibration.



# Proposal:

**Provide customers with tighter integration between simulation software and measurement equipment for greater productivity & design reliability.**



# Challenges & Solutions

## Challenge

- ▶ Optimize Data exchange between simulation and Measurement for enhanced productivity

## Issues

- ▶ Software packages run independently
- ▶ Data exchange formats must be compatible
- ▶ Large number of test equipment to support, limitless test systems possible

## Solution

- ▶ The Measurement Model – Ansoft Designer connected to National Instruments LabVIEW



# “Test Instrumentation” Within the Virtual Design Environment

UDM's link NI's LabVIEW and Ansoft Designer

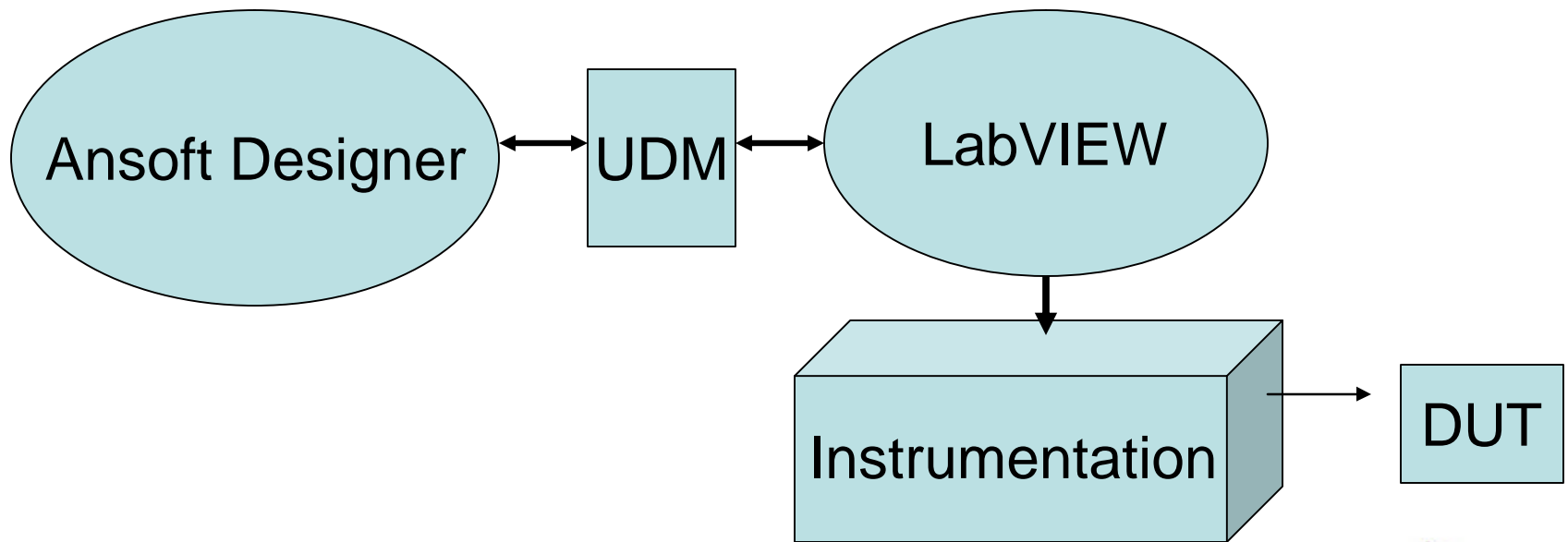

Labview's "Virtual Instruments" linked to Ansoft Designer, combines two environment rather than a single piece of test equipment. This allows more measurement flexibility.

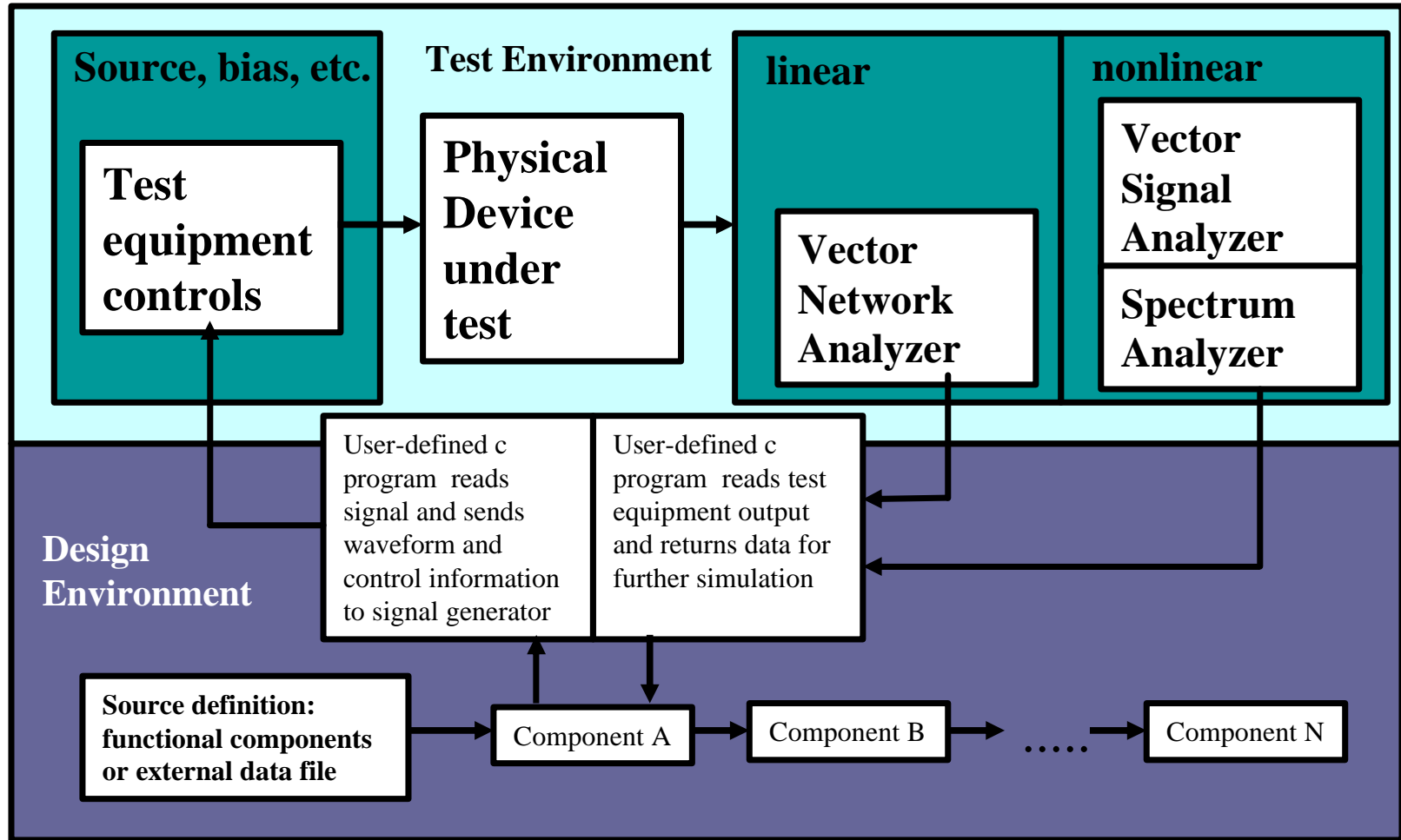

# Applications for the Measurement Model

- ▶ **Parametric Extraction**
- ▶ **Add-on Analysis**
- ▶ **Sanity Checking**
- ▶ **Active Modeling**



# Example 1: Modeling a Transistor

**This demonstration utilizes Ansoft Designer's UDM capability to capture S-parameter data from a Vector Network Analyzer**

**Compare data to the raw simulation data of the packaged component: a Sirenza SHF-0289, GaAs HFET transistor.**



# Customer requires bias dependent S-parameters of packaged discrete transistor for use in Design.

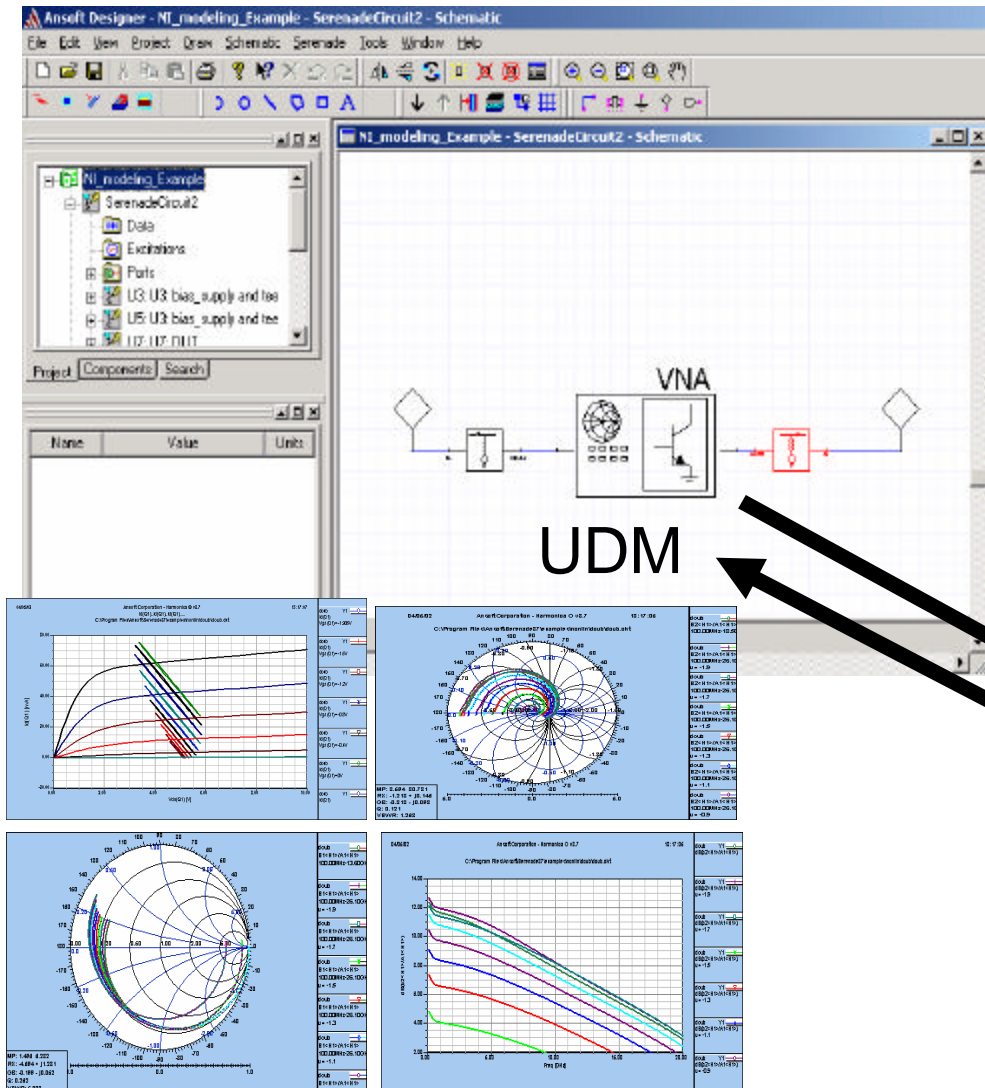

UDM

Set bias

Set freq sweep

Perform VNA meas.

Return data

LabVIEW



# Example 1: Modeling a Transistor

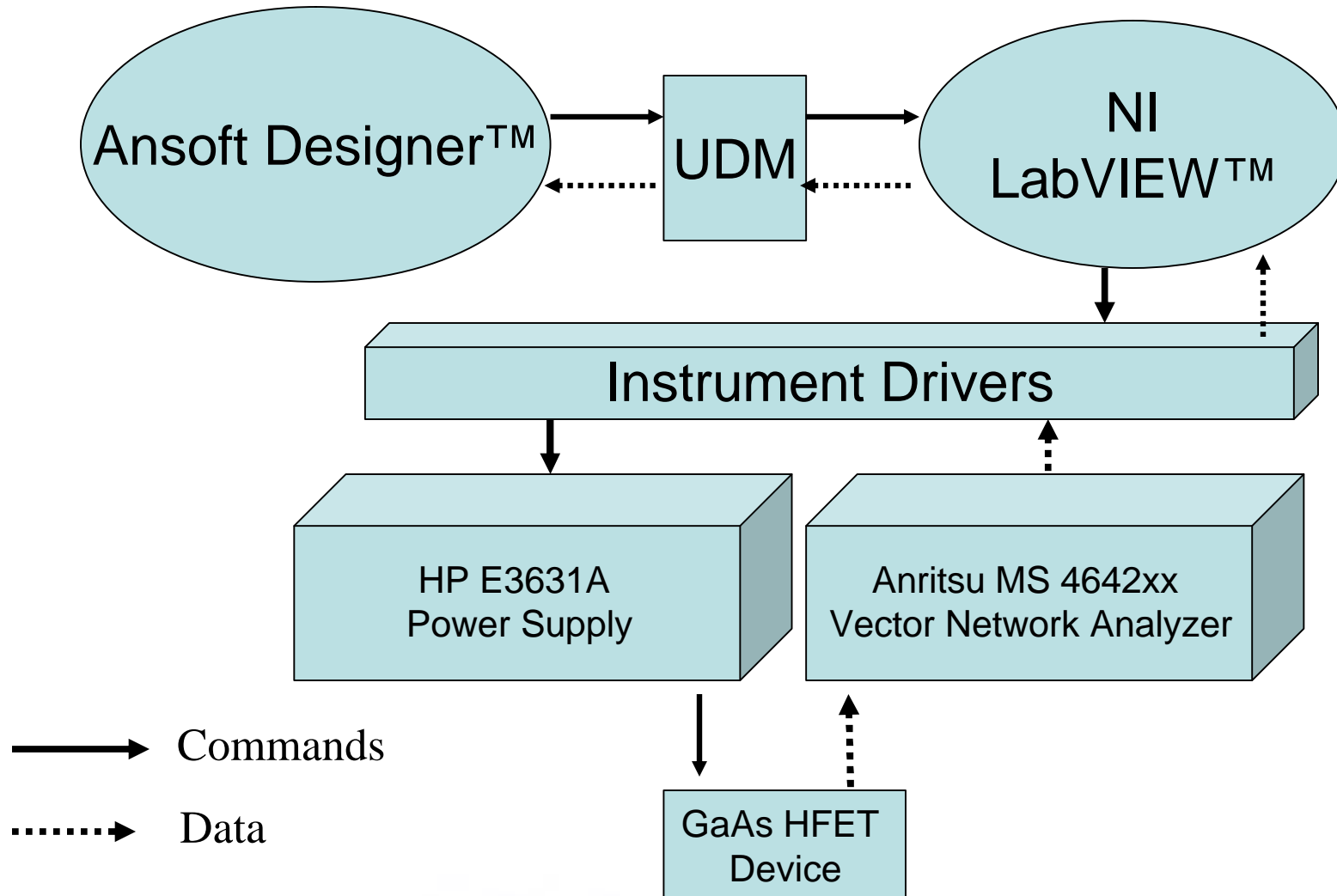

# Example 2: Testing RF Sub-System

**Invokes Ansoft Designer to model a single upconversion stage sub-system consisting of a Mixer, Amplifier, and Oscillator.**

**The sub-system takes an IF signal of 10 - 20 MHz range and up-converts it to 310-320 MHz.**

**In the demonstration we measure Adjacent Channel Power (ACPR) and Spur Charts**



# Example 2: Demo

————> Commands  
.....> Data

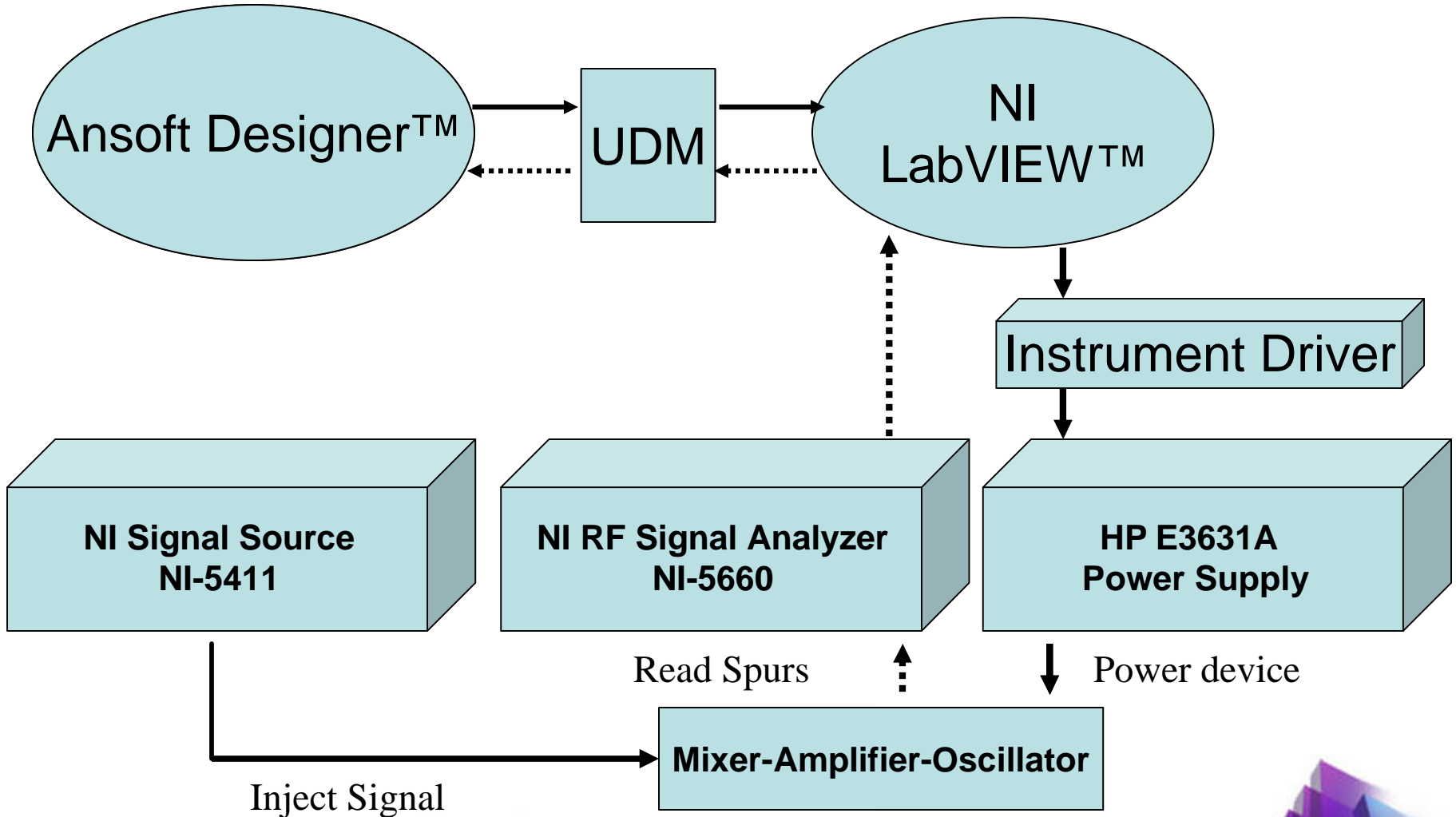

# Ansoft/NI Value Proposition to Designers

**Virtual instrumentation makes your design flow more efficient by:**

- ▶ Making it easy to take real-world measurements
- ▶ Interfacing seamlessly with common design tools



# Thank You

