

Ansoft Simplorer for functionally proven
integrated circuit architectures

Ansoft Simplorer for functionally proven integrated circuit architectures



Abstract

Traditional SPICE like simulators tend to have difficulty in simulating complex power electronic circuits. With more and more complex power management products on the horizon, there is a need for a better simulator. Ansoft Simplorer solves the convergence issue and presents as a multi-domain simulator for power management system level evaluation. Its block diagram, state graph, equation, C-dll along with rich libraries make powerful behavior simulation easy. In this presentation we talk about extending Simplorer's capability into verifying circuits designed by other software packages such as Verilog simulator VCS/NCSim and SPICE. The extension follows a path of IC behavior definition by Simplorer simulation of targeted applications and Simplorer co-simulating with IC designing tools.

Behavior system simulation for application scenarios to meeting product specs

Product specs define application scenarios from which simulation schematics are created.

The screenshot shows the SSC 7.0 Commander software interface. The main window displays a list of simulation scripts with columns for File name, File path, and Last change. The file names follow a naming convention: `sd0_V[component]_LED[part number]_I[part number]_L[part number]_C[part number].ssh`. The last change column shows dates and times, with the most recent being 11/02/05 22:04:29.

File name	File path	Last change
sd0_V55_LED6_I20_0147_L816_C3.ssh	\\Dong_desktop\office\Year06\Exclara\Simulations\sd0\simulations	05.04.05 21:24:27
sd0_V55_LED6_I20_0100_L544_C1.ssh	\\Dong_desktop\office\Year06\Exclara\Simulations\sd0\simulations	05.04.05 21:23:04
sd0_V55_LED6_I20_0125_L68_C2.ssh	\\Dong_desktop\office\Year06\Exclara\Simulations\sd0\simulations	05.04.05 21:21:44
sd0_V25_LED6_I5_0125_L68_C2.ssh	\\Dong_desktop\office\Year06\Exclara\Simulations\sd0\simulations	05.04.05 21:20:24
sd0_V25_LED6_I10_0125_L68_C2.ssh	\\Dong_desktop\office\Year06\Exclara\Simulations\sd0\simulations	05.04.05 21:19:10
sd0_V25_LED6_I20_0147_L816_C3.ssh	\\Dong_desktop\office\Year06\Exclara\Simulations\sd0\simulations	05.04.05 21:17:56
sd0_V25_LED6_I20_0100_L544_C1.ssh	\\Dong_desktop\office\Year06\Exclara\Simulations\sd0\simulations	05.04.05 21:16:39
sd0_V25_LED6_I20_0125_L68_C2.ssh	\\Dong_desktop\office\Year06\Exclara\Simulations\sd0\simulations	05.04.05 21:15:24
sd0_V55_LED4_I5_0125_L68_C2.ssh	\\Dong_desktop\office\Year06\Exclara\Simulations\sd0\simulations	05.04.05 21:14:08
sd0_V55_LED4_I15_0125_L68_C2.ssh	\\Dong_desktop\office\Year06\Exclara\Simulations\sd0\simulations	05.04.05 21:12:54
sd0_V55_LED4_I30_0147_L816_C3.ssh	\\Dong_desktop\office\Year06\Exclara\Simulations\sd0\simulations	05.04.05 21:11:36
sd0_V33_LED4_I30_0125_L68_C2.ssh	\\Dong_desktop\office\Year06\Exclara\Simulations\sd0\simulations	05.04.05 21:10:20
sd0_V33_LED4_I5_0125_L68_C2.ssh	\\Dong_desktop\office\Year06\Exclara\Simulations\sd0\simulations	05.04.05 21:09:02
sd0_V33_LED4_I15_0125_L68_C2.ssh	\\Dong_desktop\office\Year06\Exclara\Simulations\sd0\simulations	05.04.05 21:07:44
sd0_V33_LED4_I30_0147_L816_C3.ssh	\\Dong_desktop\office\Year06\Exclara\Simulations\sd0\simulations	05.04.05 21:06:25
sd0_V33_LED4_I30_0125_L68_C2.ssh	\\Dong_desktop\office\Year06\Exclara\Simulations\sd0\simulations	05.04.05 21:05:08
sd0_V25_LED4_I30_0125_L544_C1.ssh	\\Dong_desktop\office\Year06\Exclara\Simulations\sd0\simulations	05.04.05 21:03:45
sd0_V25_LED4_I30_0100_L544_C1.ssh	\\Dong_desktop\office\Year06\Exclara\Simulations\sd0\simulations	05.04.05 21:01:47
sd0_V33_LED4_I30_0100_L544_C1.ssh	\\Dong_desktop\office\Year06\Exclara\Simulations\sd0\simulations	05.04.05 20:59:24
sd0_V33_LED4_I30_0125_L68_C2.ssh	\\Dong_desktop\office\Year06\Exclara\Simulations\sd0\simulations	05.04.05 20:58:08
sd0_V25_LED4_I5_0125_L68_C2.ssh	\\Dong_desktop\office\Year06\Exclara\Simulations\sd0\simulations	05.04.05 20:56:43
sd0_V25_LED4_I15_0125_L68_C2.ssh	\\Dong_desktop\office\Year06\Exclara\Simulations\sd0\simulations	05.04.05 20:55:17
sd0_V25_LED4_I30_0125_L816_C3.ssh	\\Dong_desktop\office\Year06\Exclara\Simulations\sd0\simulations	05.04.05 20:53:23
sd0_V25_LED4_I30_0147_L816_C3.ssh	\\Dong_desktop\office\Year06\Exclara\Simulations\sd0\simulations	05.04.05 20:51:53
sd0_V25_LED4_I30_0125_L68_C2_Short.ssh	\\Dong_desktop\office\Year06\Exclara\Simulations\sd0\simulations	05.04.05 20:50:21
sd0_V25_LED4_I30_0125_L68_C2_OT.ssh	\\Dong_desktop\office\Year06\Exclara\Simulations\sd0\simulations	05.04.05 20:48:49
sd0_V55_LED2_I5_0147_L376_C8_ShortV1.ssh	\\Dong_desktop\office\Year06\Exclara\Simulations\sd0\simulations	05.04.05 18:29:57
sd0_V55_LED2_I5_0147_L376_C8_OT.ssh	\\Dong_desktop\office\Year06\Exclara\Simulations\sd0\simulations	05.04.05 18:28:33
sd0_V25_55_LED2_I5_0147_L376_C8.ssh	\\Dong_desktop\office\Year06\Exclara\Simulations\sd0\simulations	05.04.05 18:27:13
sd0_V55_LED2_I5_0147_L376_C8_FB.ssh	\\Dong_desktop\office\Year06\Exclara\Simulations\sd0\simulations	05.04.05 18:25:47
sd0_V55_LED2_I5_0147_L376_C8_FB.ssh	\\Dong_desktop\office\Year06\Exclara\Simulations\sd0\simulations	05.04.05 18:24:20
sd0_V55_LED2_I5_0147_L376_C8_D4K.ssh	\\Dong_desktop\office\Year06\Exclara\Simulations\sd0\simulations	05.04.05 18:24:10
sd0_V25_LED8_I15_0100_L816_C3.ssh	\\Dong_desktop\office\Year06\Exclara\Simulations\sd0\simulations	05.04.05 18:21:10
sd0_V55_LED2_I5_0147_L376_C8_OV.ssh	\\Dong_desktop\office\Year06\Exclara\Simulations\sd0\simulations	05.04.05 18:19:41
sd0_V25_LED4_I30_0125_L68_C2_OV.ssh	\\Dong_desktop\office\Year06\Exclara\Simulations\sd0\simulations	05.04.05 18:04:46
sd0_V25_LED4_I30_0125_L68_C2_ShortV1.ssh	\\Dong_desktop\office\Year06\Exclara\Simulations\sd0\simulations	05.04.05 18:02:07
sd0_V25_LED8_I15_0100_L816_C3_ShortV1.ssh	\\Dong_desktop\office\Year06\Exclara\Simulations\sd0\simulations	05.04.05 17:59:20
sd0_V25_LED8_I15_0100_L816_C3_OV.ssh	\\Dong_desktop\office\Year06\Exclara\Simulations\sd0\simulations	05.04.05 17:55:53
sd0_V25_LED8_I15_0100_L816_C3_OT.ssh	\\Dong_desktop\office\Year06\Exclara\Simulations\sd0\simulations	05.04.05 17:52:59
sd0_V25_55_LED4_I30_0125_L68_C2.ssh	\\Dong_desktop\office\Year06\Exclara\Simulations\sd0\simulations	05.04.05 17:50:38
sd0_V25_55_LED8_I15_0100_L816_C3.ssh	\\Dong_desktop\office\Year06\Exclara\Simulations\sd0\simulations	05.04.05 17:48:47
sd0_V25_LED4_3_2_I30_0125_L68_C2.ssh	\\Dong_desktop\office\Year06\Exclara\Simulations\sd0\simulations	05.04.05 17:45:38
sd0_V25_LED8_7_6_I15_0100_L816_C3.ssh	\\Dong_desktop\office\Year06\Exclara\Simulations\sd0\simulations	05.04.05 10:35:37
sd0_V25_LED4_I30_0125_L68_C2_D4K.ssh	\\Dong_desktop\office\Year06\Exclara\Simulations\sd0\simulations	05.04.05 10:33:34
sd0_V25_LED8_I15_0100_L816_C3_FB.ssh	\\Dong_desktop\office\Year06\Exclara\Simulations\sd0\simulations	05.04.05 10:31:47
sd0_V25_LED4_I30_0125_L68_C2_FB.ssh	\\Dong_desktop\office\Year06\Exclara\Simulations\sd0\simulations	05.04.05 10:30:01
sd0_V55_LED6_I5_0125_L68_C2.ssh	\\Dong_desktop\office\Year06\Exclara\Simulations\sd0\simulations	05.04.05 10:28:09
sd0_V25_LED4_I30_0125_L68_C2.ssh	\\Dong_desktop\office\Year06\Exclara\Simulations\sd0\simulations	05.04.05 10:26:31
sd0_V25_LED8_I15_0100_L816_C3_D4K.ssh	\\Dong_desktop\office\Year06\Exclara\Simulations\sd0\simulations	05.04.05 10:21:06
sd0_V55_LED2_I5_0147_L376_C8.ssh	\\Dong_desktop\office\Year06\Exclara\Simulations\sd0\simulations	05.04.05 10:16:58
sd0_V55_LED2_I5_0147_L376_C8.ssh	\\Dong_desktop\office\Year06\Exclara\Simulations\sd0\simulations	11/02/05 22:04:29

Queue

Simulation Script	Path	Status	Sender	Receiver
-------------------	------	--------	--------	----------

Ready

A zoom into one schematic

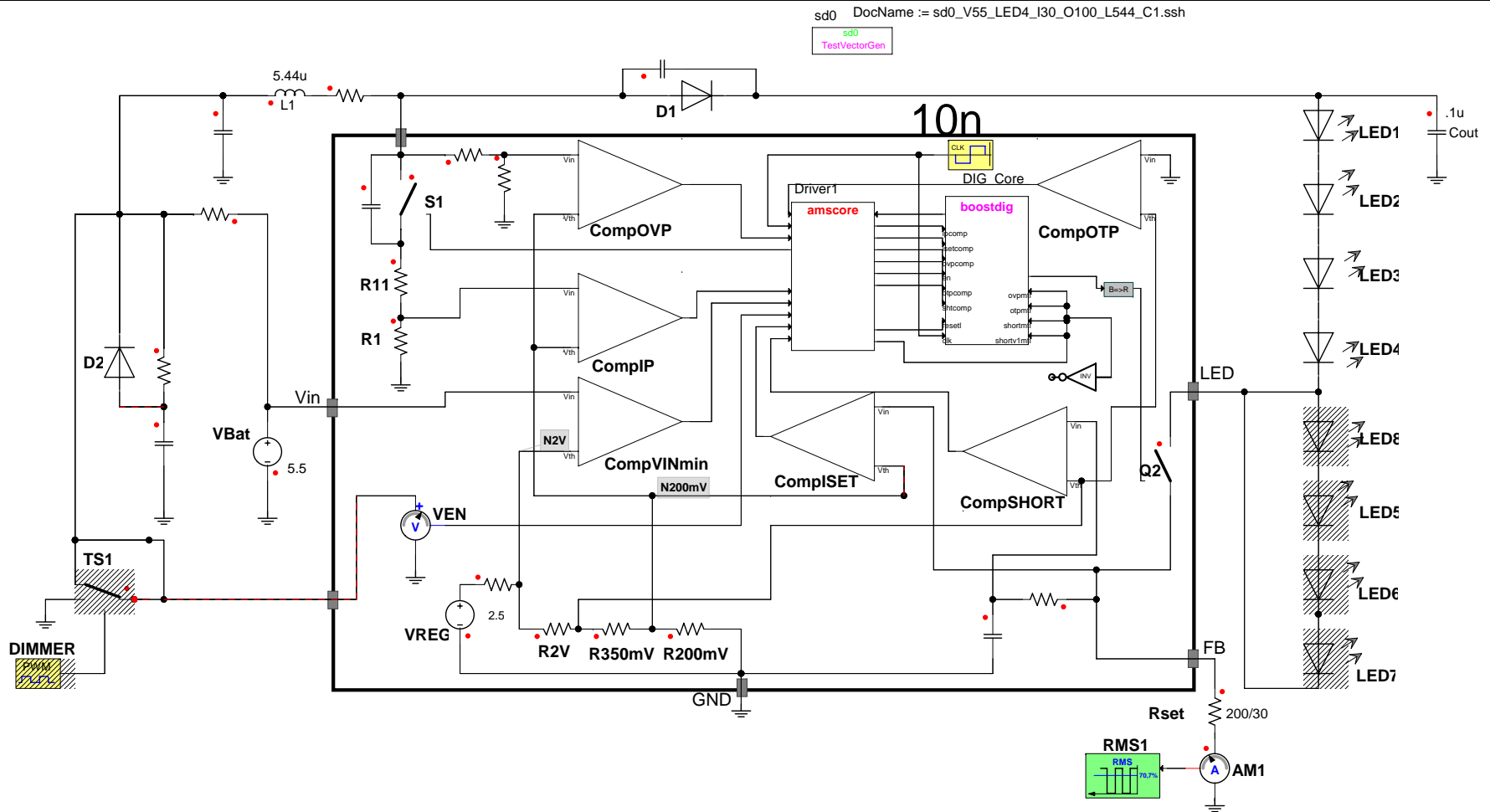

- Behavior simulation is the way for qualifying analog-digital mixed signal technology for power management IC – sim speed, all corners;
- Lab work becomes sanity check.

Ansoft Simplorer Features



- .Multi-simulator engines – analog, digital (VHDL, VHDL-AMS), block diagram, state machine, equation (math and Boolean operation), measurement;**
- .Multi-domains – electrical, frequency, magnetic, thermal, mechanical, fluidic;**
- .interface to finite element program;**
- .extensive power electronic libraries;**
- .C interface.**

Way to develop innovative technology for power management products with Simplorer:

- 1. Construct power topology in Simplorer schematic;**
- 2. Concept proving with:**
 - 1. VHDL (AMS) or;**
 - 2. Block diagram or;**
 - 3. State machine or;**
 - 4. C-dll.**
- 3. Further verify the technology by**
 - 1. Expand circuit components with parasitic;**
 - 2. Expand to multiple schematics for application scenarios;**
 - 3. Necessary correction with lab data.**

How to bridge the gap between behavior simulation in Simplorer and actual IC design?



Today's Solution

- ❑ Derive individual block specs and hope that the entire Silicon works.

Our Solution – Proprietary extension to co-simulation capability of Simplorer

- ❑ Capability to co-sim Simplorer with industrial strength digital simulators Modeltech Modelsim, Synopsys VCS and Cadence NCSim;
- ❑ Ability to co-sim with SPICE simulation engine.

- ❑ Above two provide us capability to verify analog and digital IC designs on power supply application level.

Thank you

 EXCLARA