

Innovative Transformers and Resonant Inductors and Capacitors

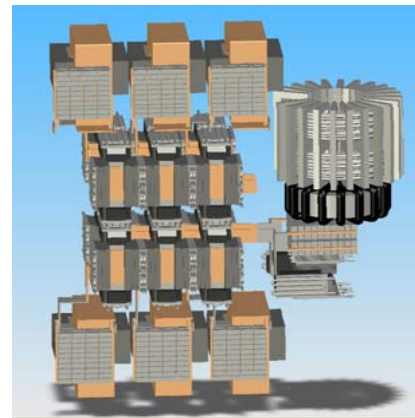
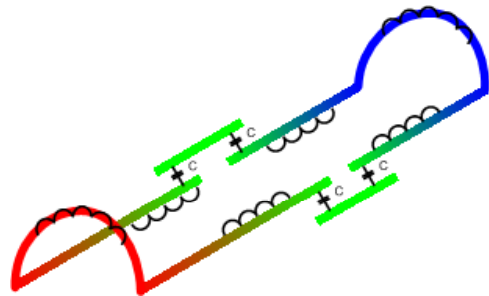

David Cope, Ph.D.

© 2007 Engineering Matters[®], Inc.

www.engineeringmatters.com

Engineering Matters[®]

Short Form Resume

- Incorporated 1998
- Primary Offices in Newton, MA, USA
- Woman-Owned Small Business
- Experts in Electromagnetics and Electromechanics
 - Specialty motors and actuators, power electronics, robotics, electromagnetic signature control and analysis

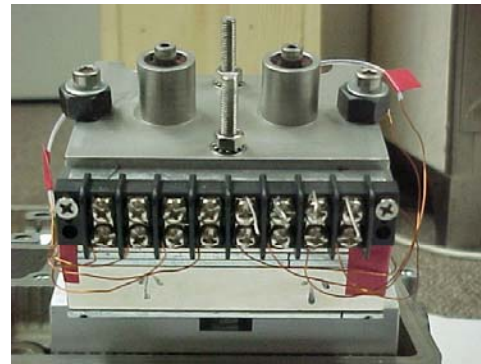
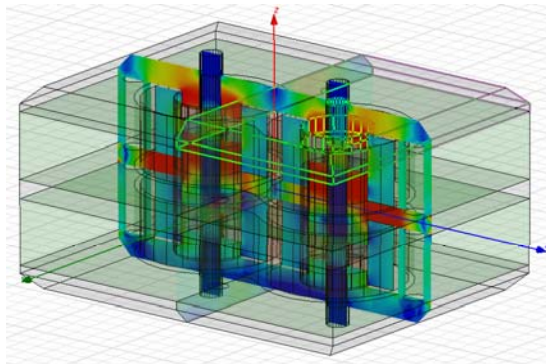

Engineering Matters' *In-house Expertise*

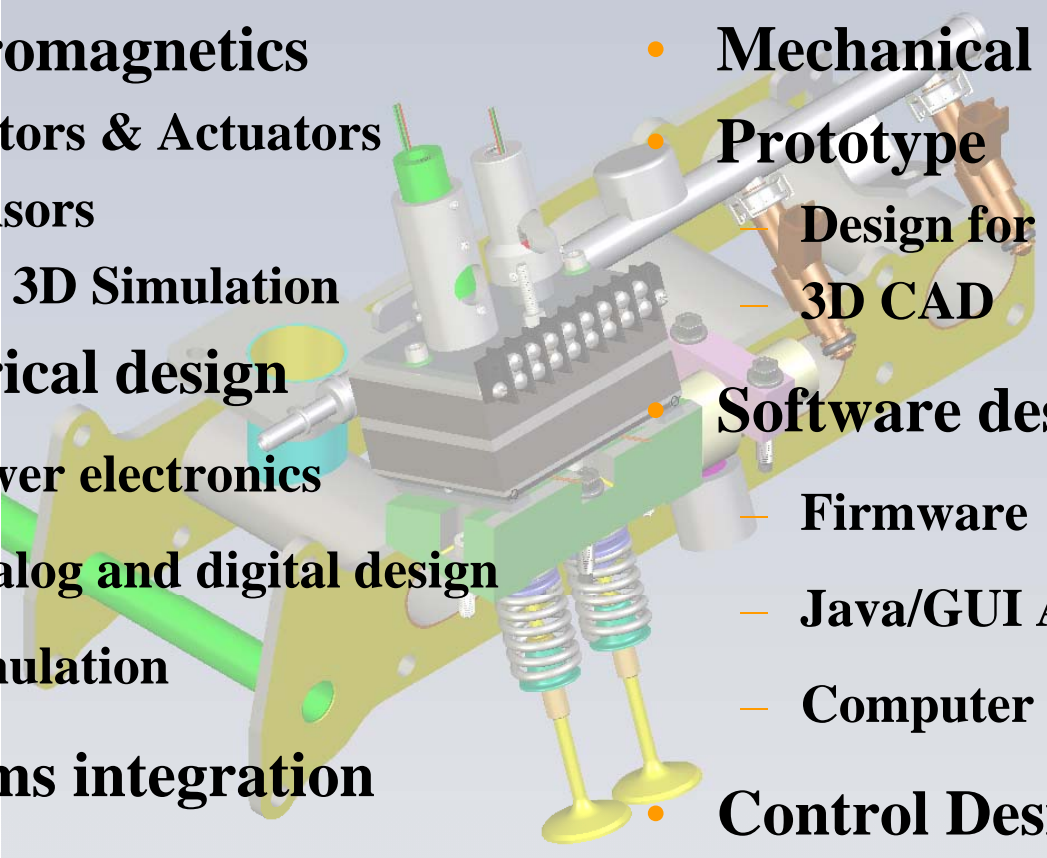
- 
- **Electromagnetics**
 - Motors & Actuators
 - Sensors
 - 2D, 3D Simulation
 - **Electrical design**
 - Power electronics
 - Analog and digital design
 - Simulation
 - **Systems integration**
 - **Mechanical design**
 - **Prototype**
 - Design for Manufacturing
 - 3D CAD
 - **Software design**
 - Firmware
 - Java/GUI API
 - Computer interfacing
 - **Control Design**

Innovative Transformers and Resonant Inductors and Capacitors



- MRI Compatible Stents
 - Images within existing stents are distorted by field perturbations of the stent itself.
 - Develop/determine stent coatings to enable internal imaging.
- Lightweight Transformer
 - More Electric Ship initiative requires power conditioning equipment.
 - Lightweight, small transformers desired for shipboard power electronics applications.

Stent Project Goals

- Problem: Electrically conductive stents have induced eddy currents which obscure an MRI image.
- Solution: Apply post-manufacturing processes to correct magnetic fields.
- Maxwell critical in comparing configurations and determining component values.

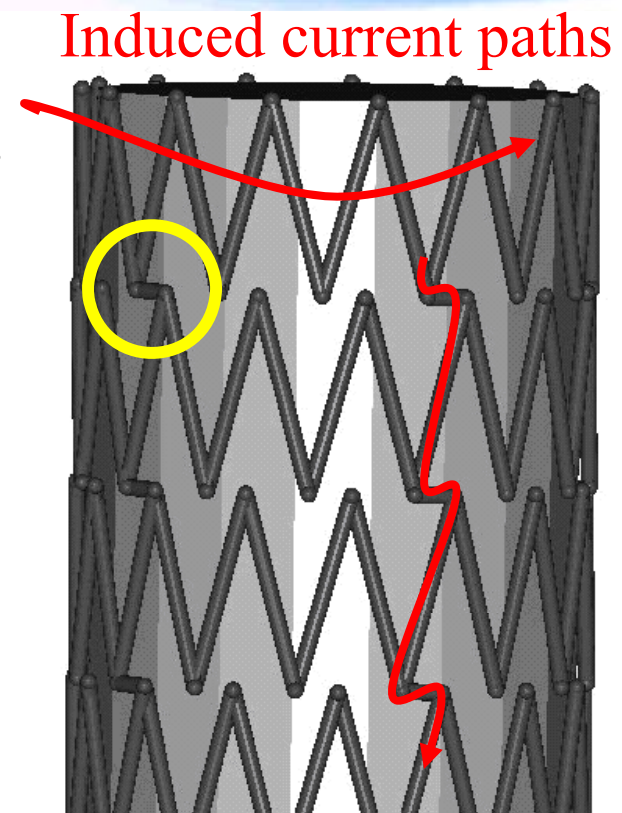

Stent Project Objectives



- Develop a simple physical model of a stent.
- Develop equivalent circuit models including RF, stent, and coatings.
- Develop implementations of distributed magnetic and electric elements to phase shift currents.
- Correct the stent internal field perturbations.

Stent imaging in MRI

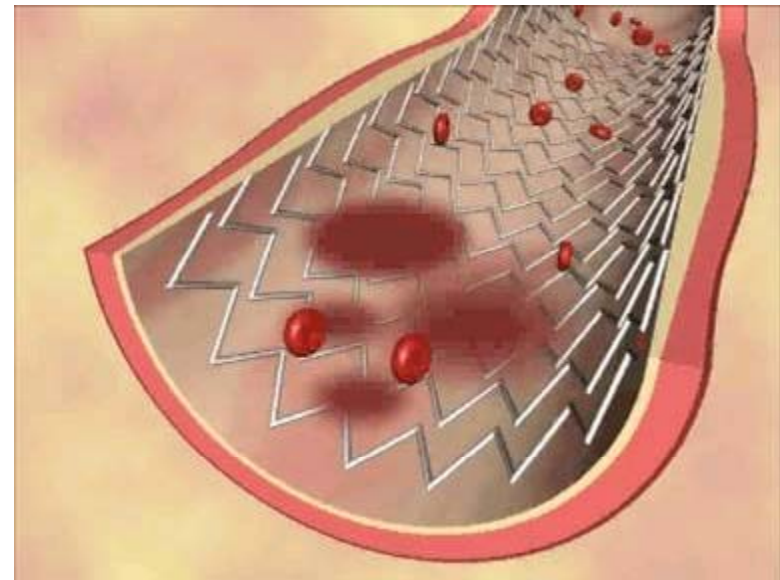
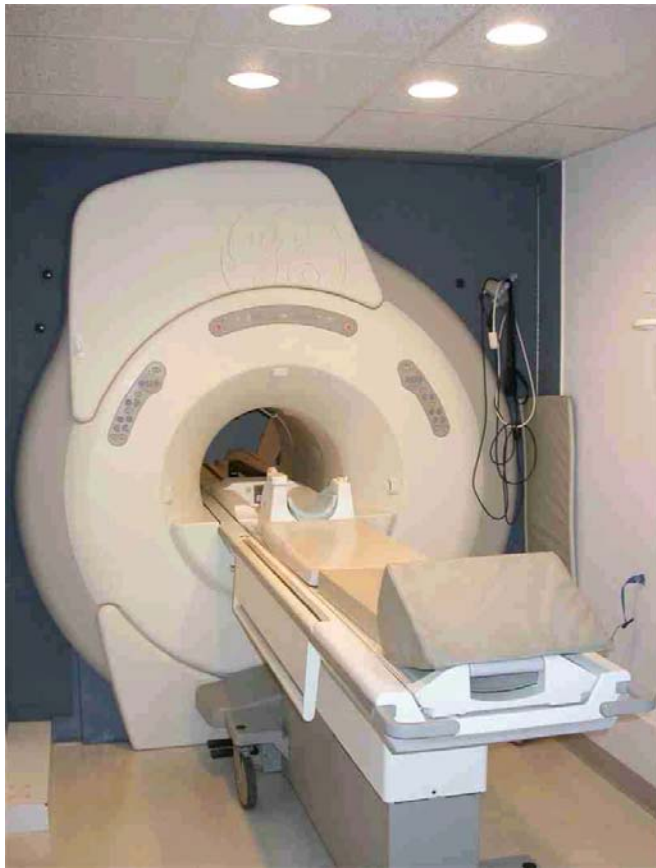

MRI RF (64MHz) Field

- Main field = 1.5T
- $f = 1.5T * 42.576 \text{ MHz/T} = 63.8\text{MHz}$.
- RF Field: $\mathbf{H} = H_x \mathbf{x} + H_y \mathbf{y} + H_z \mathbf{z}$, $|\mathbf{H}| \sim 24\text{A/m}$, $B \sim 30\mu\text{T}$
- Induced RF stent currents: $\mathbf{J} = J_\theta \boldsymbol{\theta} + J_z \mathbf{z}$.
- Skin Depth: The skin depth is defined as: $\delta = \sqrt{\eta/\pi\mu f}$.
- Nitinol skin depth is $\delta = 0.06\text{mm}$; RF fully penetrates each strut.
- Blood solution ($\eta=0.2 \text{ Ohm-m}$), the skin depth is $\delta = 28\text{mm}$. So blood does shield the RF field and body size makes a difference.

MRI-induced current paths

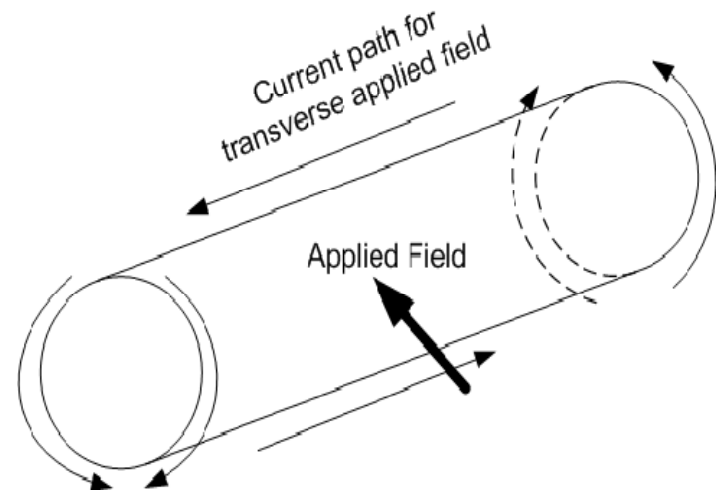
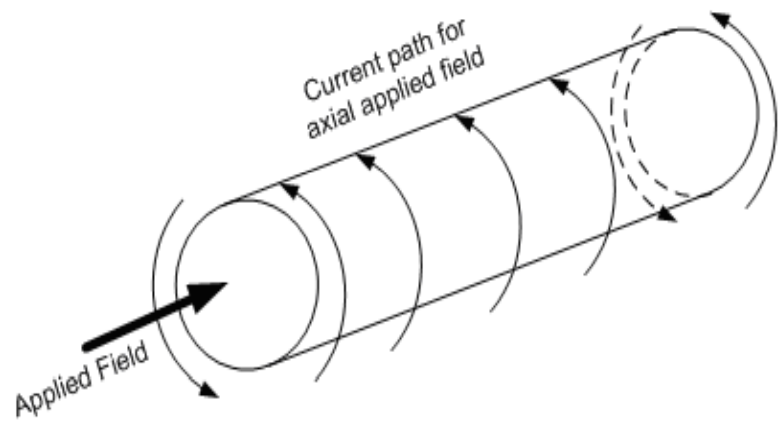

Intuition Needed



- Basic idea: Create a structure which will correct the magnetic field from the stent itself.

Ansoft Maxwell 3D®



- Maxwell's eddy current (harmonic) solution computes a full-wave solution that includes electromagnetic wave radiation effects, i.e. displacement currents.
- Calculates distributed resistive, inductive and capacitive effects.
- $\nabla \times E = -\frac{\partial B}{\partial t}$ $\nabla \times H = J + \frac{\partial D}{\partial t}$

Calculation Flowchart

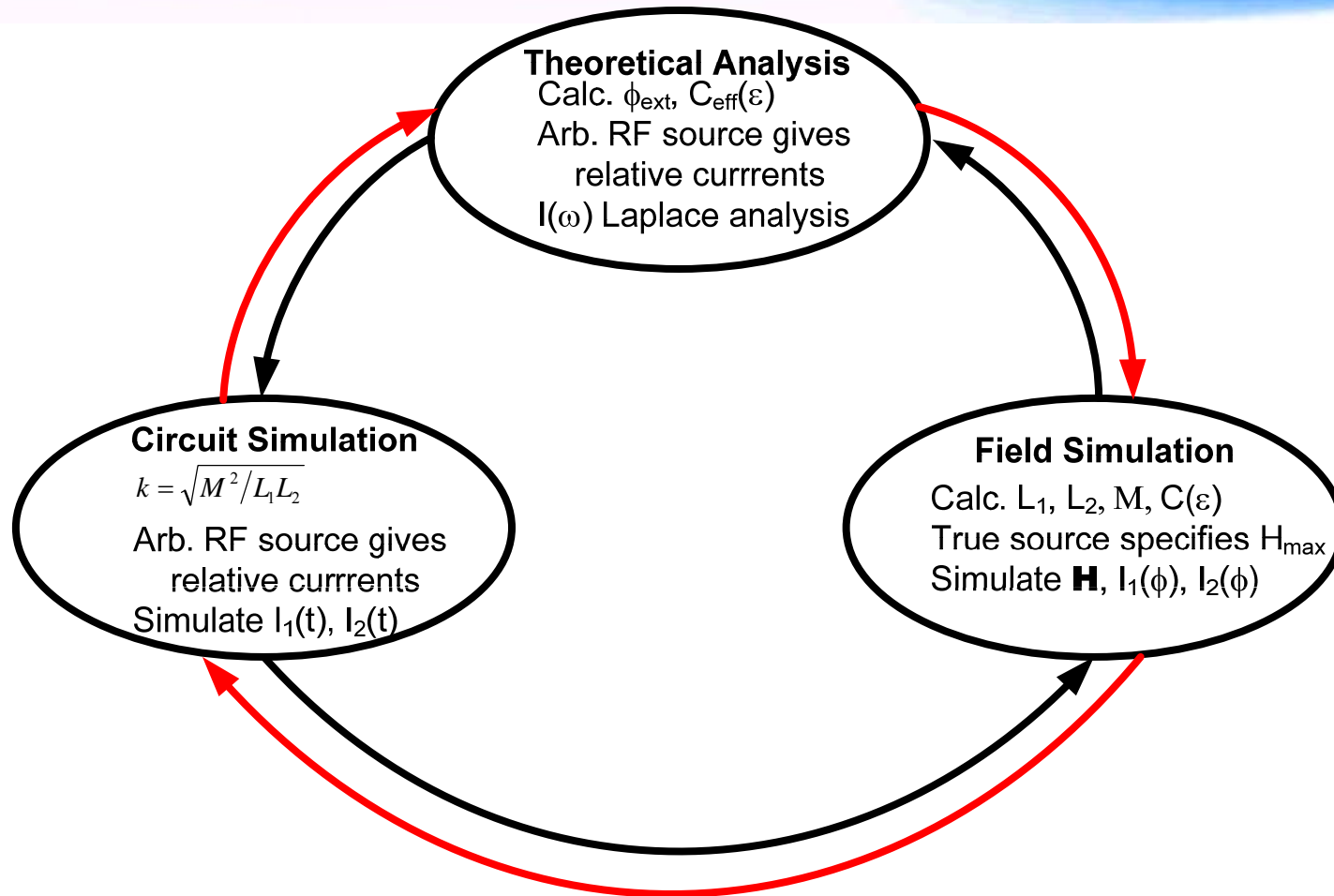

RF-Stent-Coating Equivalent Circuit

- Inductance and capacitance lumped parameter values computed via Maxwell.

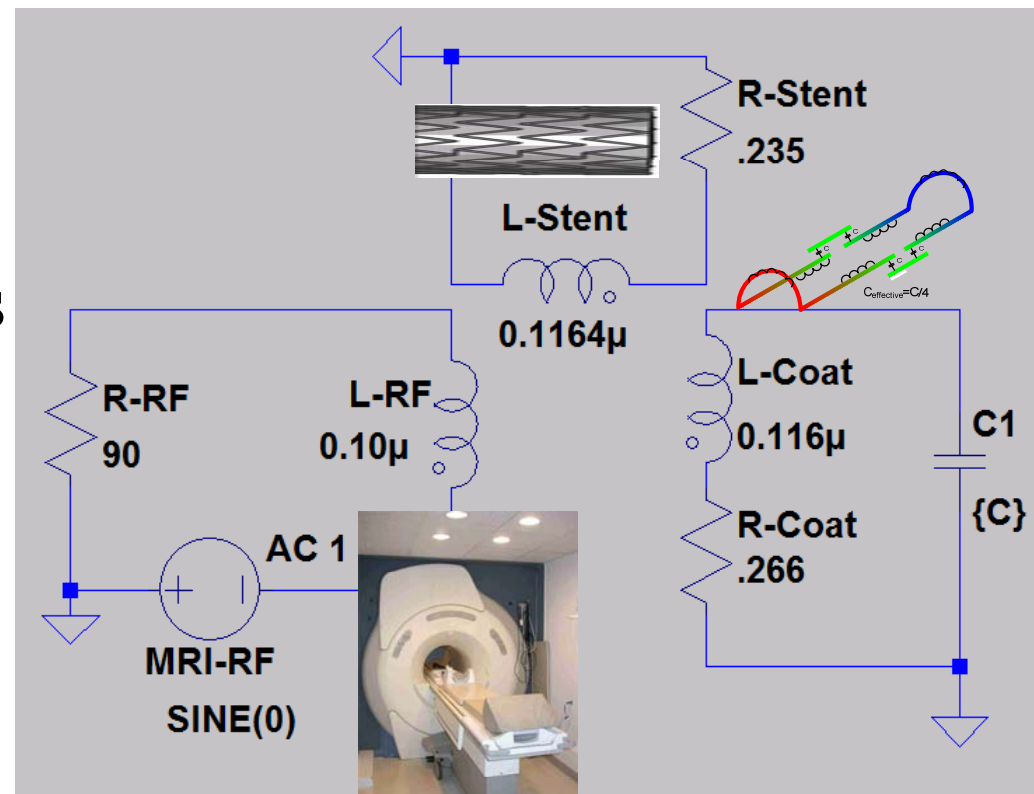

RF-Stent-Coating Equivalent Circuit Results—94% correction

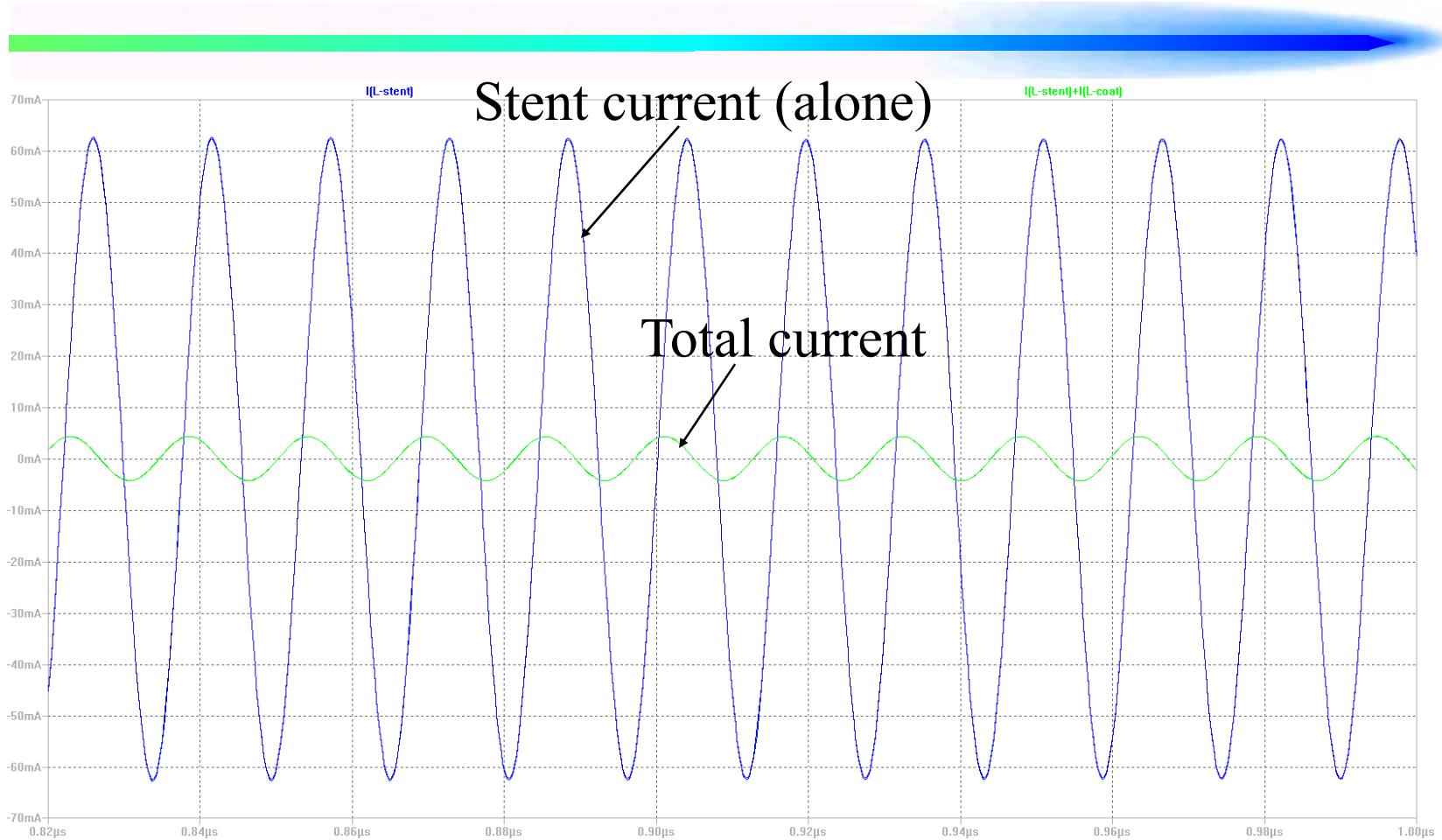

Equivalent Circuit Frequency Sweep Results—94% cancellation

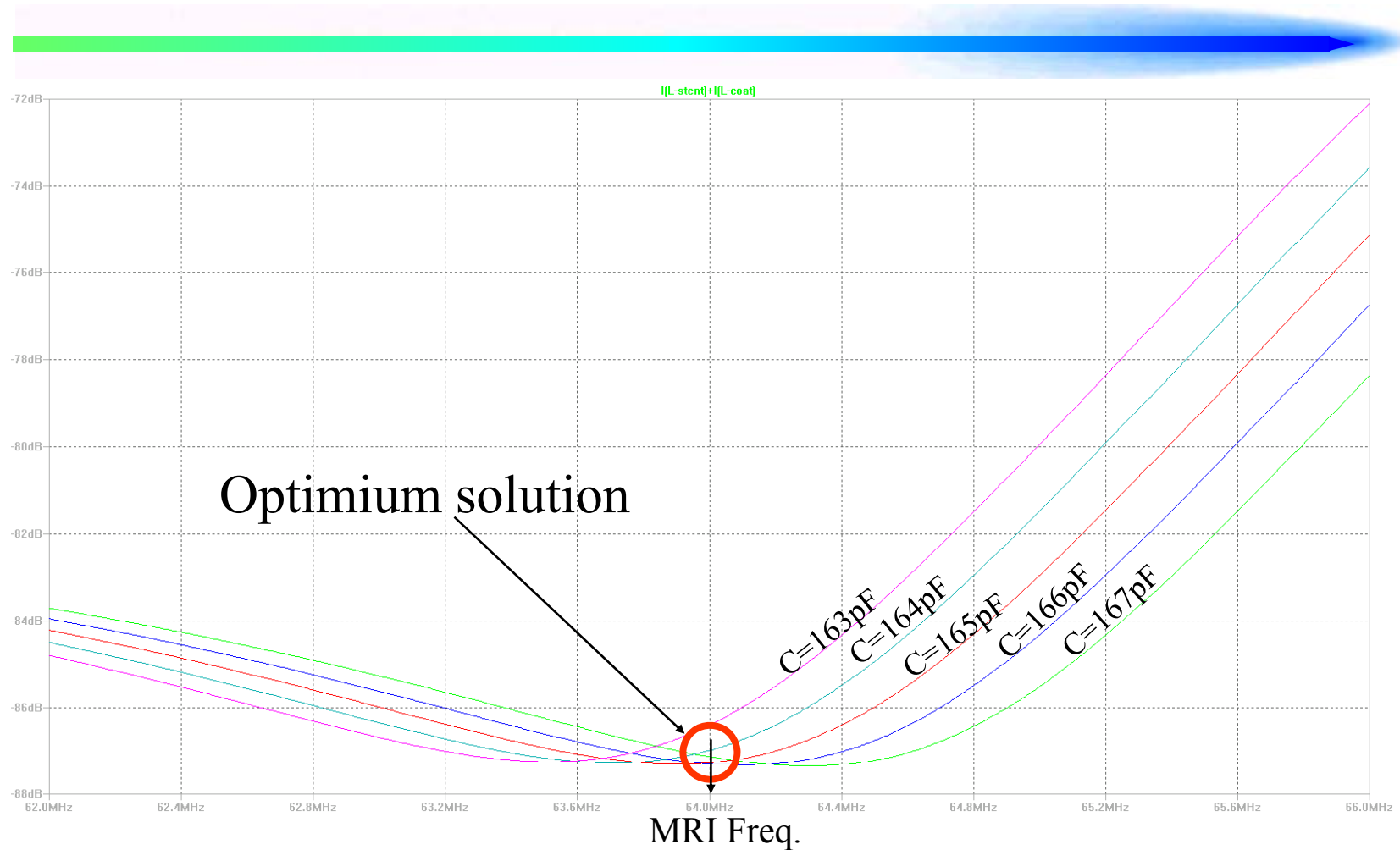

Equivalent Circuit Frequency Sweep

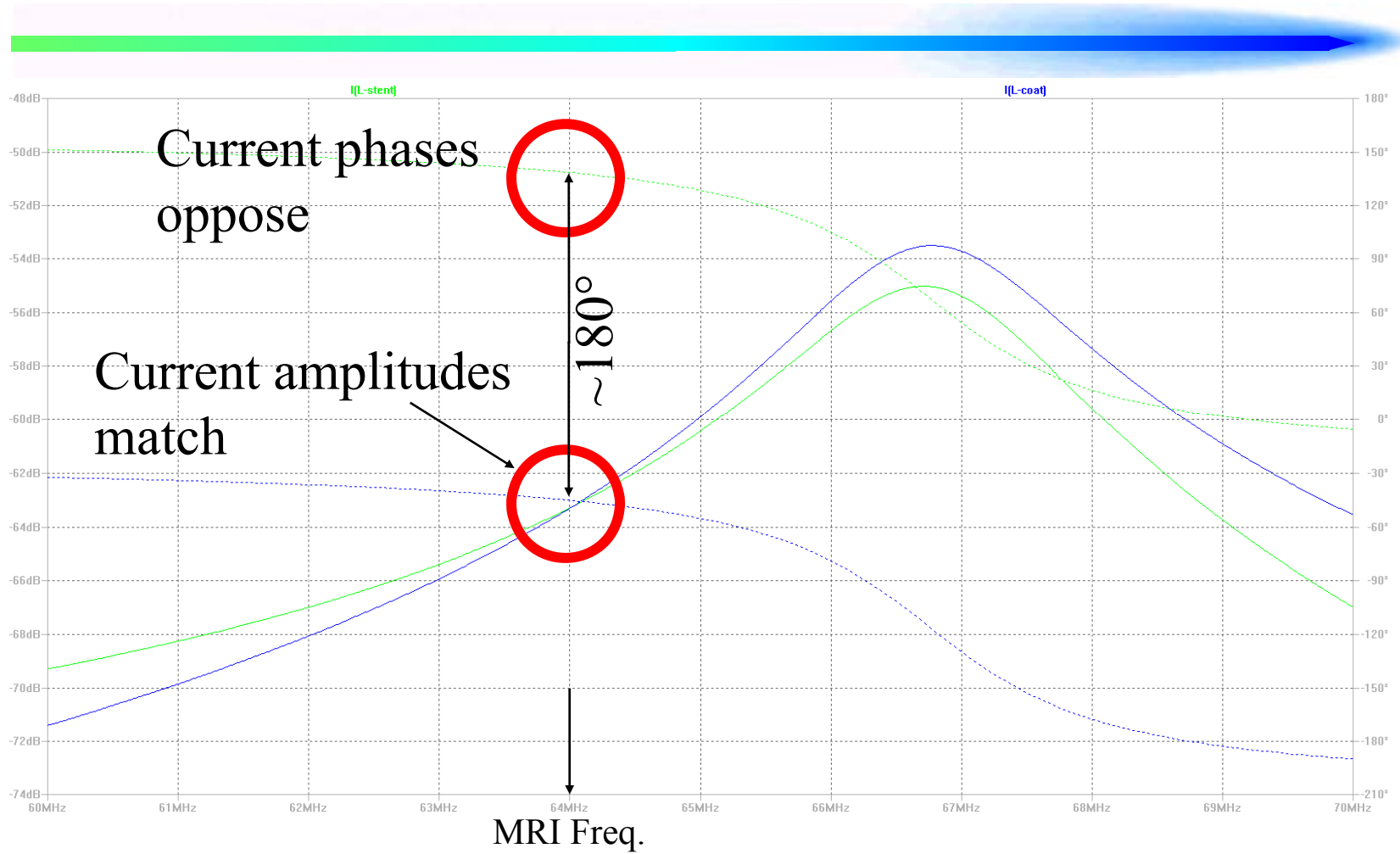

Complex Plane Analysis

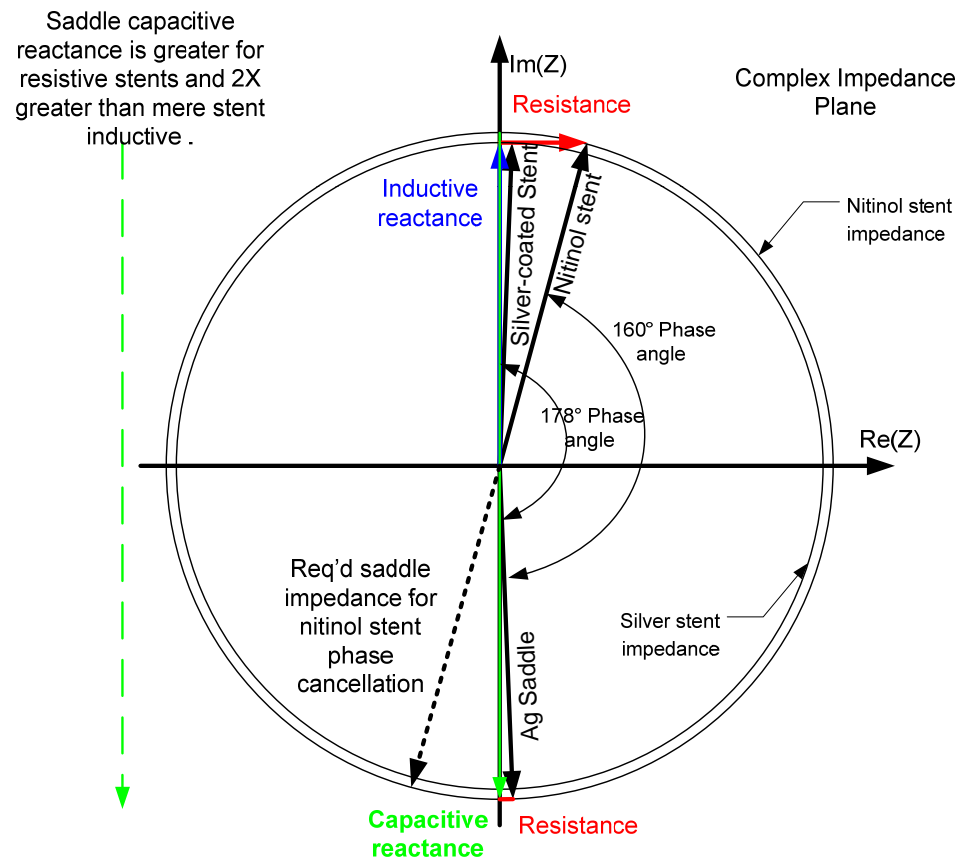

Stent Imaged in MRI without/with Resonator to correct fields

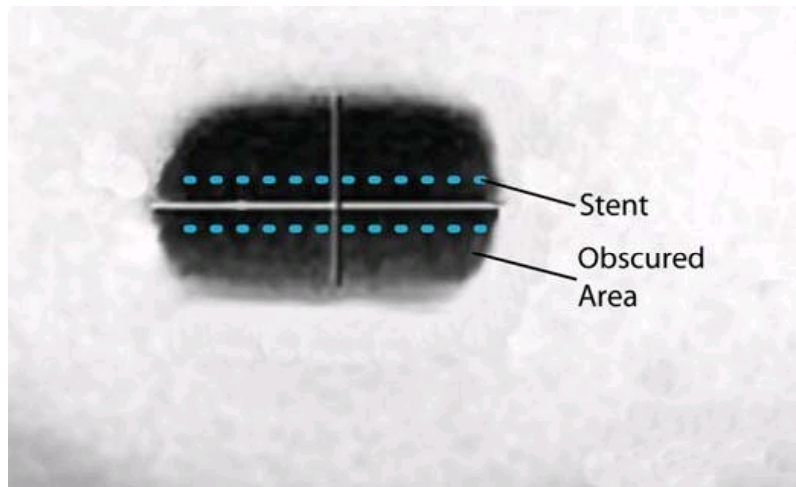

Uncompensated stent perturbs fields and produces poor imaging.

Resonator stent Blood clot

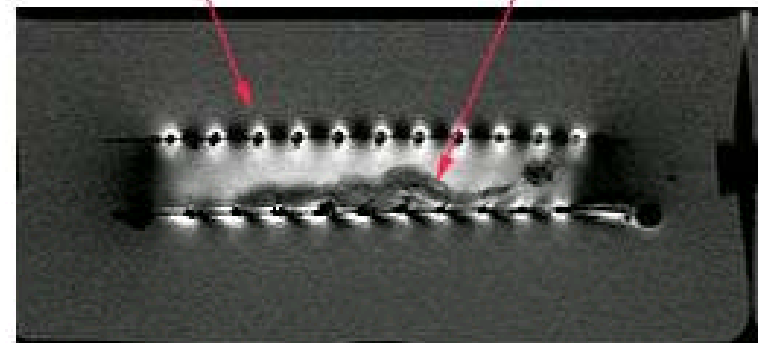

Stent resonant compensation corrects disruptive fields and allows imaging.

http://www.biophan.com/index.php?option=com_content&task=view&id=384&Itemid=359, 14 October 2007

Stent Ring and Peg Models—Simple structures that provides rich physics

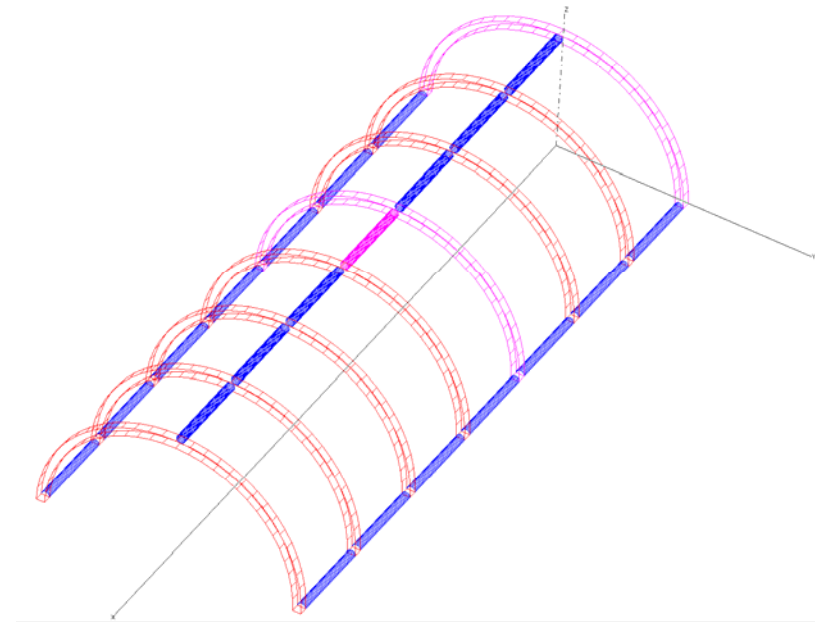
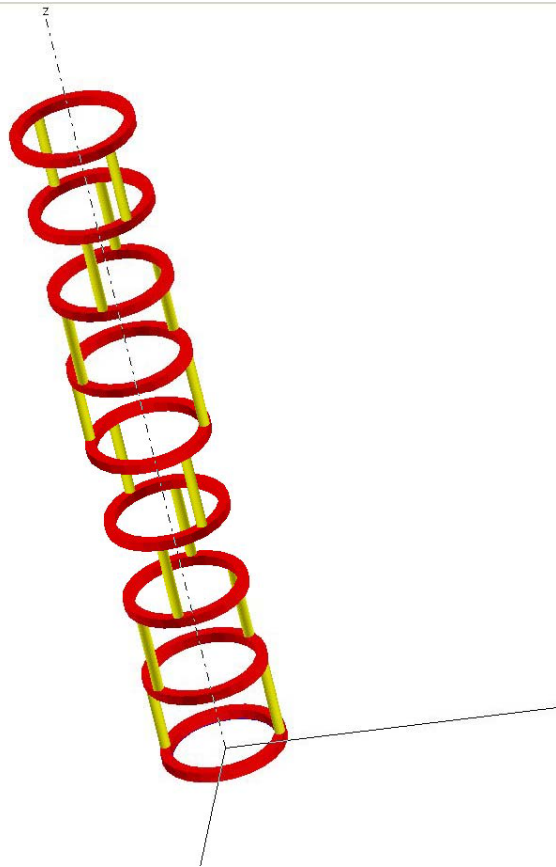

Many Coating Configurations Simulated

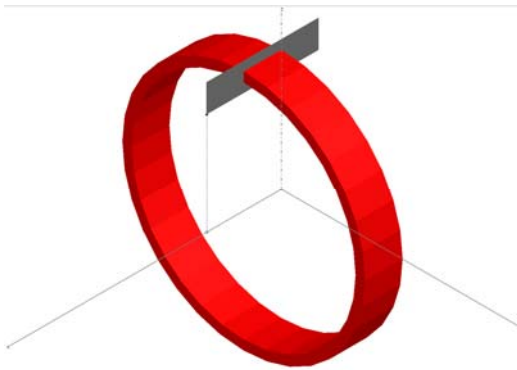

Capacitive Flange with
Split Ring

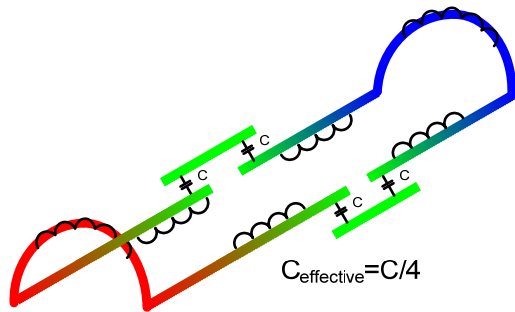

Saddle Coils with Caps

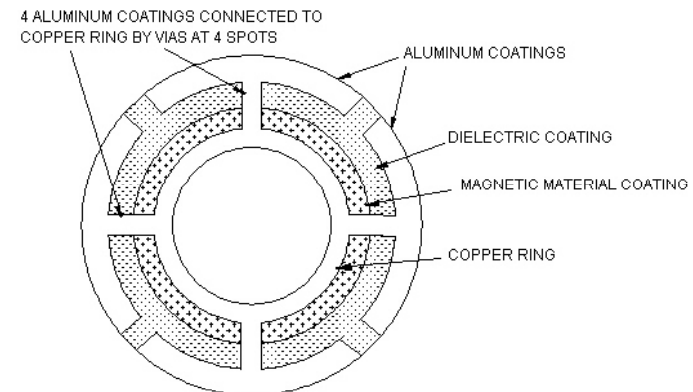

Quad Vias with Caps

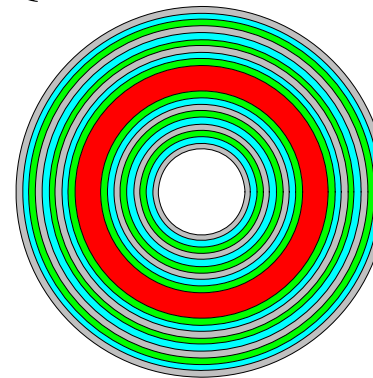

3x3 Nested Rings

Saddle Coil Close-up

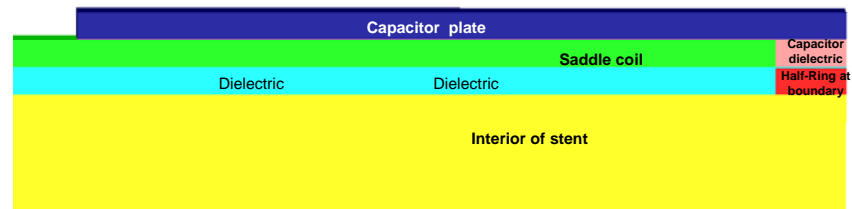
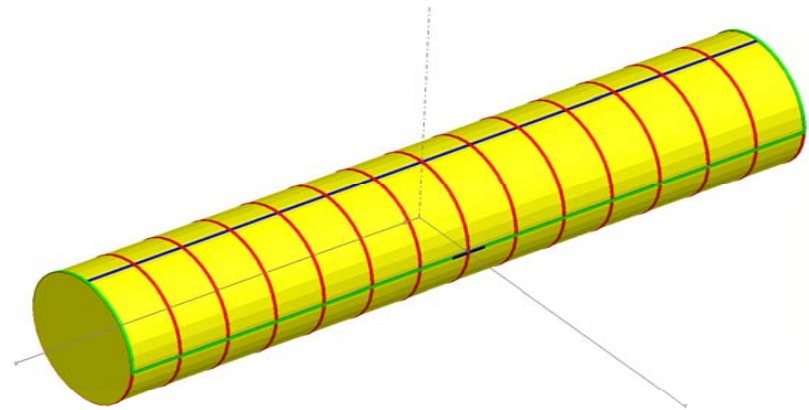
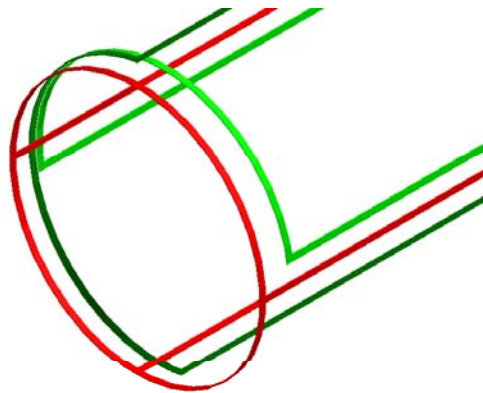
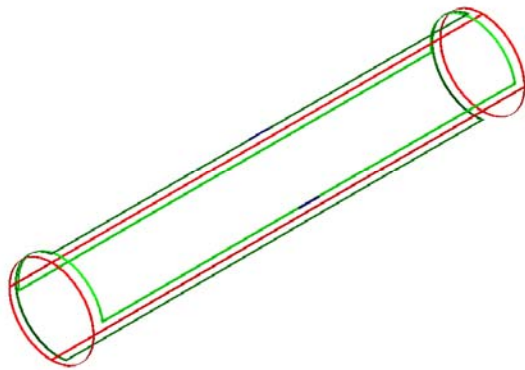
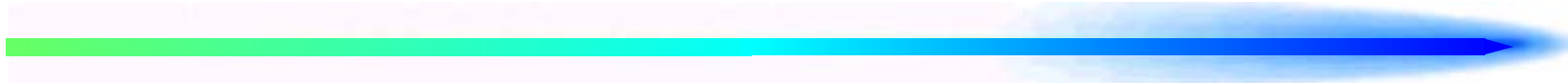

Umbrella Design

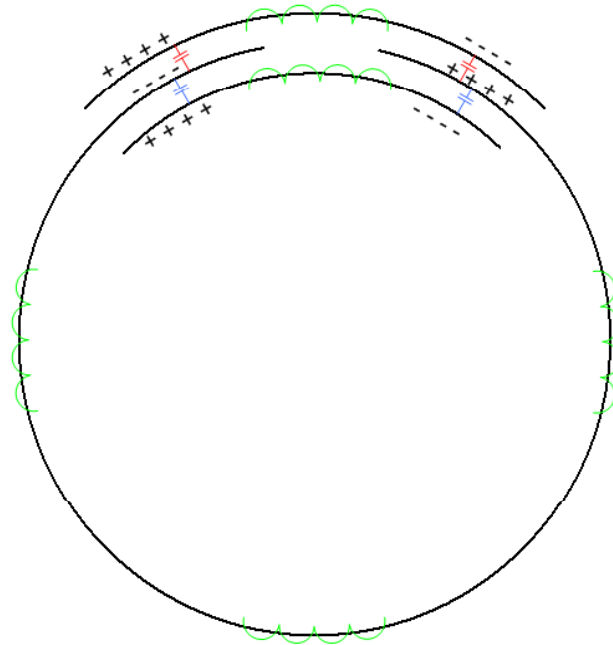
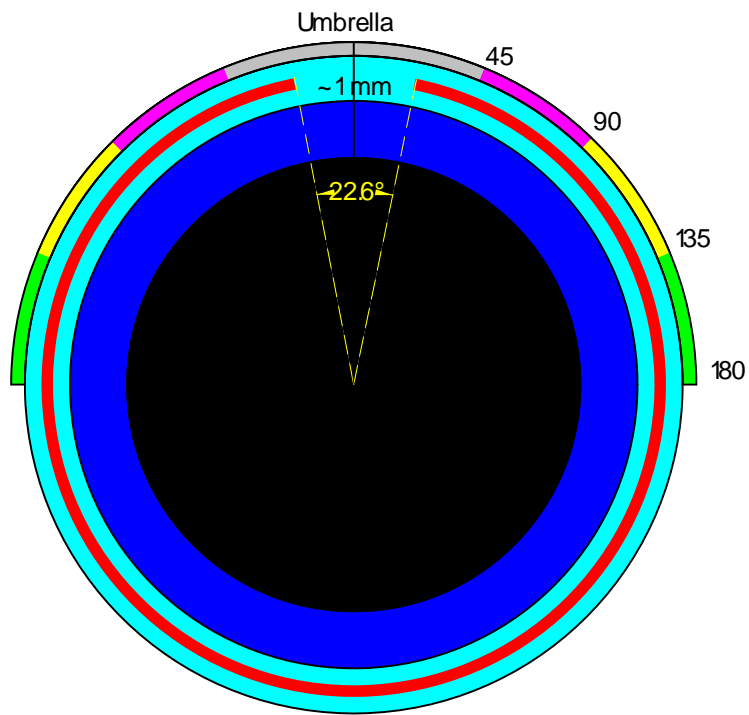

Distributed Circuit Elements Successfully Correct Stent Fields

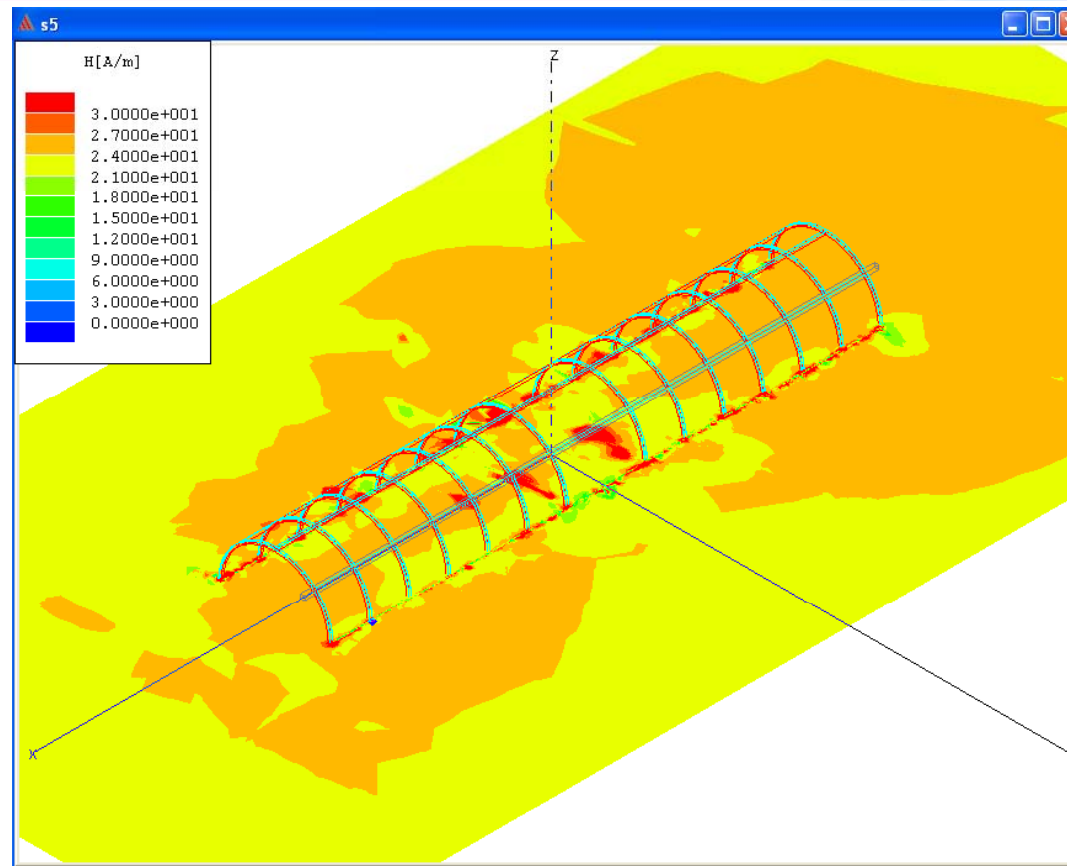

Lightweight Transformer Goals

- Develop a “black box” which achieves power conversion similar to a traditional 60 Hz iron-core transformer at greatly reduced size & weight.



Lightweight Transformer Objectives



- Develop power electronic architectures achieving desired characteristics
- Develop detailed critical components:
 - High frequency transformer
 - High current inductor

Ansoft Maxwell 3D



- The magnetostatic solution includes non-linear effects such as permanent magnets and BH relationships.
- The magnetostatic solution also computes matrix inductances and parasitic capacitances.

Electronic Transformer Architecture

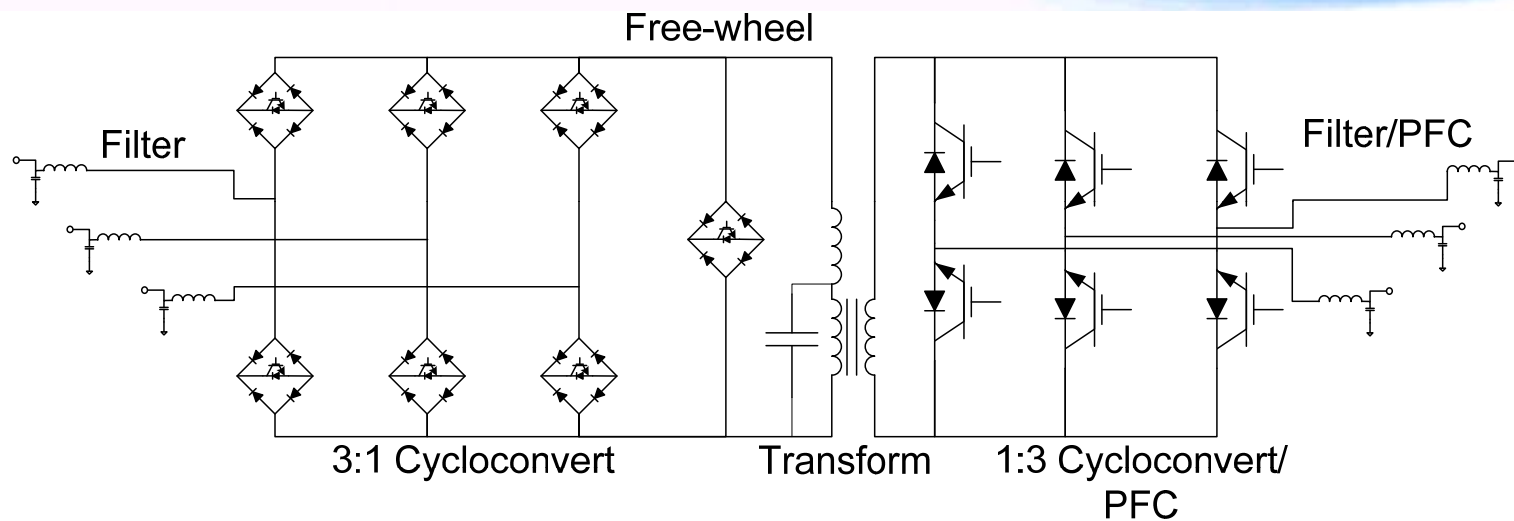

- High system efficiency (97.4%).
- Power reversibility, power factor correction, voltage regulation, and variable voltage variable frequency operation.

Eddy Currents and Magnetic Saturation Complicate Design

Automatically taken into account in Maxwell

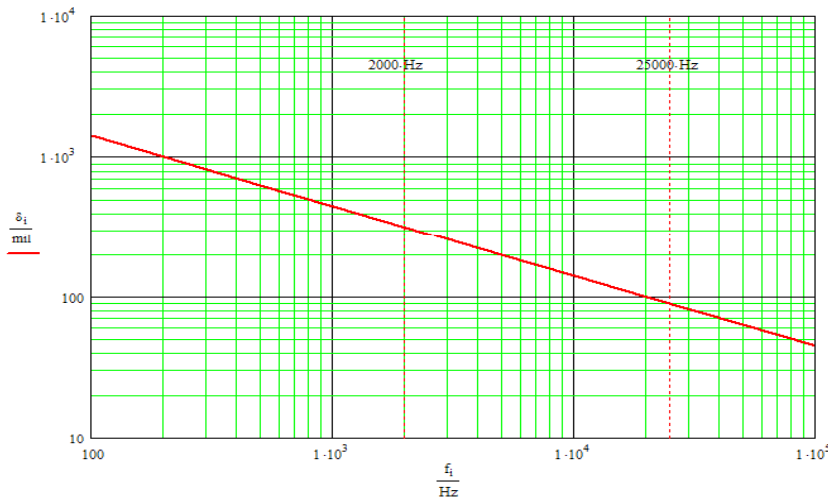

Copper Skin Depth vs. frequency

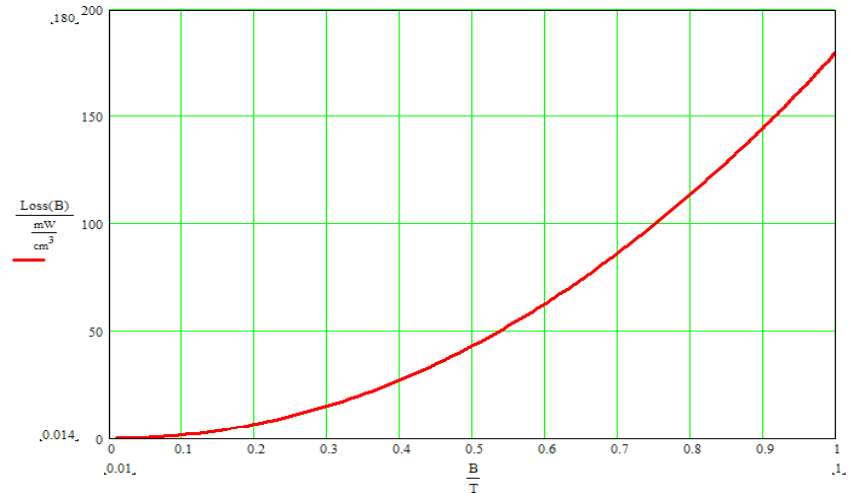

Core loss dependence upon magnetic field

Simulation Model and Prototype Transformer

Measured results match predicted results to ~5%

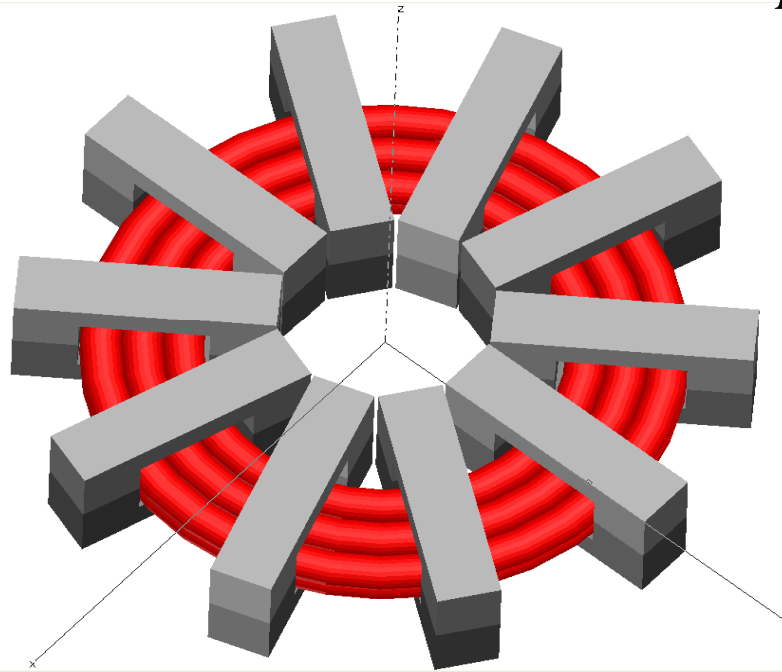

FEA model of 167kVA XFMR

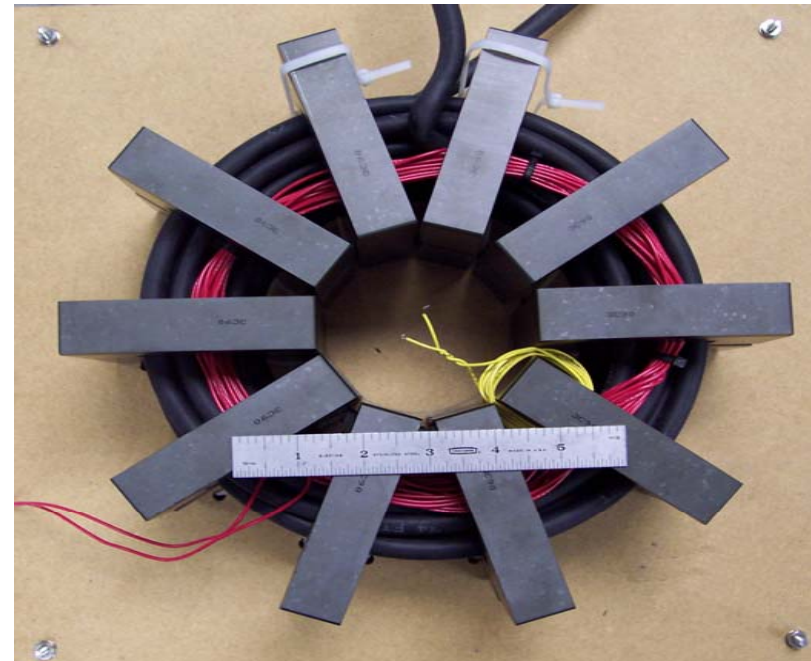

Full-scale 167 kVA, 25kHz transformer.

Permanent-Magnet Biased Inductor

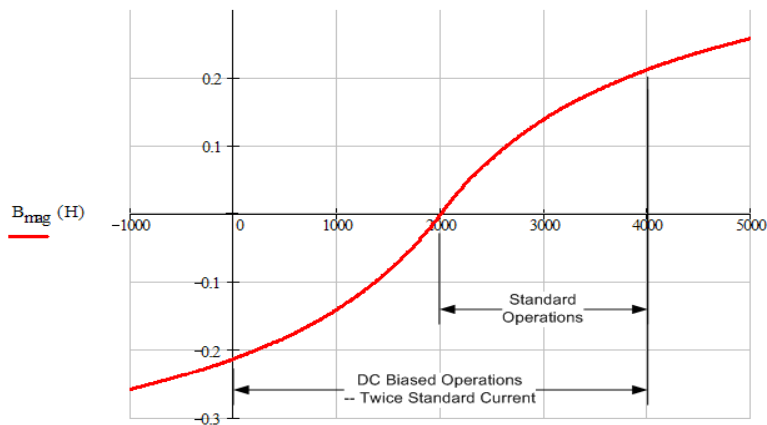

BH curve for the permanent magnet-biased inductor.

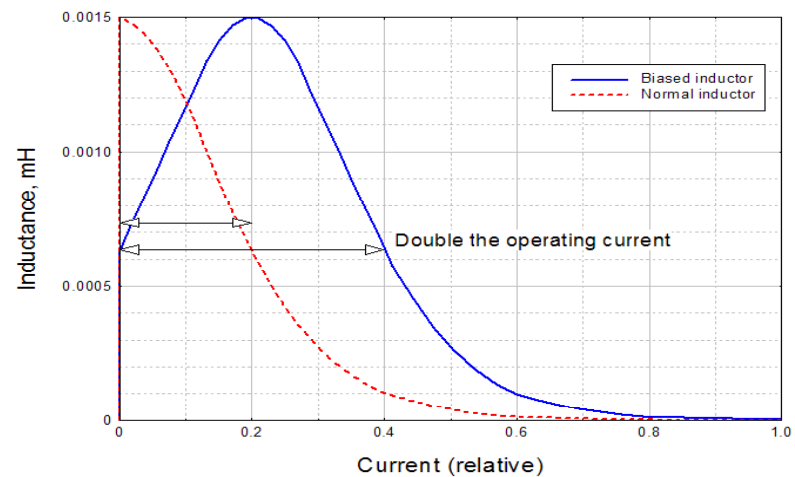

L vs I for the biased non-linear BH curve.

Permanent-Magnet Biased Inductor

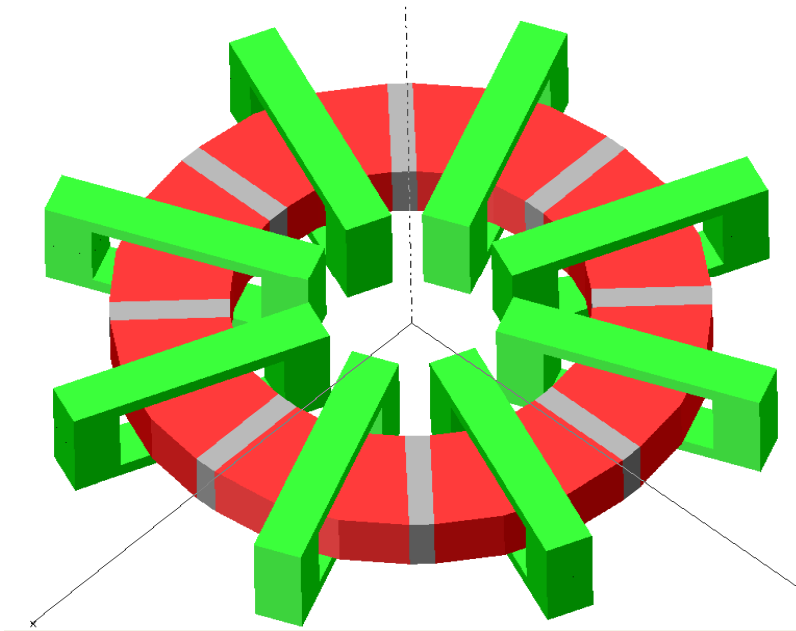

- Finite Element Analysis model of the biased inductor. The design ratings are: $L \sim 10 \text{ mH}$, $I = 2500 A_{\text{pk}}$, $1400 A_{\text{rms}}$.
- Poloidal coils are green structures, toroidal (powdered iron) ferromagnetic cores are red structures, and the Ceramic 8 permanent magnets are gray rectangular solids.
- Very cost-effective, high performance inductor.

PM Biased Inductor Results

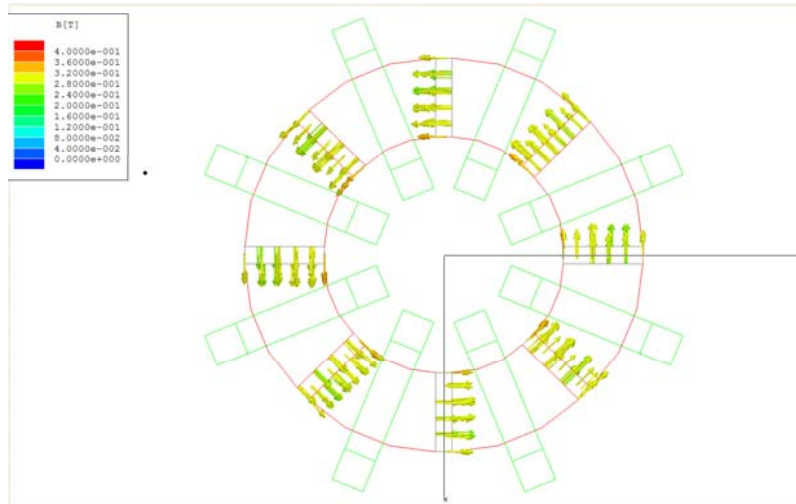

Zero current permanent magnet field showing the counter-clockwise flux rotation.

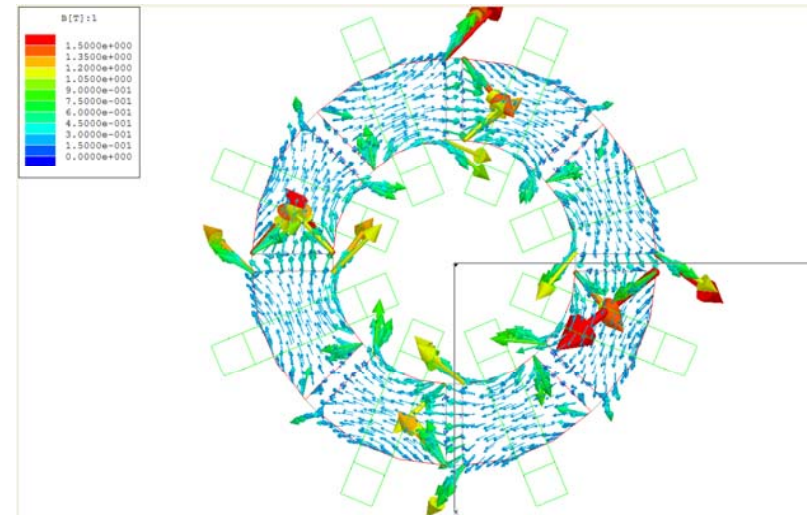

4000 Amp inductor excitation showing the net clockwise flux rotation.

2.7 MVA 2080V/450V Electronic Resonant Transformer.

- Fully Reversible
- Power Factor Corrected
- Voltage Regulation
- Variable Voltage
Variable Frequency
- Efficiency = 97.4%
- Size = 1.5 m³
- Mass = 1000 kg
- Reduction of 83% in size and mass.

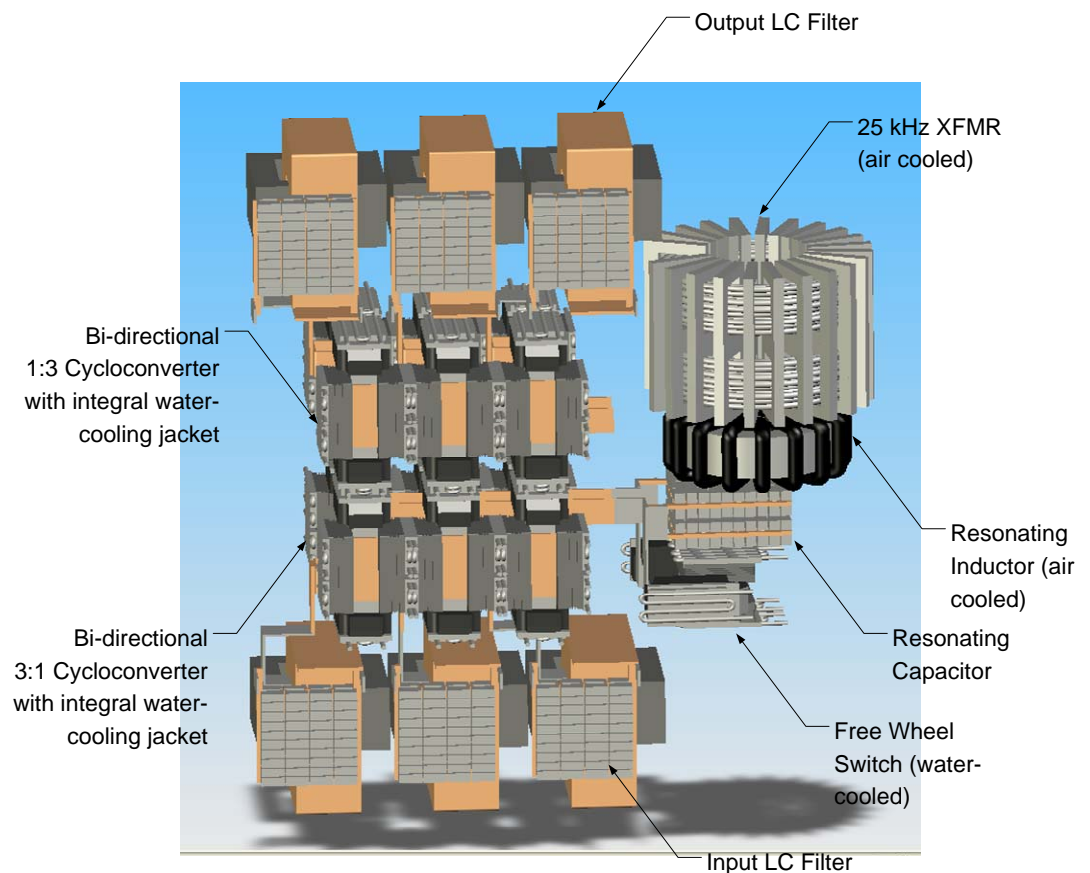

Summary



- MRI Visible Stent Resonant Inductor and Capacitor
 - Maxwell 3D calculates distributed LRC values and radiative resonance effects.
 - Excellent agreement with lumped parameter models (values calculated in Maxwell).
 - An MRI visible stent was designed and developed. MRI trials and further development are on-going.
- High Frequency Electronic Transformer
 - Maxwell 3D calculates non-linear PM and BH effects, inductive matrix couplings and parasitic capacitances.
 - High frequency transformer and high current inductor designed.
 - Lightweight, efficient electronic transformer developed.
 - Excellent agreement with measurements.

Acknowledgements



- Stent development done under contract to Biophan Technologies, Inc.
- David Fischer of DMF Associates designed the advanced transformer power electronics.
- Transformer work under SBIR contract N00014-05-M-0028 to Office of Naval Research.
- All rights reserved.