



# FIRST PASS SYSTEM SUCCESS

APPLICATION WORKSHOPS FOR HIGH-PERFORMANCE ELECTRONIC DESIGN

## WiMax MIMO Circuit and System Design

Presenter: Eldon Staggs

Authors: Jim DeLap, John Borelli, Tony Donisi, Eldon Staggs

*Ansoft Corporation*

# Mobile WiMax System

- WiMax System Modeling
  - Behavioral, Circuit and Physical

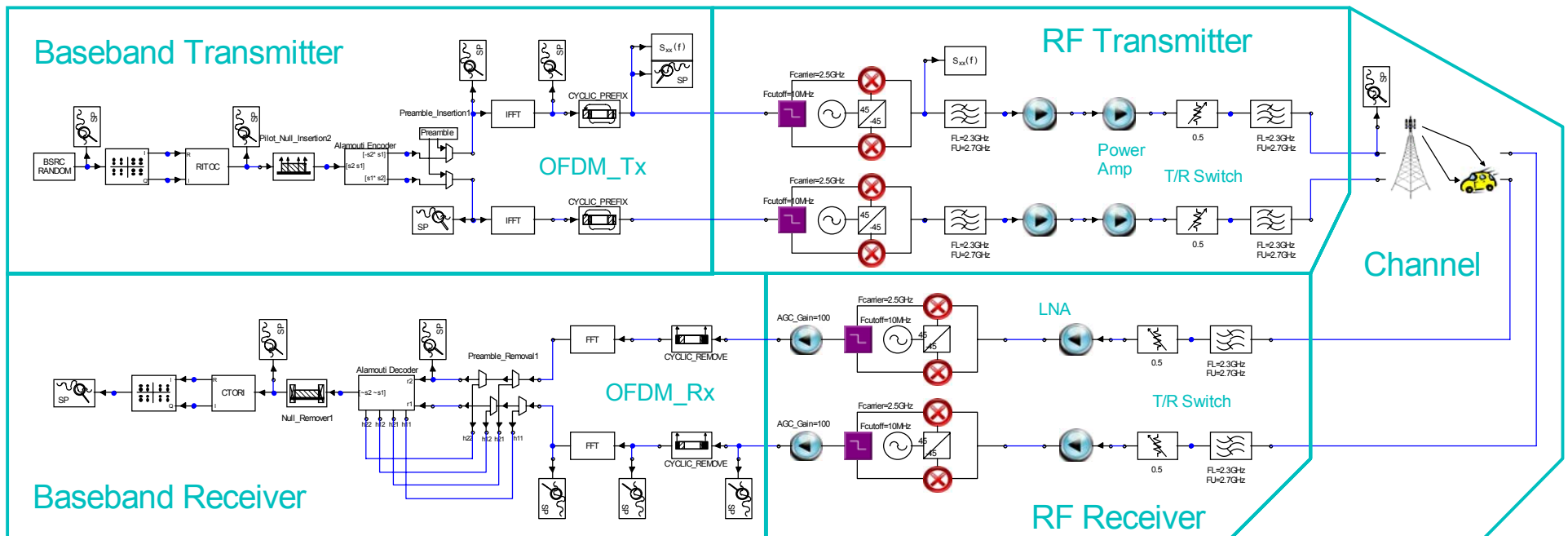

# Agenda



Introduction to Mobile WiMax

System Architecture

MIMO Antennas

Receiver Circuit

Integration

Conclusion

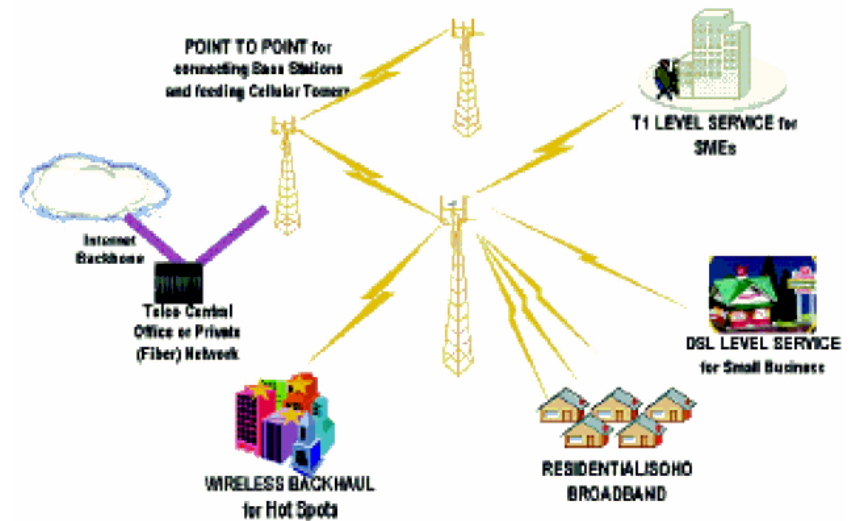

# WiMAX - Mid Range IEEE Communication Standard

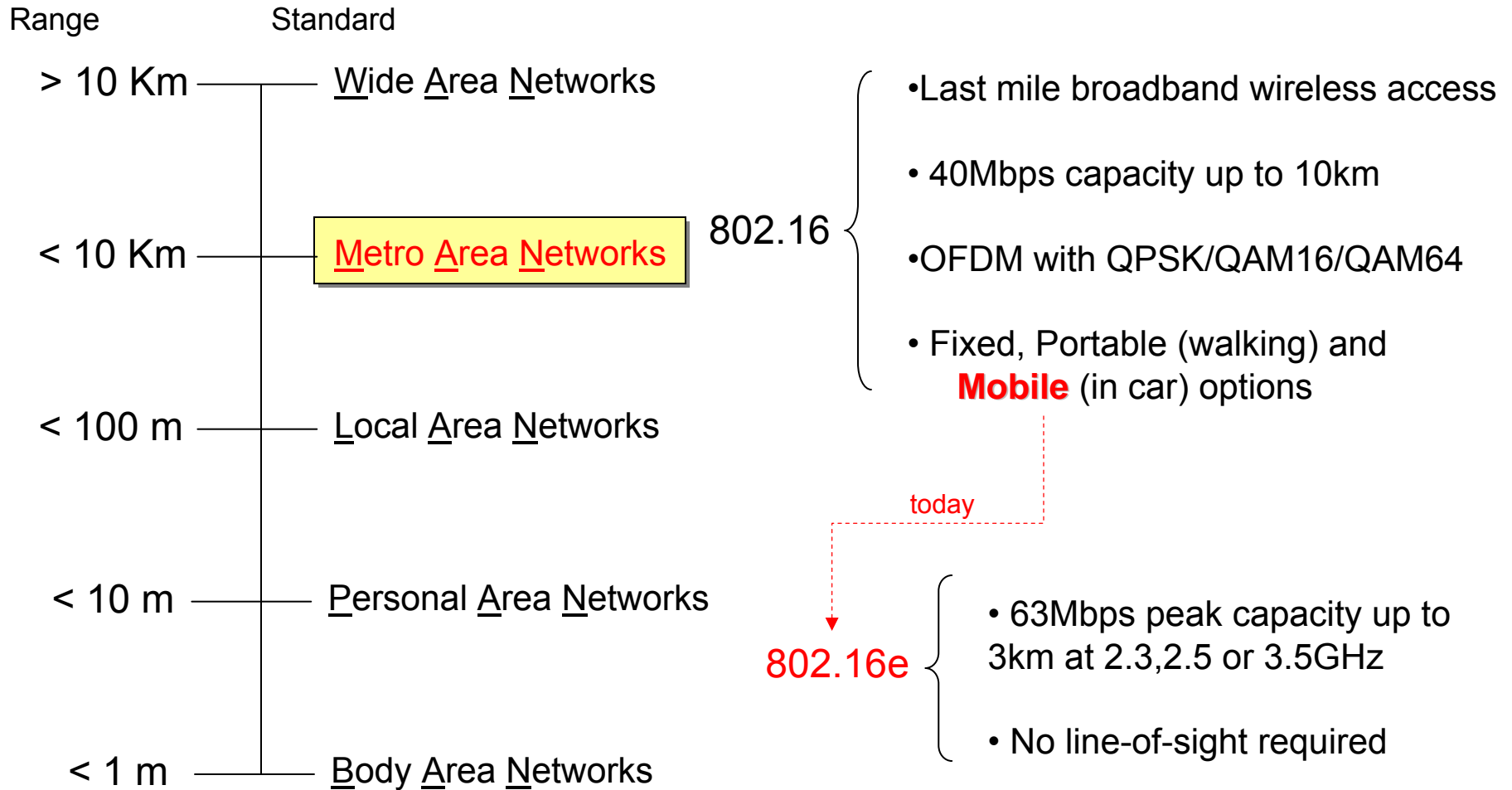

Our focus today is Mobile WiMAX, a standard designed to enable high data rate applications such as the wireless Internet.



# WiMAX Architecture Based on 2 Core Features: MIMO & OFDM

Our examples today will illustrate how **MIMO** and **OFDM** can be simulated.

## 1. MIMO (Multiple Inputs Multiple Output = Many Antennas)

- **Advantage:** More antennas means more data or reliability. For example, if 2 TX and RX antennas are present, then data rate should double.

**Data rates will scale linearly.**

- **Challenge:** How to design system so that interactions between multiple TX and RX are minimized.

**Solutions**, thus far, have emphasized 4 **diversity** schemes:

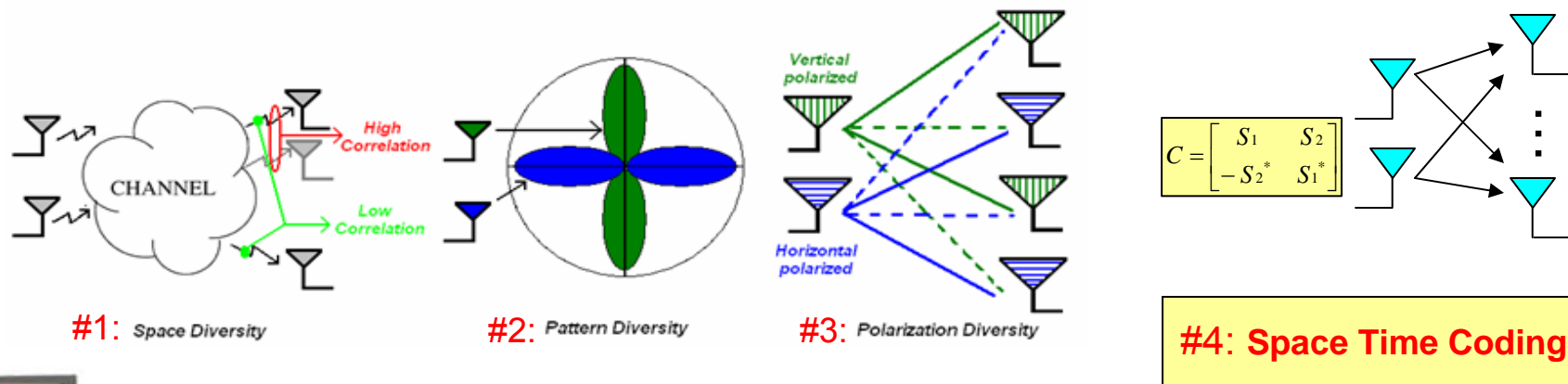

# WiMAX Architecture Based on 2 Core Features: MIMO & OFDM

Our examples today will illustrate how **MIMO** and **OFDM** can be simulated.

## 2. OFDM (Orthogonal Frequency Division Multiplexing)

### – Advantages:

- Relative immunity to multi-path effects
- Multiplexing schemes, using IFFT & FFT, are easily implemented
- Low sensitivity to time synchronization errors
- Tuned sub-channel receiver filters are not required (unlike conventional FDM)

### – Challenges:

- Sensitive to Doppler shift
- Sensitive to frequency synchronization
- High peak-to-average-power ratio (PAPR), requiring more expensive transmitter circuitry, and possibly lowering power efficiency

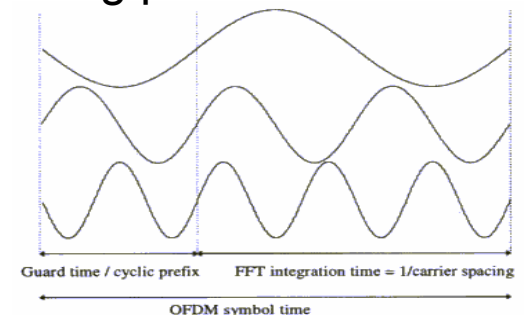

# Mobile WiMax Details

- Flexibility
  - All aspects can change dynamically to suit the channel
- WiMax MIMO 2x2 Configuration
  - Beamforming
  - **Spatial Multiplexing**
    - Complicated algorithms for data rate increase
    - Data rate scales with  $\min(N_{tx}, N_{rx})$  antennas
  - **Space Time Coding**
    - Diversity gain with easy implementation
- OFDM Implementation
  - Sub-carrier and Symbol times fixed
  - BW usage dictated by IFFT length
  - Downlink Data Rate

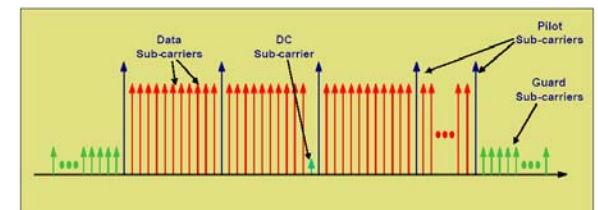
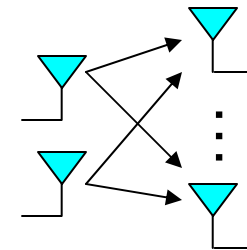
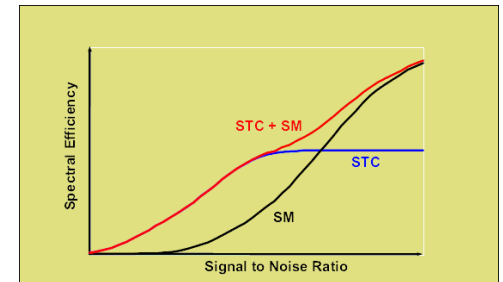

# System Architecture

Behavioral

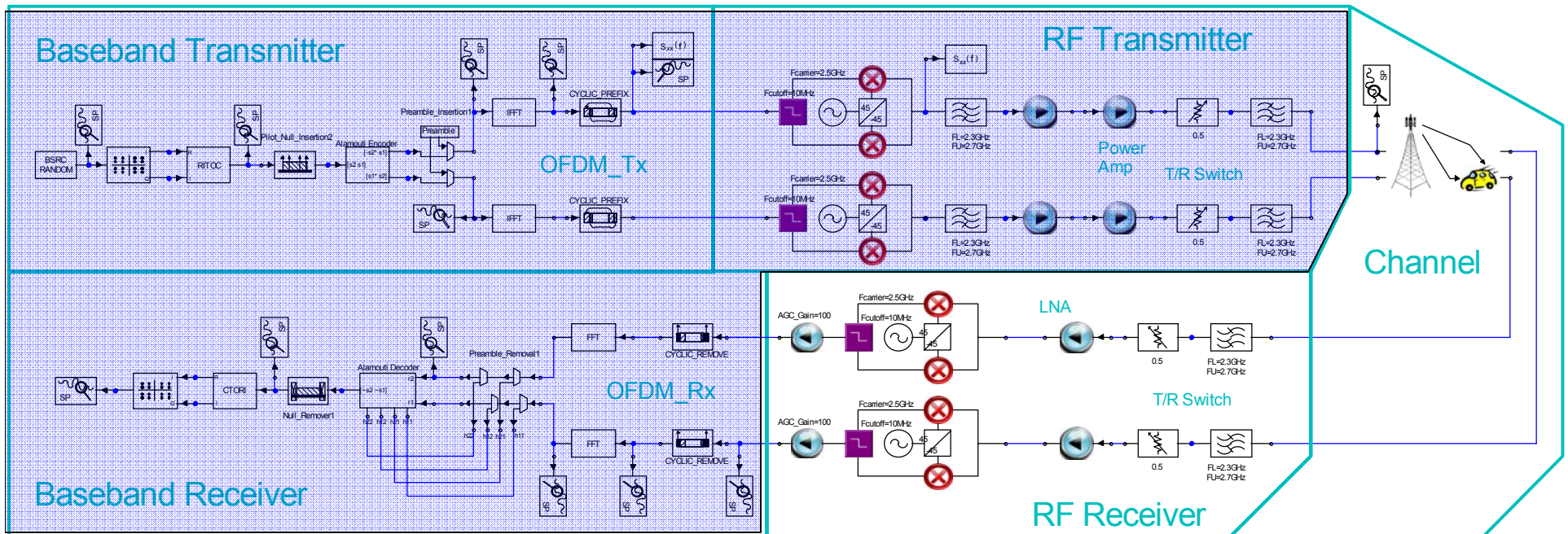

# Baseband Modeling

- OFDM Modeling

- Guard Band
- Cyclic Prefix
  - Delay Spread & Multipath Immunity

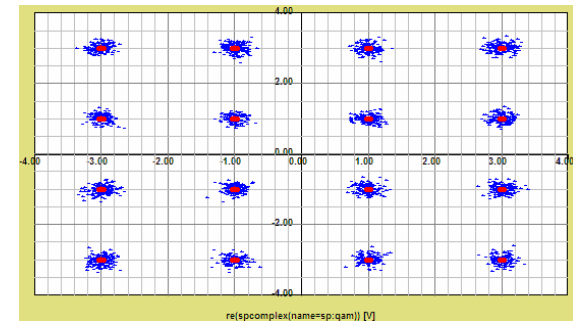
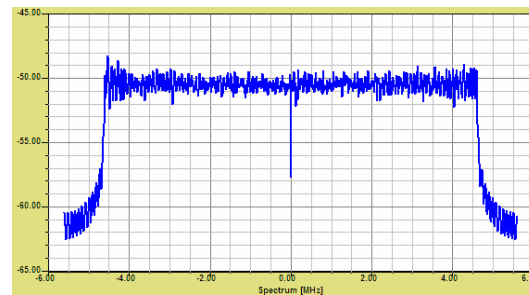
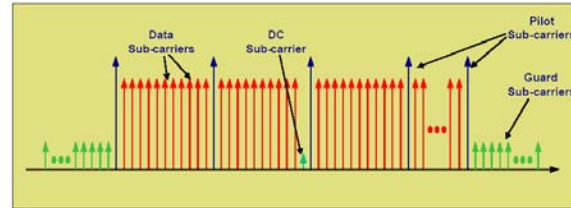

- QAM Modulation
  - 4/16/64 Supported

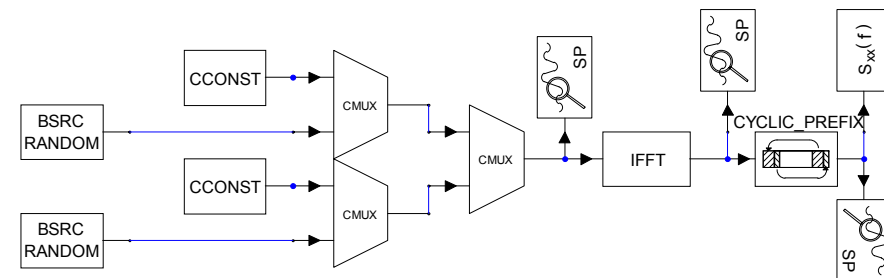

# Baseband Modeling

- Channel Detection
  - Excite Transmit Antennas separately
    - Initial frequency estimation
  - Pilots
    - Dynamic estimation

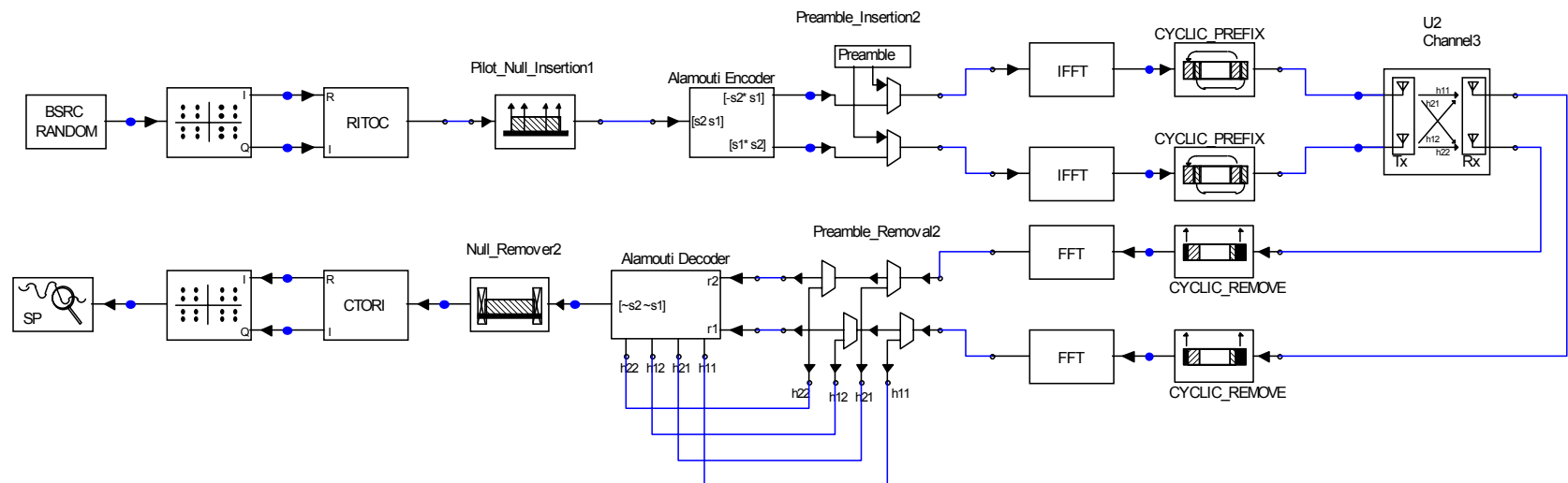
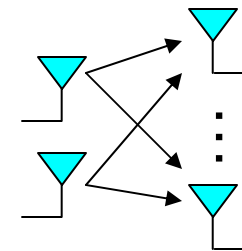

# Baseband Modeling

- Space Time Coding
  - Orthogonal Alamouti Codes

$$C = \begin{bmatrix} S_1 & S_2 \\ -S_2^* & S_1^* \end{bmatrix}$$

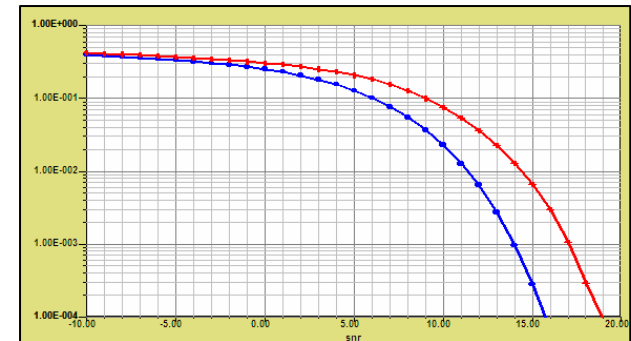
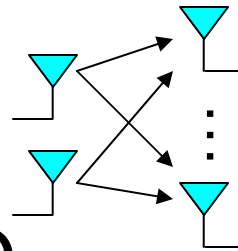

- SISO vs MIMO
  - Diversity gain

$$\tilde{S}_1 = \sum_{j=1}^{M_r} (h_{j1}^* \cdot r_j[0] + h_{j2} \cdot r_j[1]^*)$$

$$\tilde{S}_2 = \sum_{j=1}^{M_r} (h_{j2}^* \cdot r_j[0] + h_{j1} \cdot r_j[1]^*)$$

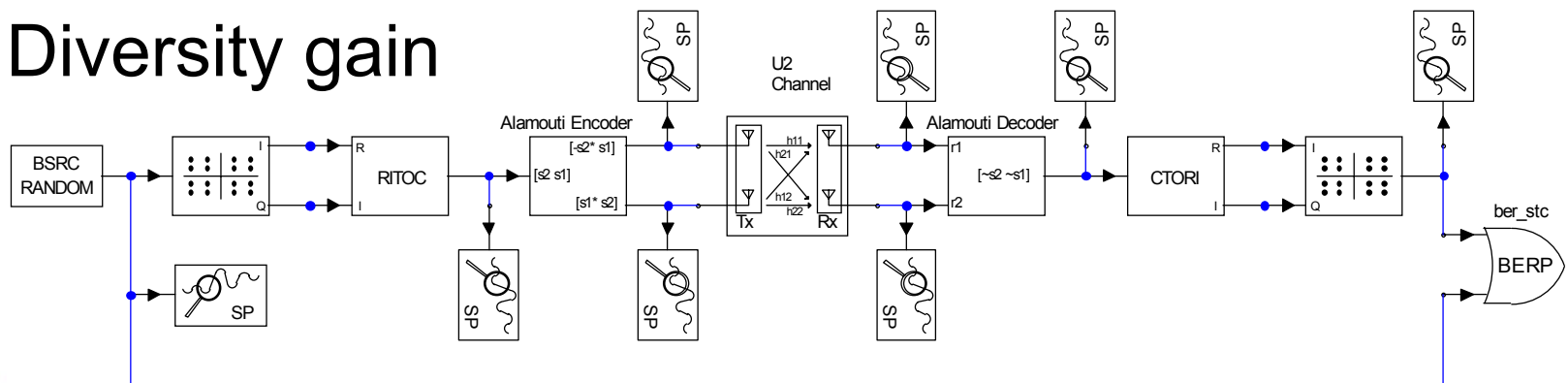

# MIMO Antenna Design

Physical

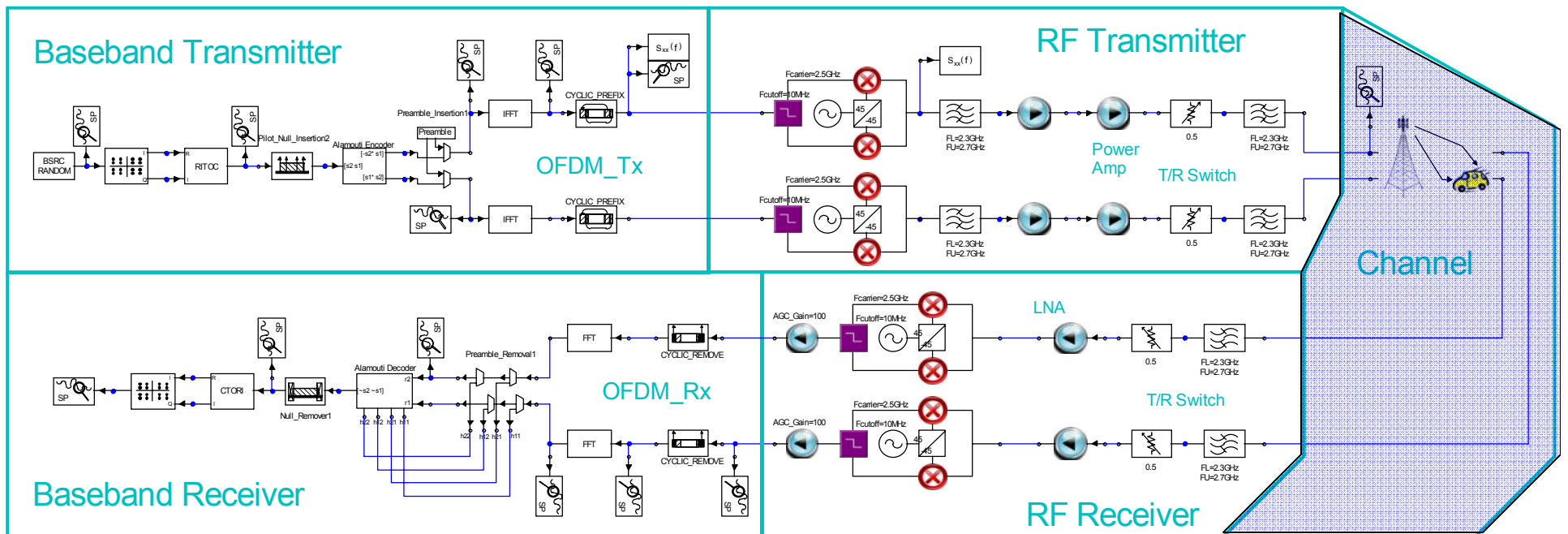

# WiMax Physical Channel

- Simplified Channel Model
  - Path Loss with Friis Transmission equation
  - Non-Ideal effects often ignored
    - Element coupling, Mismatch, Orientation
  - Single value for Antenna gains

$$\frac{P_r}{P_t} = G_t G_r \left( \frac{\lambda}{4\pi R} \right)^2$$

$$\frac{P_r}{P_t} = G_t(\theta_t, \phi_t) G_r(\theta_r, \phi_r) \left( \frac{\lambda}{4\pi R} \right)^2 (1 - |\Gamma_t|^2)(1 - |\Gamma_r|^2) |a_t \cdot a_r^*|^2 e^{-\alpha R}$$

- More Accurate Channel Model
  - Full-wave 3D EM modeling with HFSS
  - System Non-linearities
    - Multi-path, Fading, etc.



# WiMax Physical Channel

- Antenna Configurations
  - SISO and full 2x2 MIMO
  - Designs centered at 2.5GHz

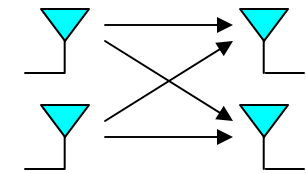
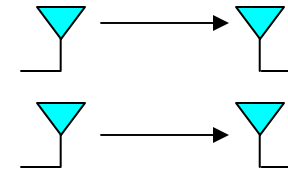

- Mobile Station
  - Laptop with WiMax Modem PC Card
  - Simple Radiating Monopoles

- Base Station
  - Reflector backed Dipoles

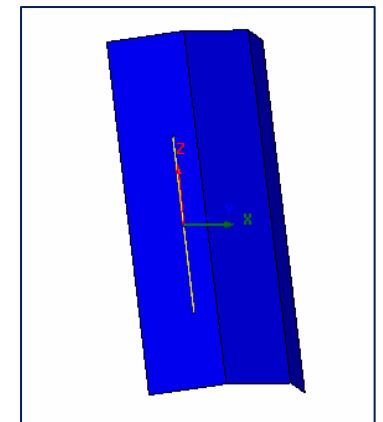
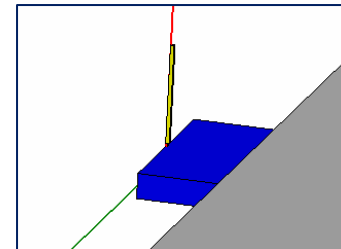

# Mobile Station Antenna

- Tuned Monopole
- Monopole Response
  - Far Field
  - Return Loss

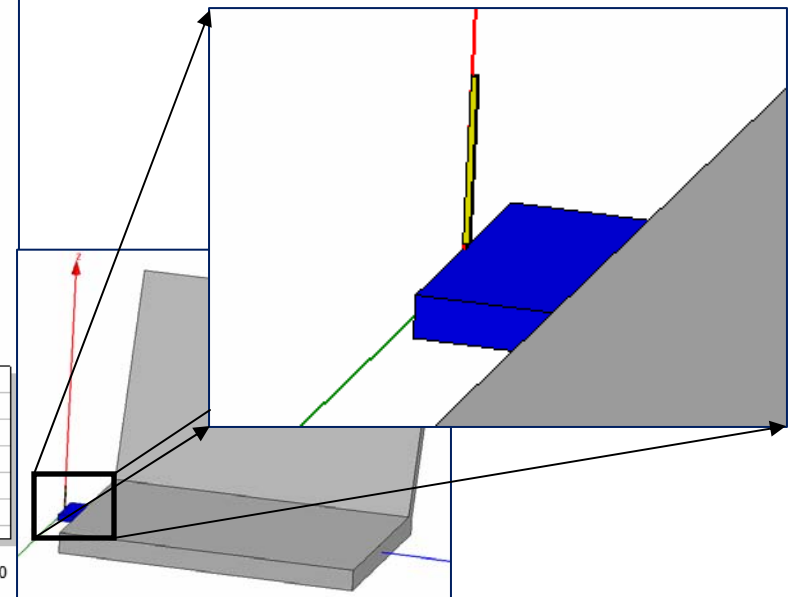
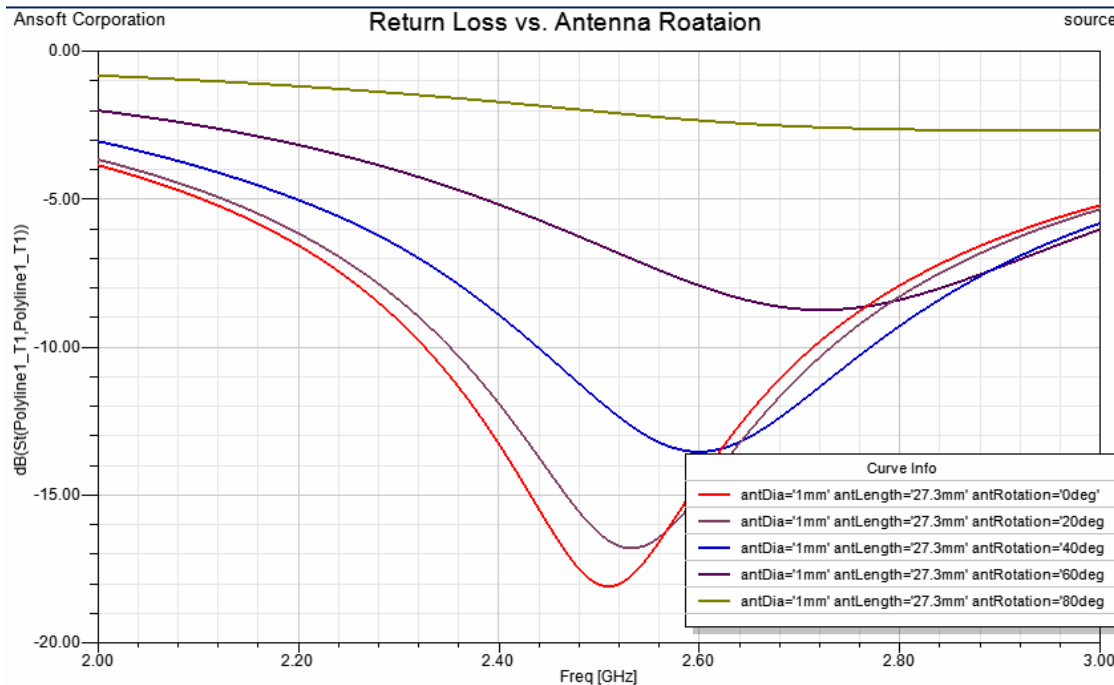
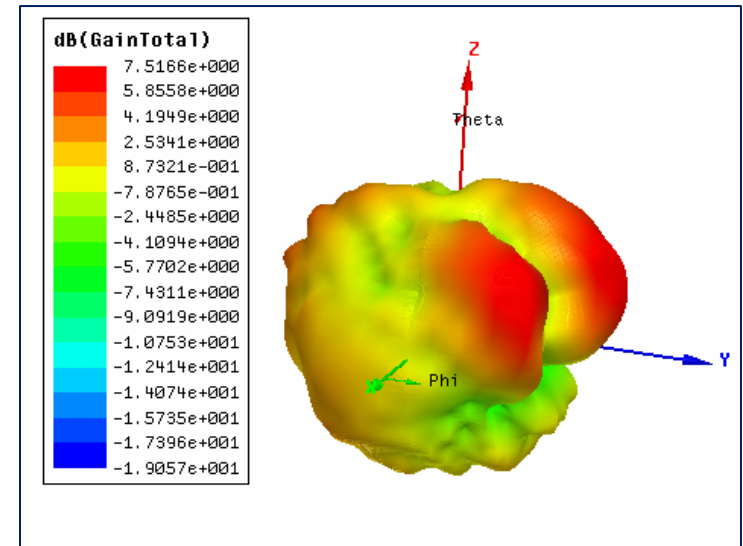

# Base Station Antenna

- Reflector Backed Dipole
  - Optimized for Directivity
- Dipole Response
  - Far Field
  - Return Loss

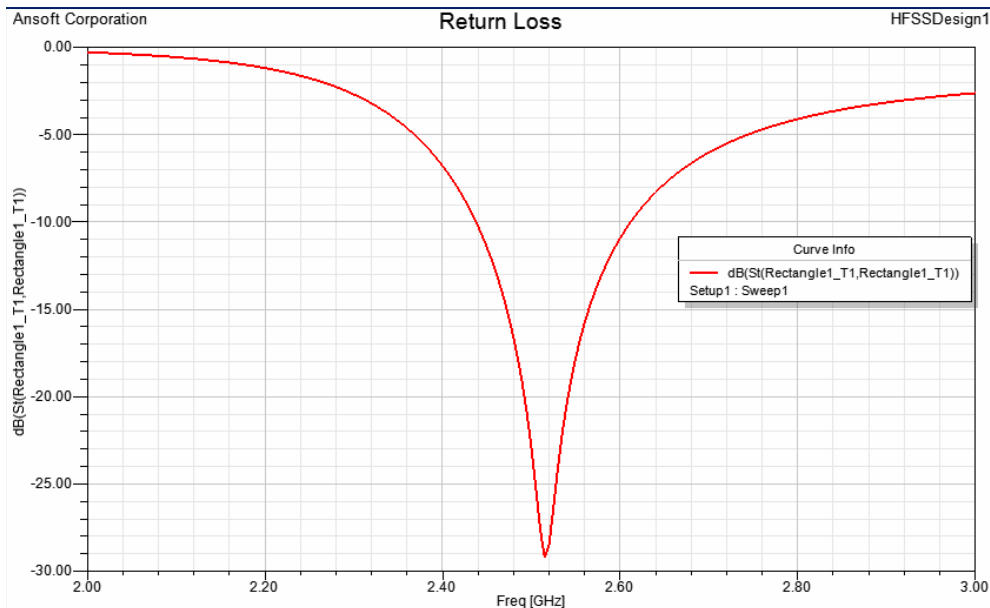
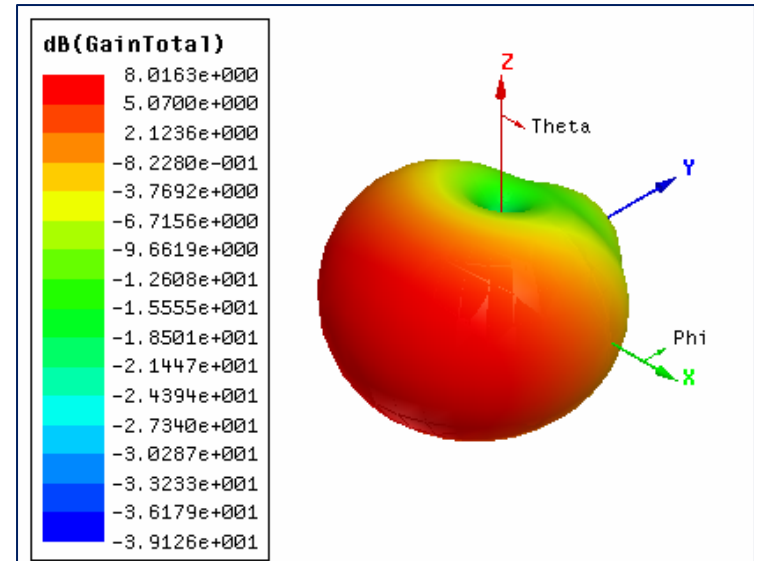

ACCESS  
IGN

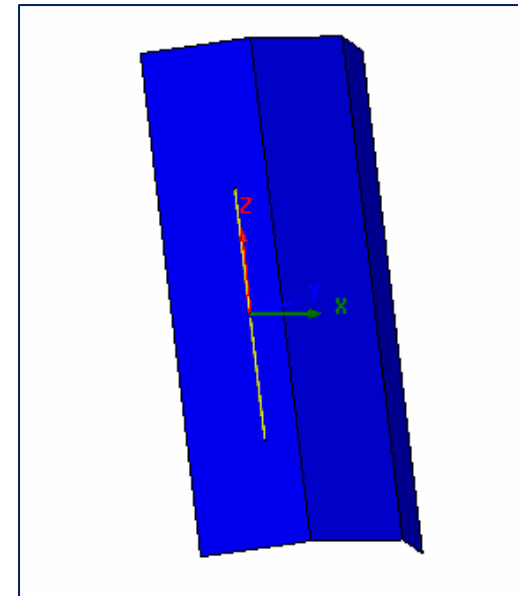

# Link Simulation

- Physical Channel
  - Antennas modeled
  - How to simulate link between?
- Utilize Ansoft HFSS Datalink
  - Fields from one drive another
  - Large separation without modeling air

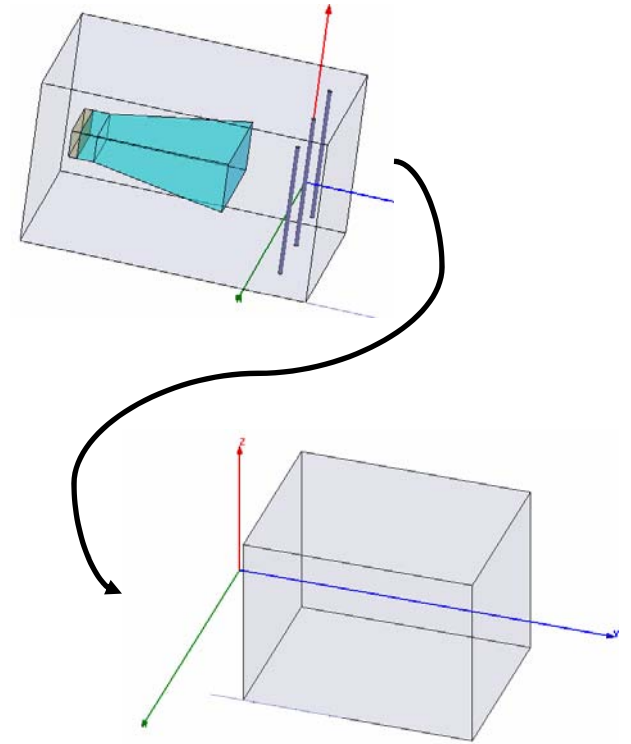

# HFSS Datalink

- Source Fields of Radiation Boundary
  - Imposed on target model with loss and phase

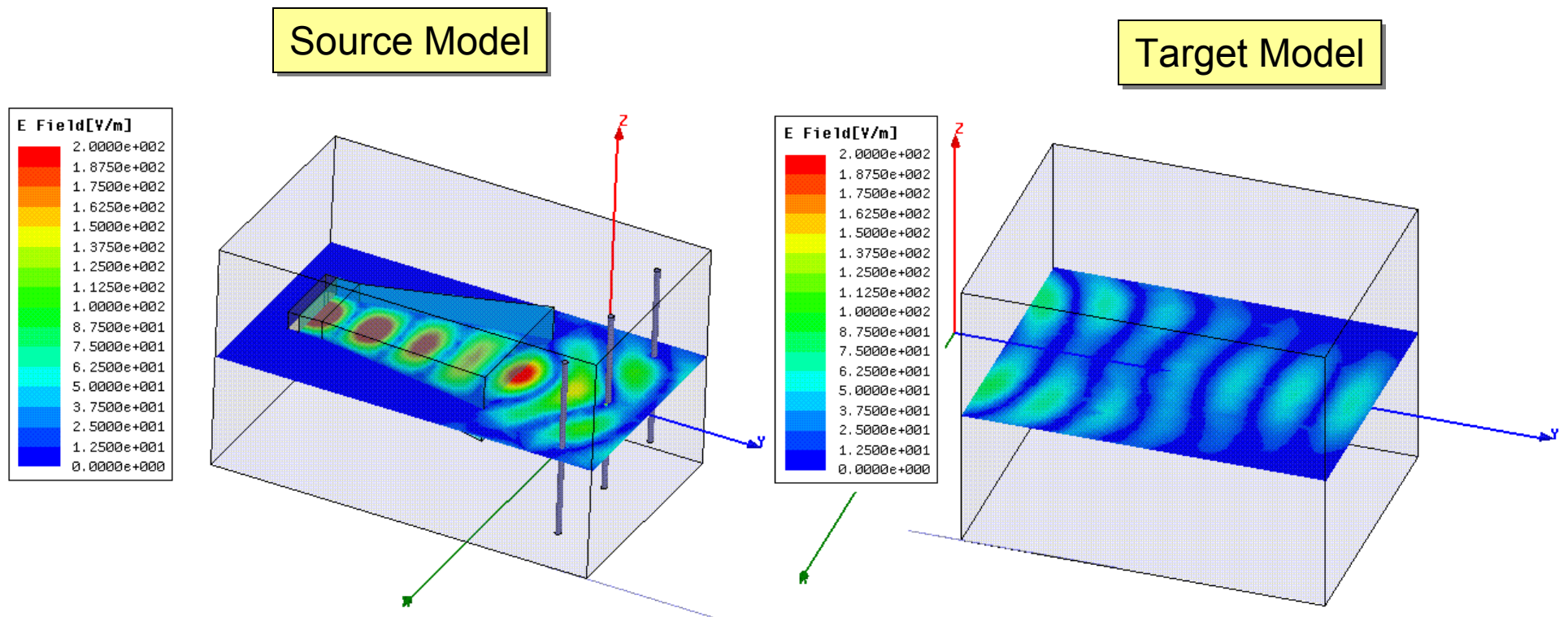

# MIMO Datalink

Fields from Source model radiation BC  
Mapped to target model using a Far Field  
Incident Wave

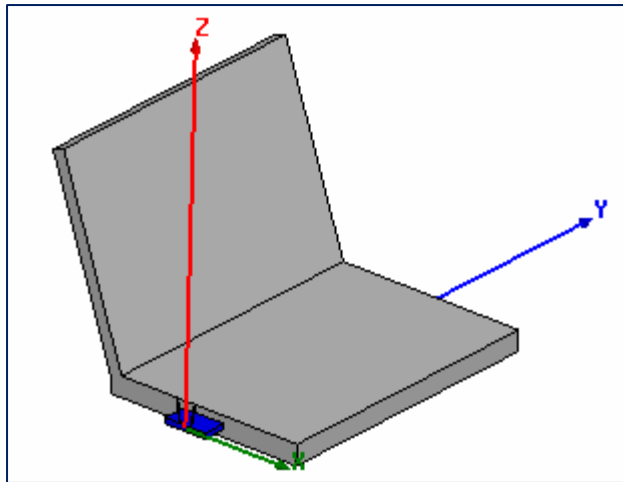

Laptop Model with Dual Monopoles

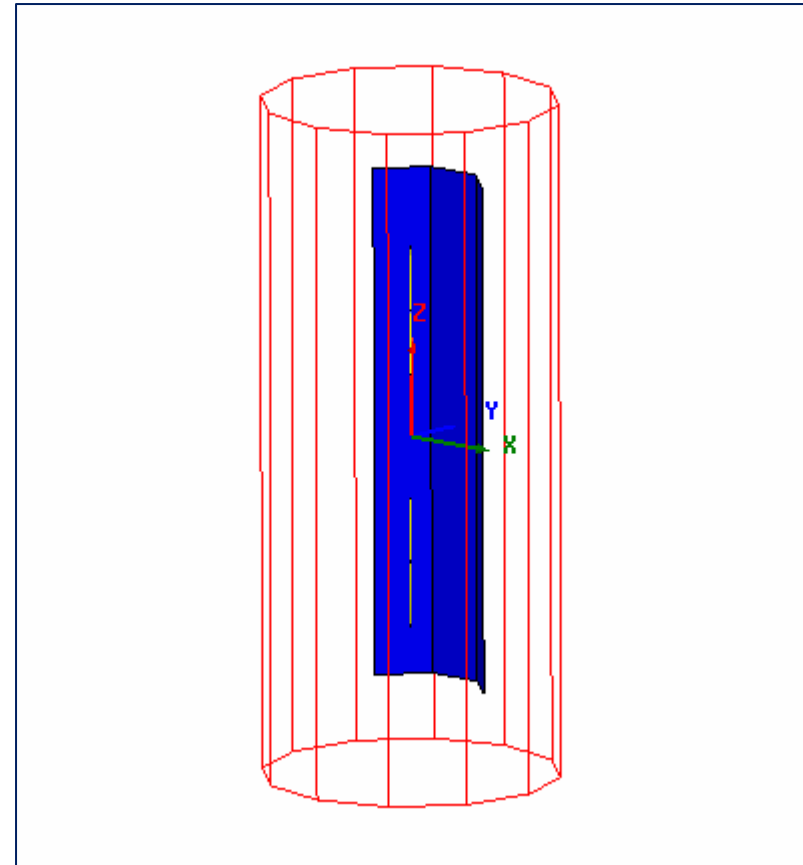

BS Model with Dual Dipoles and reflector



# MIMO Physical Channel Datalink

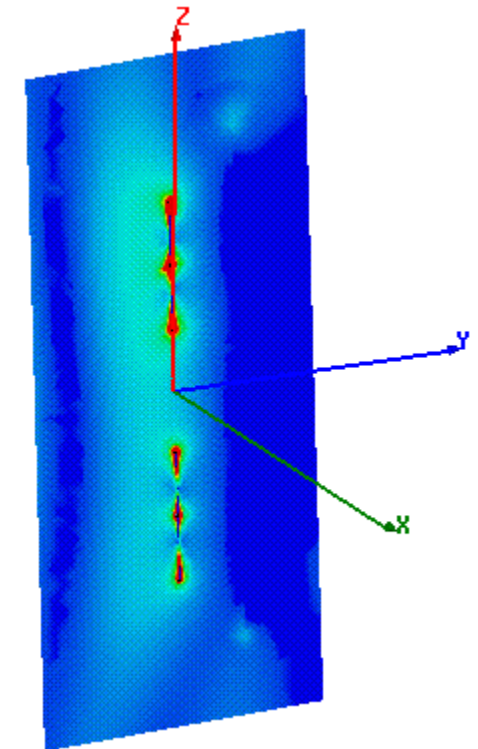
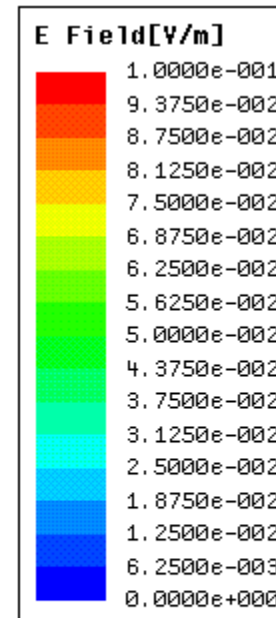
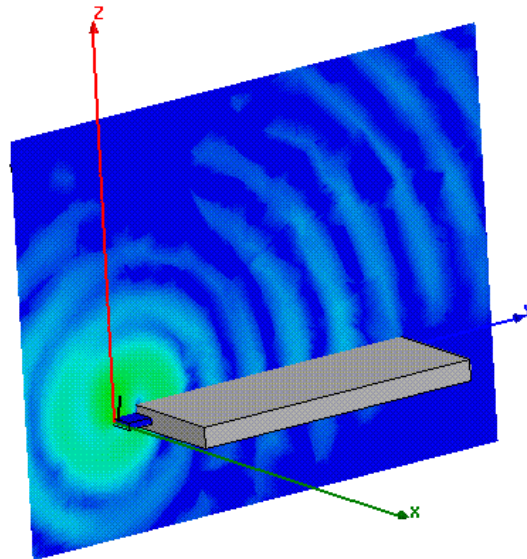
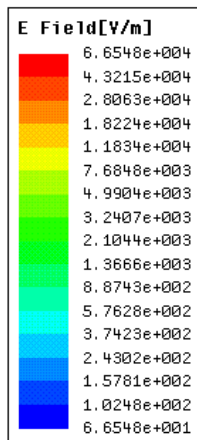

# MIMO Physical Channel Circuit Model

- HFSS-HFSS Datalink maps fields from a source volume to the target volume
- Q: How does this translate to a working circuit model ?
- A: Utilize the  $[Z]$  matrix in Nexxim
  1. Excite each antenna in system with a 1 A current source
  2. Using Datalink, measure O.C. voltage at all the other antennas
  3. Construct  $[Z]$  matrix from Voltages



# MIMO Physical Channel Circuit Model

- Voltage values extracted as real/imaginary pairs
- Assembled into  $[Z]$  matrix

$$Z_{ij} = \frac{V_i}{I_j} \Big|_{I_k=0, k \neq j}$$

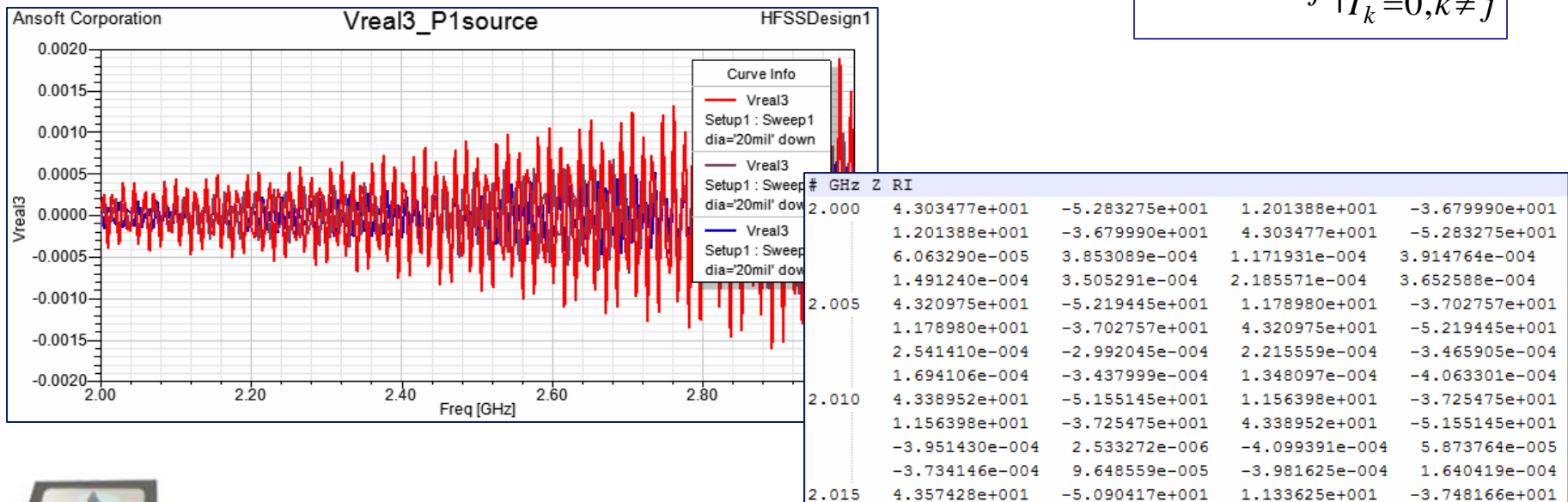

# WiMax Circuit Design

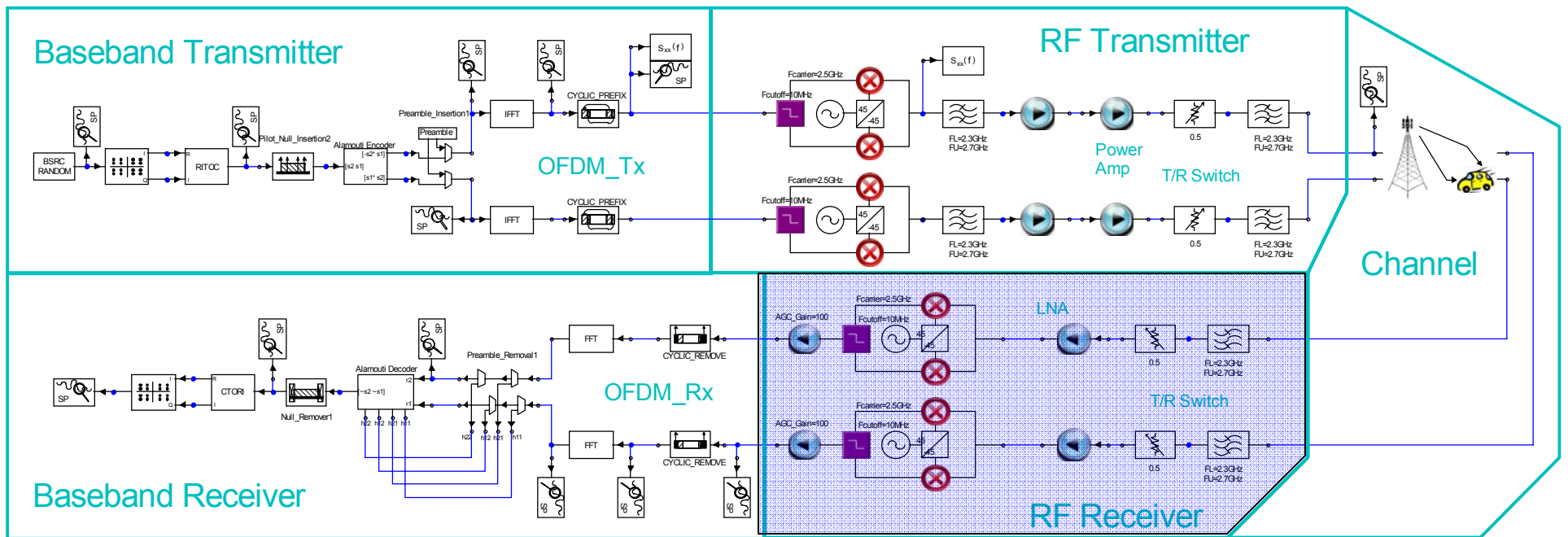

Circuit



# Antenna/Circuit Test Bench

- 2x2 MIMO Channel
- Dual Receiver
  - 2.5GHz to Baseband

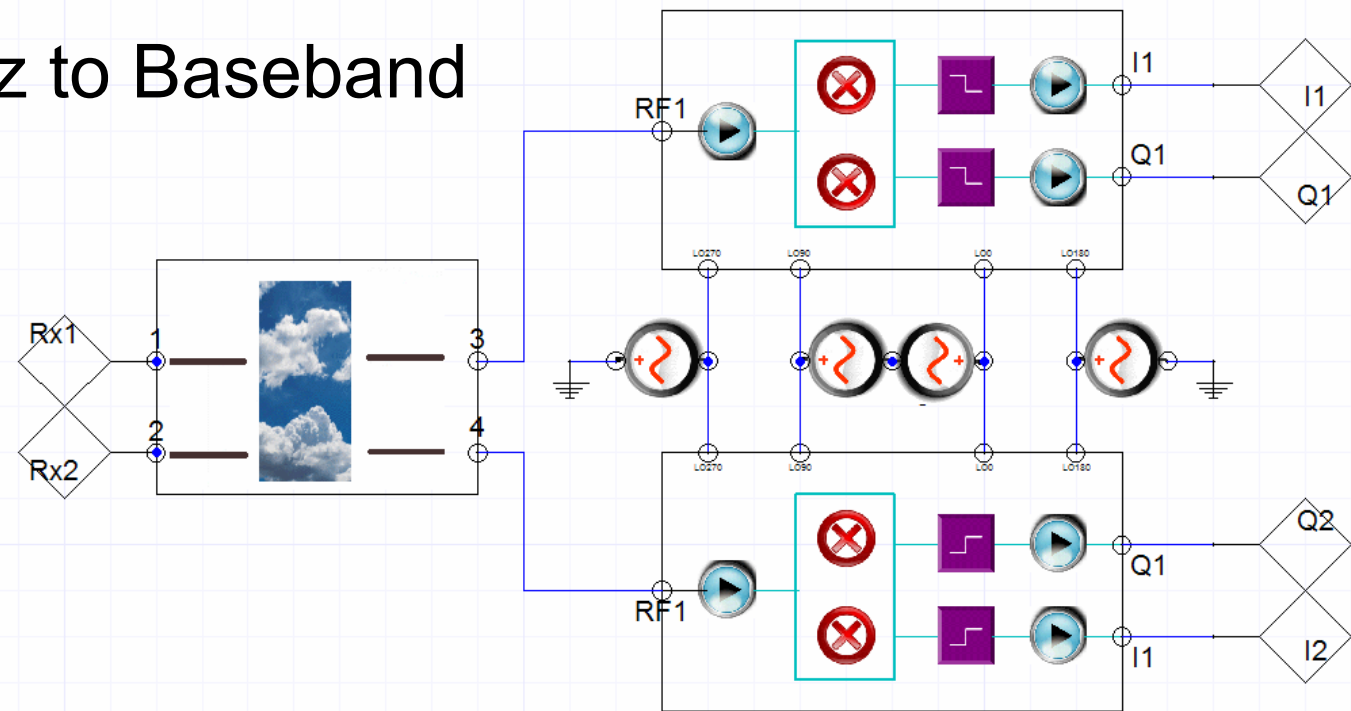

# WiMax Single RX Block Diagram

- Receiver per Antenna
  - Variable Gain LNA
  - Active Balun
  - IQ Mixer
  - Baseband Filter
  - AGC

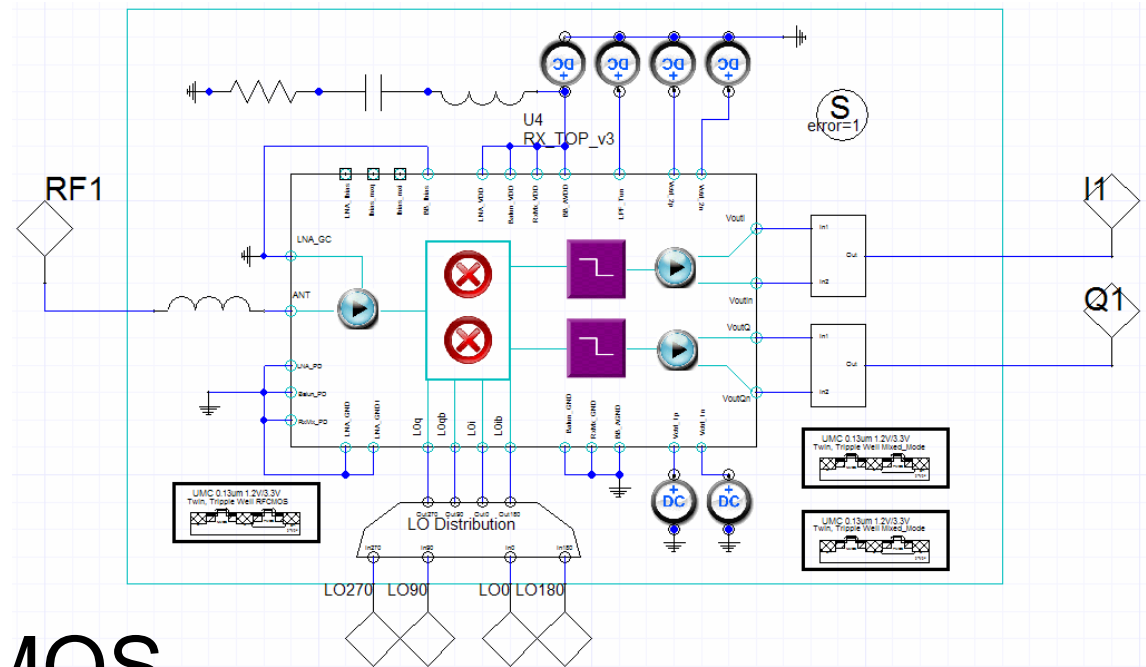

- UMC 0.13um CMOS



# WiMax Receiver

- Variable-Gain LNA
  - 2-stage, inductively-loaded cascode topology
  - output follower stage gain control.

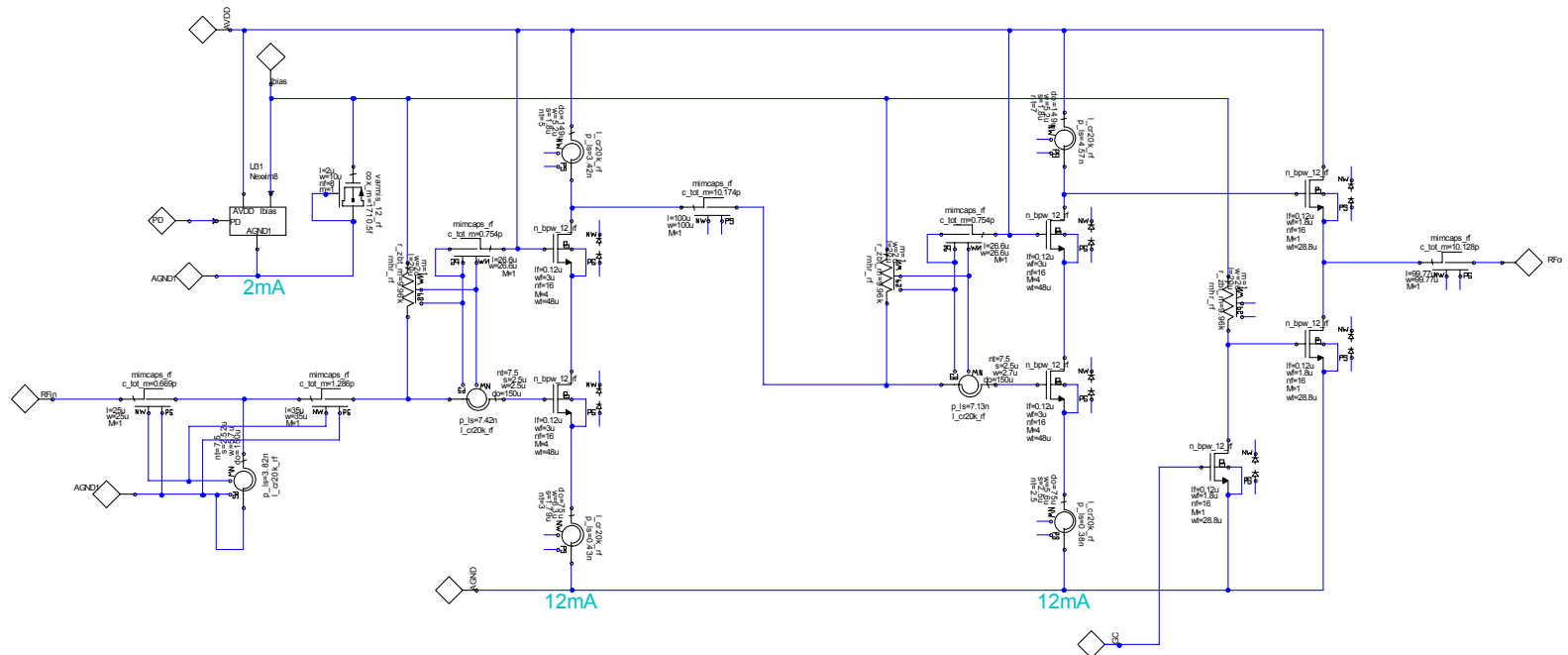

# WiMax Receiver

- I-Q Mixer
  - Dual, resistively-loaded Gilbert Cell cores
  - Folded RF feeds

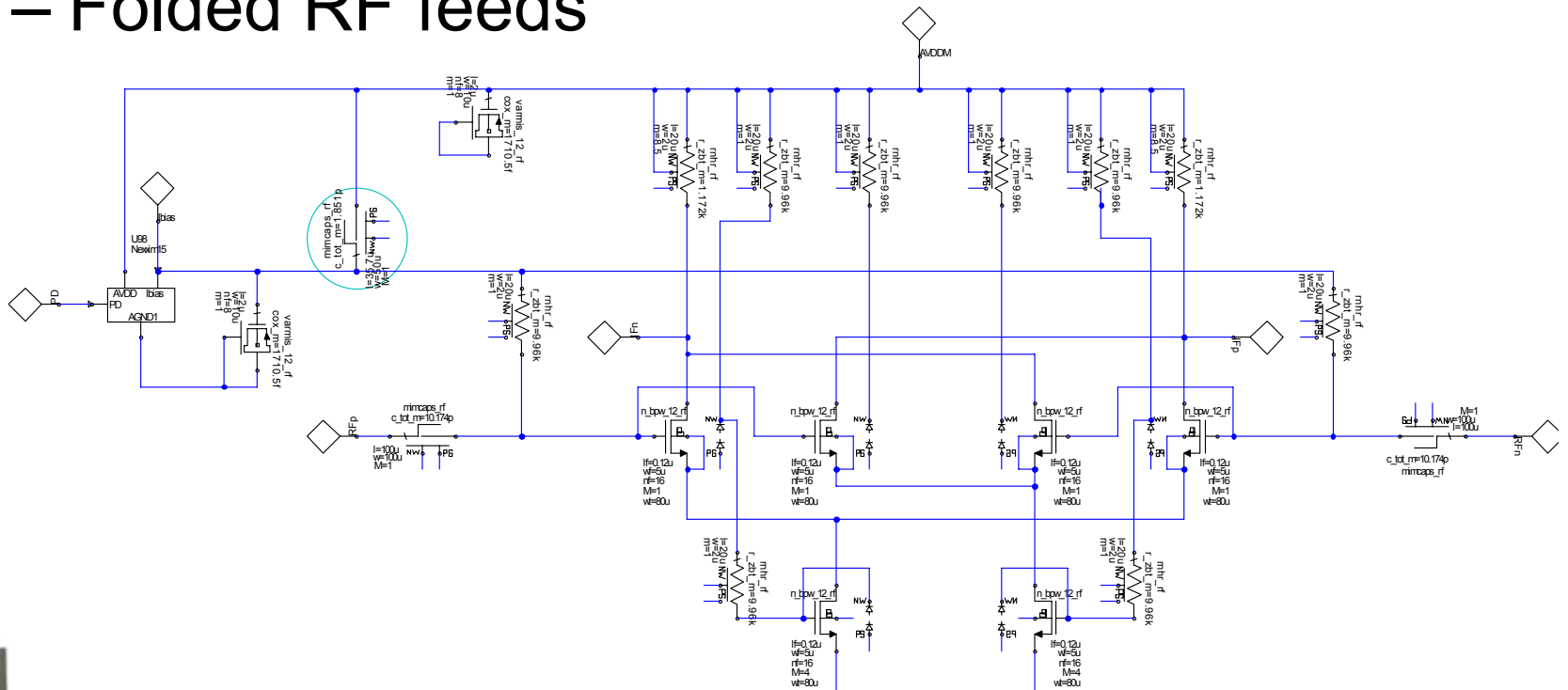

# WiMax Receiver

- Baseband Filter & AGC
  - Buffered active (gm-C)/passive bandpass
  - Integrated Automatic Gain Control.

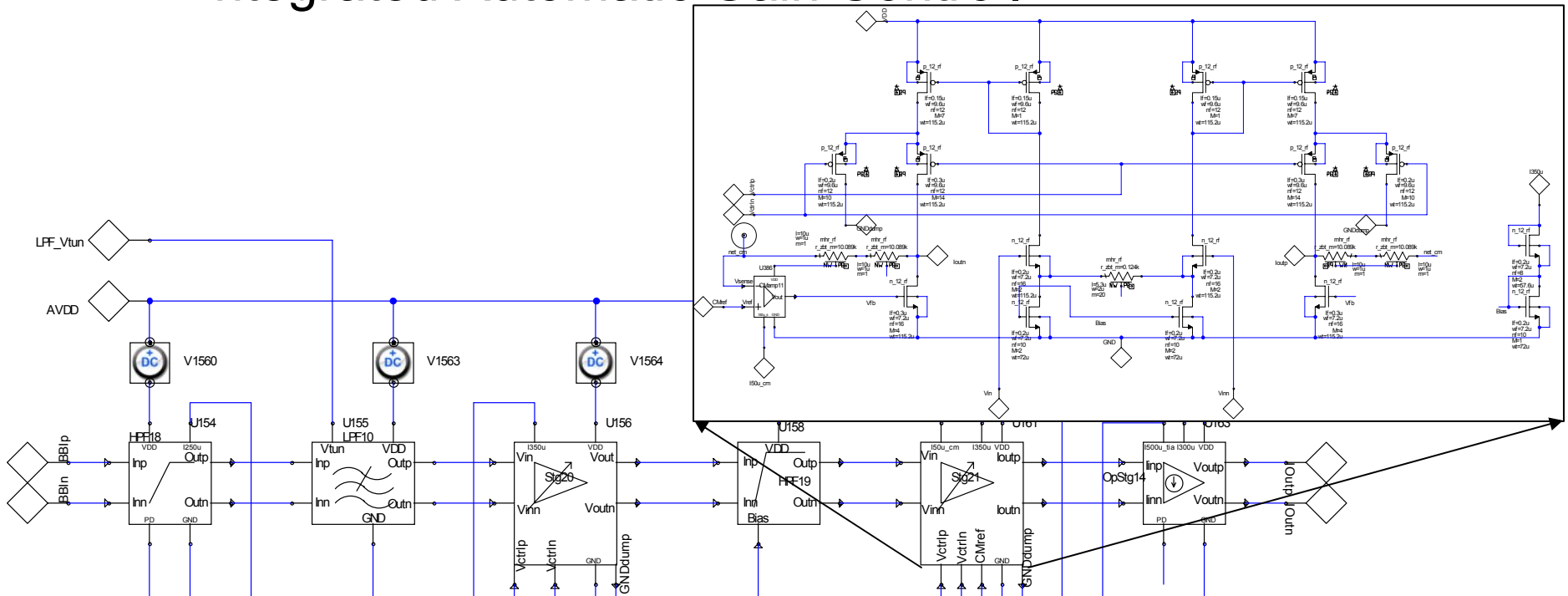

# WiMax RX Linearity Metrics

- Compression
  - Single RF & LO to baseband
- Third Order Intercept
  - Two RF & Single LO
  - Swept & Spectral Response

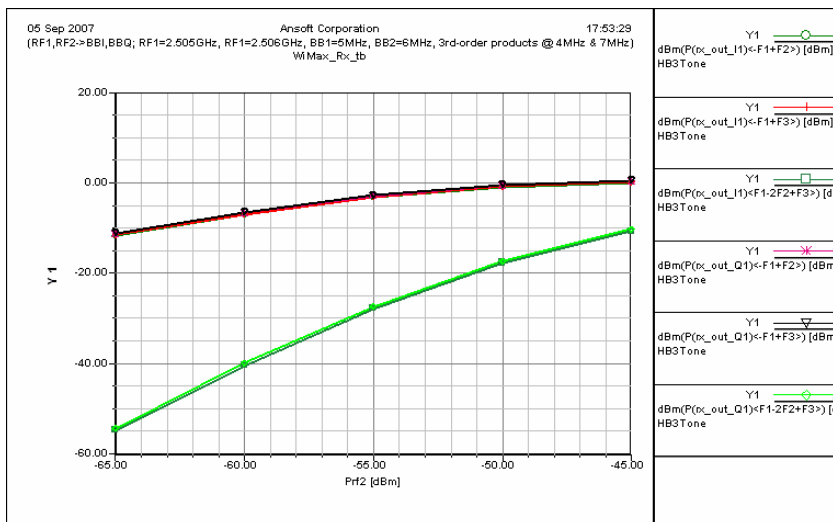
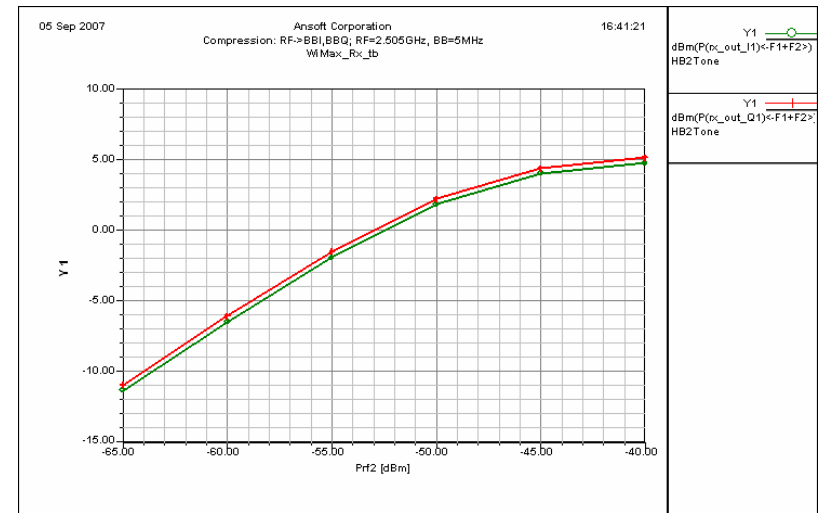

EM SUCC  
 ELECTRONIC DESIGN

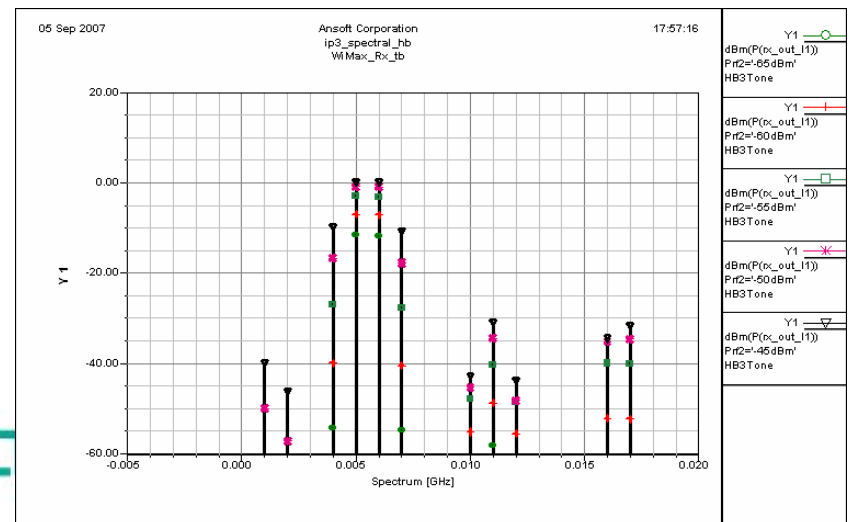

# Integration

Behavioral

Physical

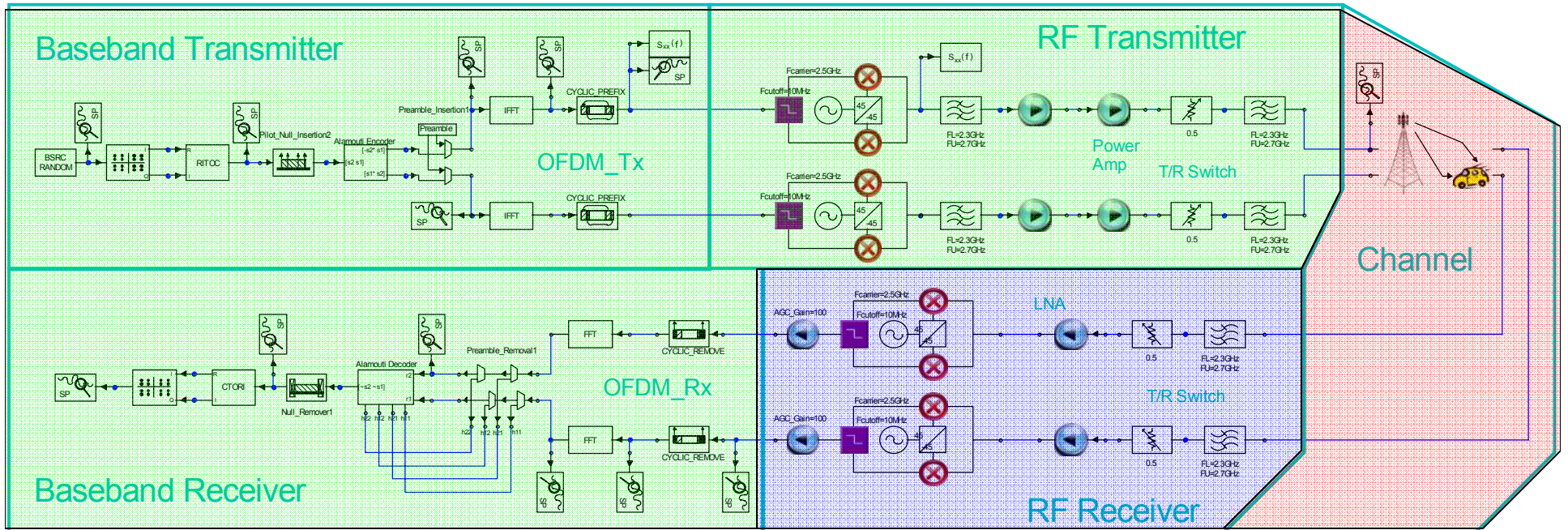

Circuit



# Complete WiMax System

- Baseband Tx/Rx
  - QAM, STC Encoder/Decoder, OFDM
- RF Tx/Rx
  - Quadrature Mixing, Amplification, Filtering
- Channel
  - SISO & MIMO, Link, Noise

Behavioral

Circuit + Behavioral

Physical

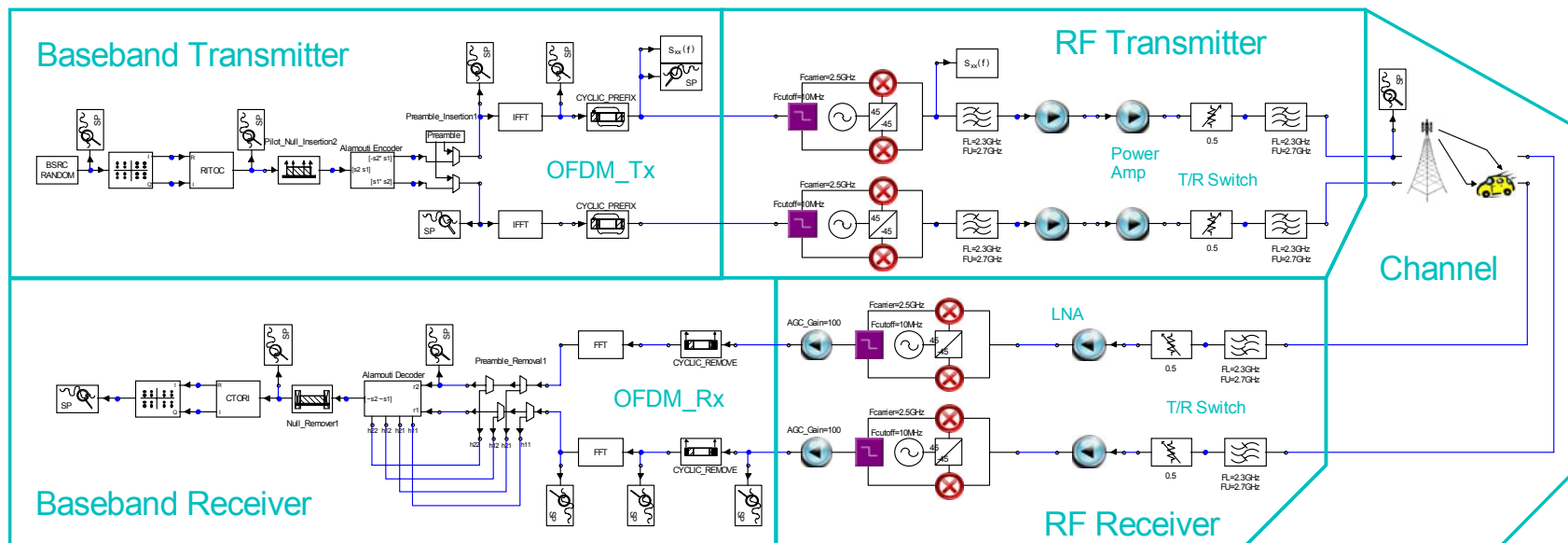

# Complete WiMax System

- Behavioral and Physical
  - SISO vs MIMO (Diversity gain)
  - EVM Distortion
- Circuit and Physical
  - Nonlinear interactions
  - Loading effects
- Behavioral, Physical and Circuit
  - BER distortion
  - Multipath degradation

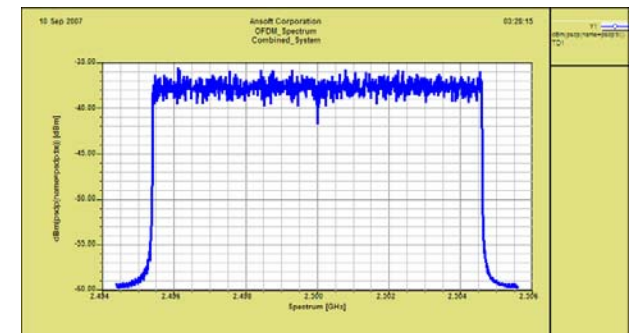
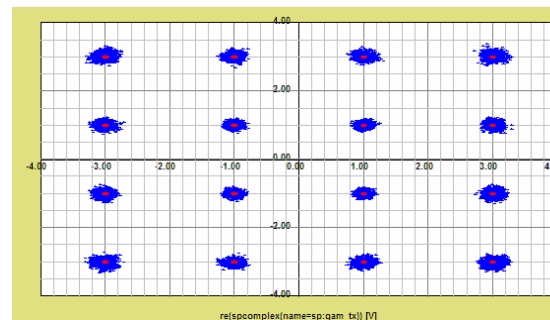
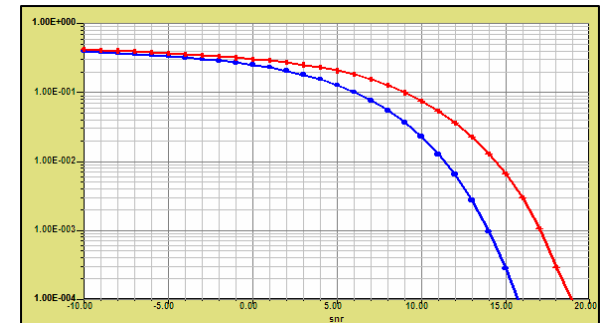

# Conclusion

- WiMax System Modeling
  - HFSS dynamic link for Channel
  - Nexxim for NL circuit impact
  - ***Unique Integration*** of Physical, Circuit & Behavioral
- HFSS, Nexxim & Designer together help you pave the way for:

**First Pass System Success**



# References

- [1] IEEE Std 802.16-14 Air Interface for Fixed Broadband Wireless Access Systems
- [2] IEEE Std 802.16e-2005 Air Interface for Fixed Broadband Wireless Access Systems
- [3] Mobile WiMax – Part I: A Technical Overview and Performance Evaluation
  - WiMax Forum
- [4] MIMO System Technology for Wireless Communications
  - By George Tsoulos
- [5] Digital Communications by Bernard Sklar
- [6] OFDM for Wireless Multimedia Communications
  - by Richard van Nee and Ramjee Prasad, Artech House Publishers
- [7] The suitability of OFDM as a modulation technique for wireless telecommunications, with a CDMA comparison
  - by Eric Lawrey, October 1997
- [8] Modeling an Advance Communication System based on OFDM
  - By Eldon Staggs, September 2000

