

ANSOFT'S HFSS USERS PRESENTATIONS

21st FEBRUARY, 2003

Los Angeles, CA; Crowne Plaza Hotel, LA International Airport

TITLE

**ANTENNA DESIGN AND VALIDATION WITH
ANSOFT'S HIGH FREQUENCY SIMULATOR (HFSS)**

PRESENTED

BY

AMEDEO LARUSSI

ANSOFT'S HFSS USERS PRESENTATIONS

**SPECIAL THANKS TO RAYTHEON AND DATRON FOR
PERMISSION TO SHOW THE ENCLOSED MODELS**

Raytheon

Space and Airborne Systems

EW Systems, Goleta, CA

Titan Corporation

Datron Advanced Technologies Division

Simi Valley, CA (Formerly Datron/Transco INC.)

The Company's industry-leading technology is based on more than 30 years of experience in designing and developing satellite tracking antenna systems for the U.S. military and commercial applications. The Company has expanded its communication solutions to include remote sensing satellite ground stations, mobile broadband communication systems for airlines and military transports.

EXAMPLE OF RAYTHEON EW PRODUCTS

Raytheon

Space and Airborne Systems
Electronic Warfare Systems

Integrated EW Systems



ECM pods and integrated systems for current and future airborne/shipboard platforms



ALQ-184 and ALQ-184(V)9 Pods



ALR-69 RWR Upgrade



SLQ-32 ESM/ECM



UCAV/UAV ESM/EA

Titan Corporation
Datron Advanced Technologies Division

EXAMPLE OF DATRON PRODUCTS



Datron's systems deliver the vital up and down link services for advanced data communications. Easily configured for specialized missions, we offer antenna systems for Telemetry, Tracking and Control (TT&C), satellite communications (SATCOM), Remote Sensing Satellite (RSS) and Telemetry applications.

The Datron Series 1302 L/S-Band is a state-of-the-art telemetry autotracking antenna system for high velocity sources. Constructed of standard, off-the-shelf Datron products, the Series 1302 receives telemetry data from RF sources radiating in the 1.435 to 1.540 GHz, 1.670 to 1.850 GHz and 2.200 to 2.400 GHz bands. Designed to withstand harsh environmental conditions, this system is also easily adapted to mobile and transportable configurations.

NUMERICAL TECHNIQUES IN ELECTROMAGNETIC ENGINEERING A BRIEF COMMENTARY

THREE BASICS METHODS:

- Method of Moments (R. F. Harrington, 1968)
- Finite Difference (K. S. Yee, 1966)
- Finite Elements (P. P. Silvester, 1969)

OTHER TECHNIQUES:

-UTD, Mode Matching, etc.

EXAMPLES OF ELECTROMAGNETIC SOLVERS USED TO CONDUCT THEORETICAL MODELING

- **GEMACS** (Air Force Research Laboratory-EXPORT CONTROLLED)
USES MOM/UTD/FD METHODS ALONE OR COMBINED.
- **NEC** (Lawrence Livermore National Laboratory)
MOMENT METHOD WIRE CODE
- **NEC-REFL** (The Ohio State University, Electroscience Lab.)
GTD/AI METHODS
- **ENSEMBLE** (Ansoft)
MOMENT METHOD
- **HFSS** (Ansoft)
FINITE ELEMENT METHOD

EXAMPLES OF FINITE ELEMENT METHOD ACCURACY (HFSS BY ANSOFT)

THEORETICAL VERSUS
MEASURED PERFORMANCE

Raytheon

Space and Airborne Systems

Electronic Warfare Systems

6380 Hollister Avenue

Goleta, CA 93117-3114

EXAMPLE NO 1
12 INCH CABLE MODEL PERFORMANCE (HFSS) VS
MEASURED DATA

12" CABLES MODEL (HFSS)
ONLY DIELECTRICS SHOWN

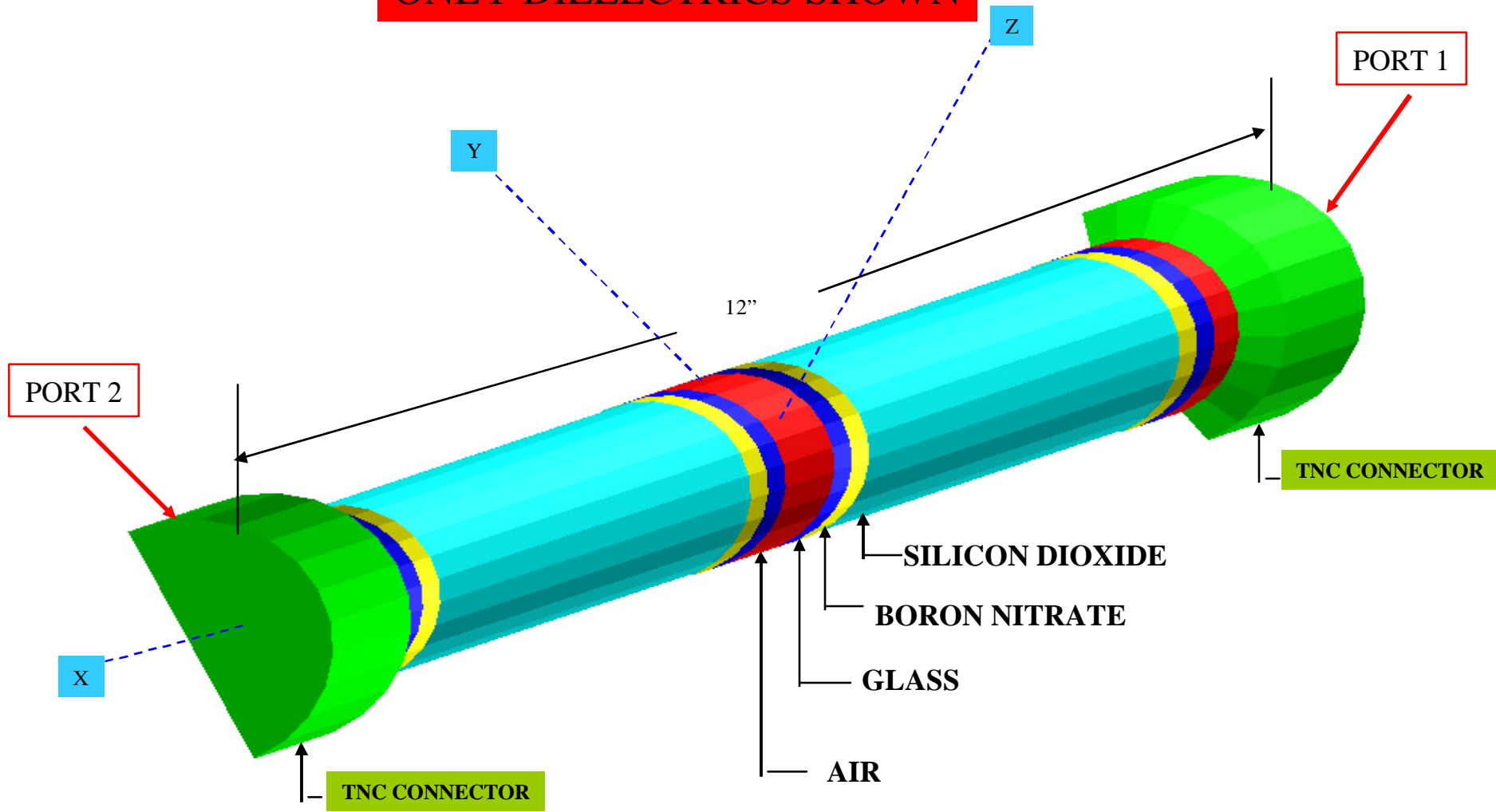

THEORETICAL vs MEASURED DATA FOR TWO 6" CABLE IN SERIES

— THEORETICAL (HFSS) - - - MEASURED DATA

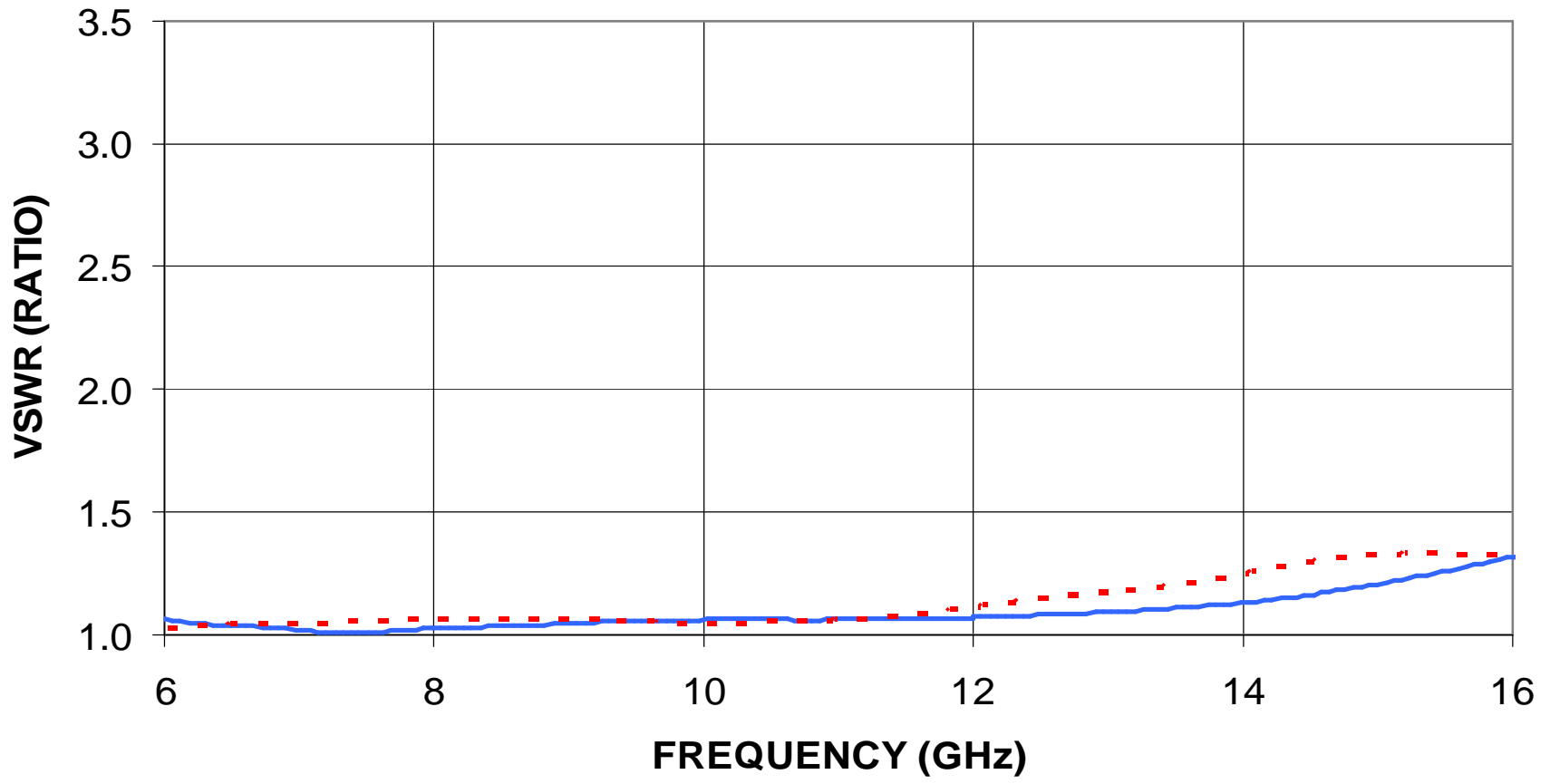

THEORETICAL (HFSS) vs MEASURED DATA OF TWO 6" CABLES (WITH TNC CONNECTORS) IN SERIES (12")

— THEORETICAL (HFSS 100 FREQUENCY POINTS) — MEASURED DATA (800 FREQUENCY POINTS)

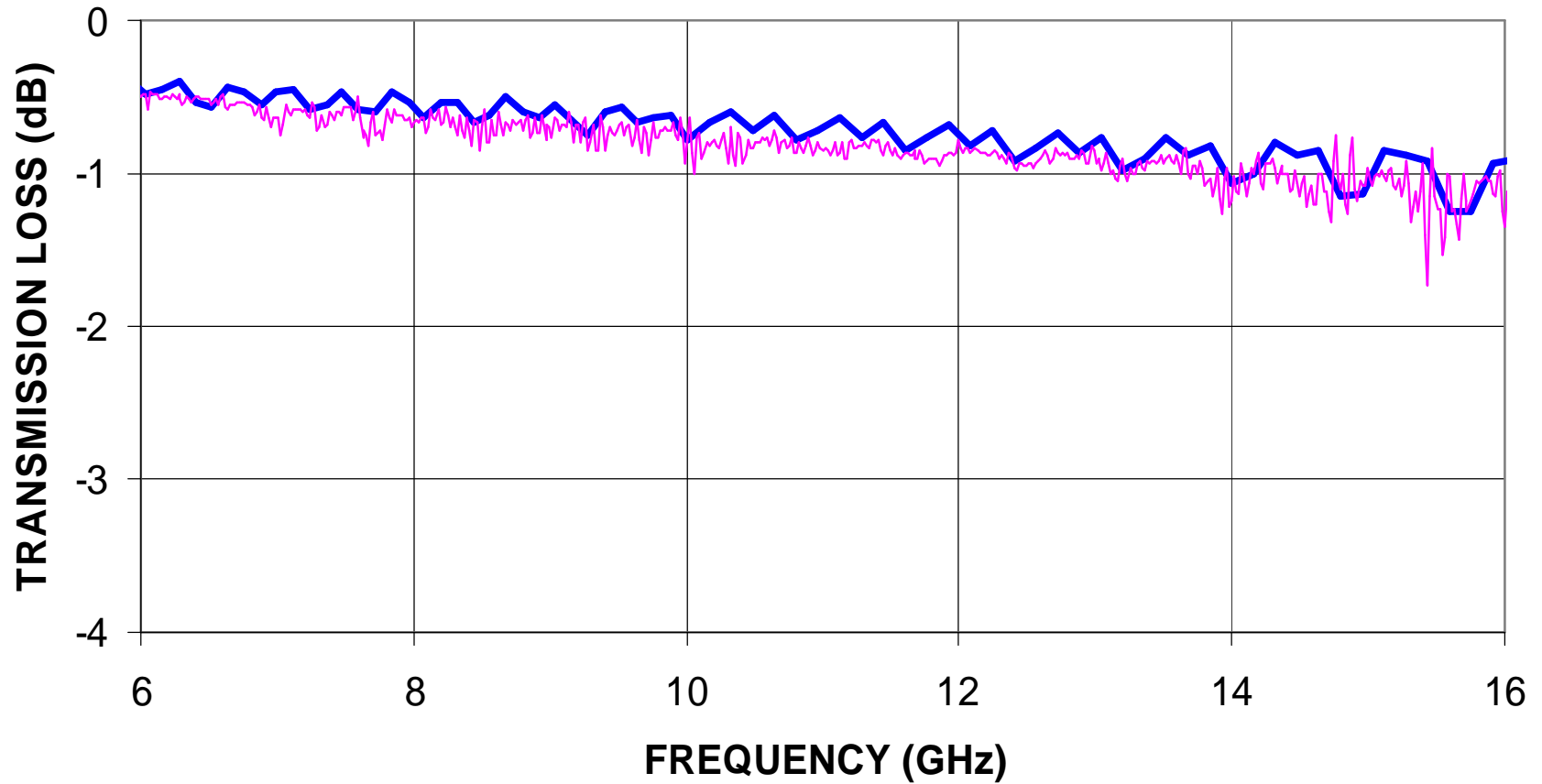

EXAMPLE NO. 2 (ANTENNA NOT SHOWN)
THEORETICAL AND MEASURED RADIATION PATTERNS
PERFORMANCE OF AN ANTENNA, PLUS RADOME AND
CABLE.

THEORETICAL (HFSS) vs MEASURED DATA OF A ANTENNA AT 8 GHz

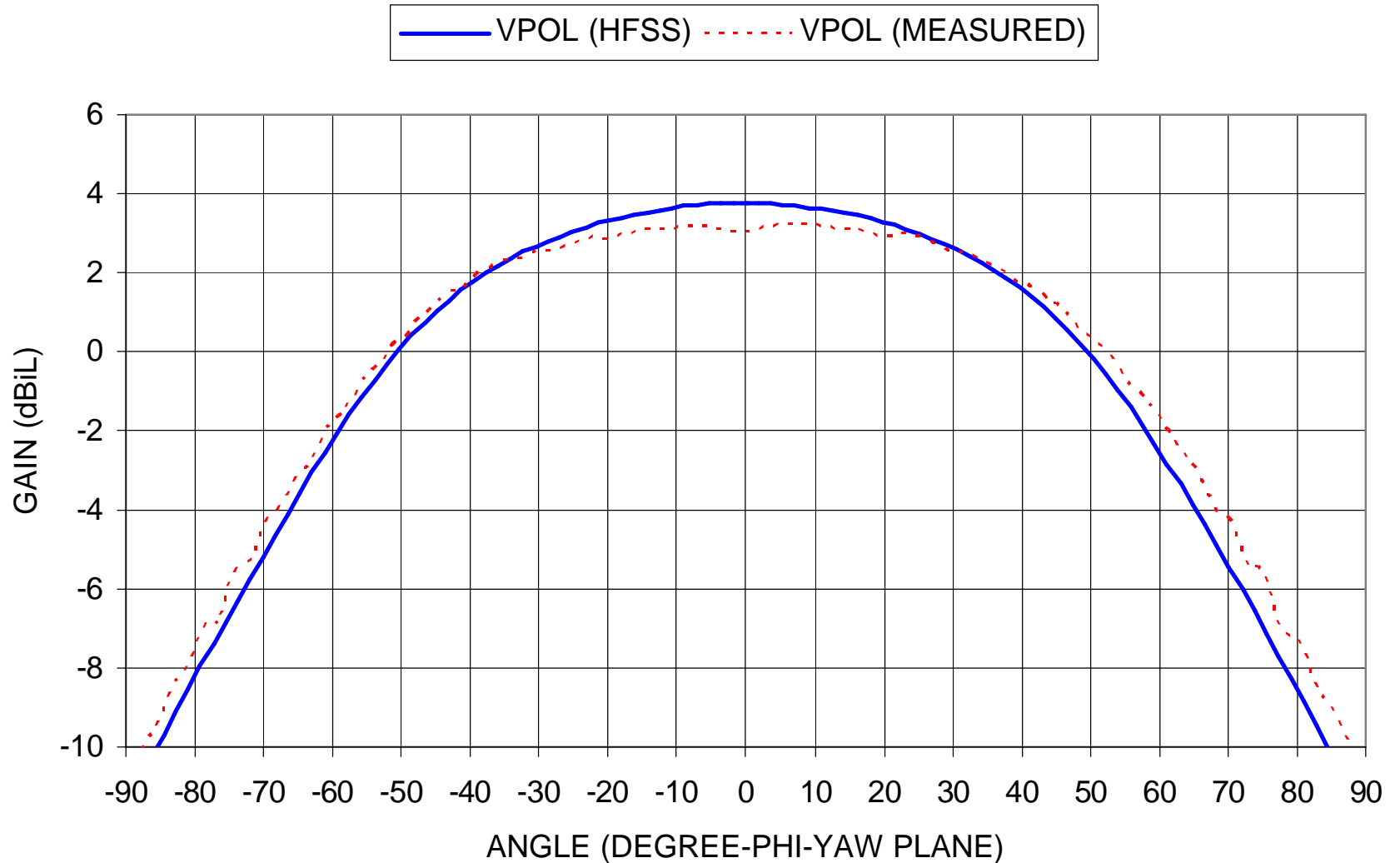

THEORETICAL (HFSS) vs MEASURED DATA OF A ANTENNA AT 8 GHZ

— HPOL (HFSS) - - - HPOL (MEASURED)

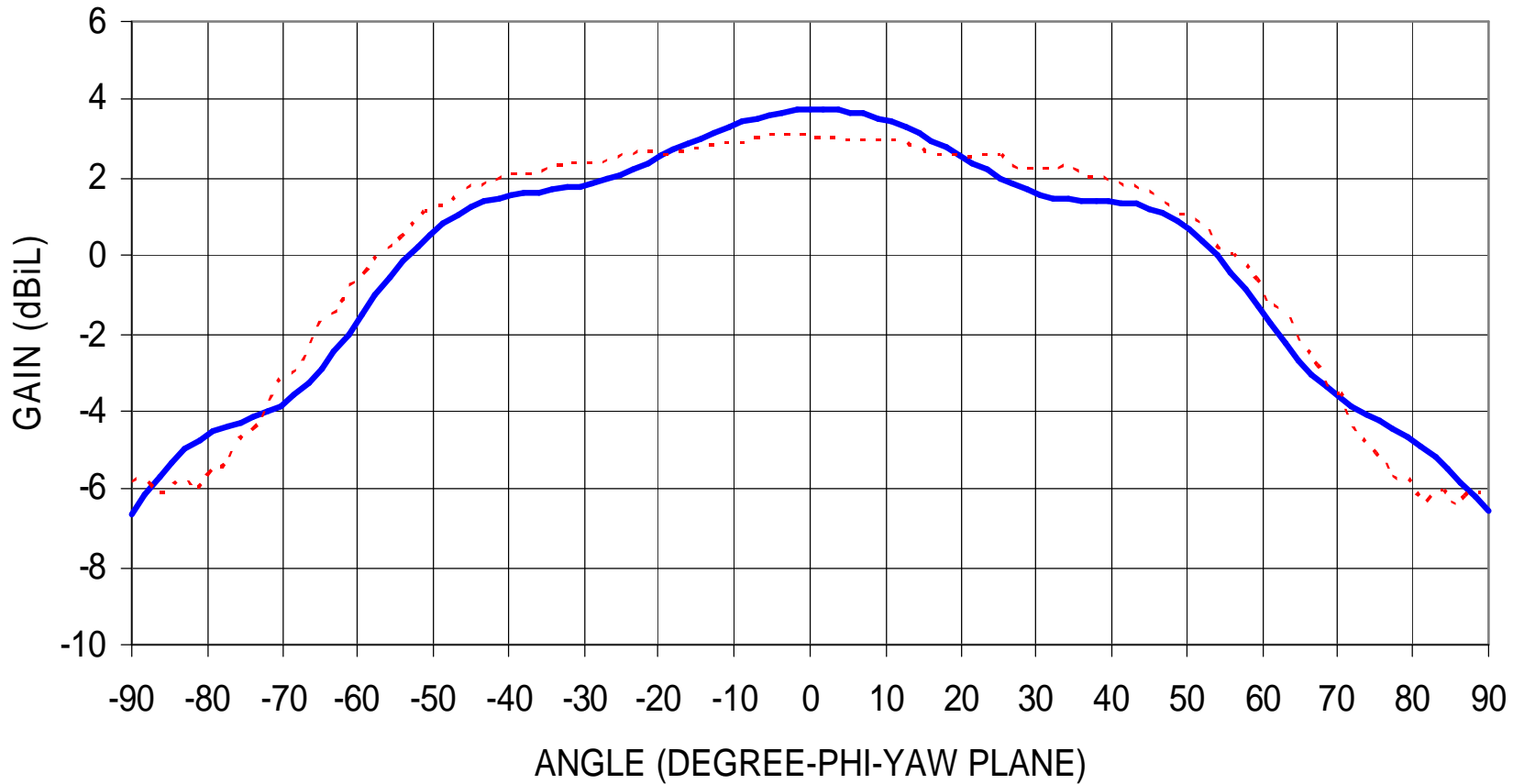

THEORETICAL vs MEASURED DATA OF A ANTENNA AT 11 GHz

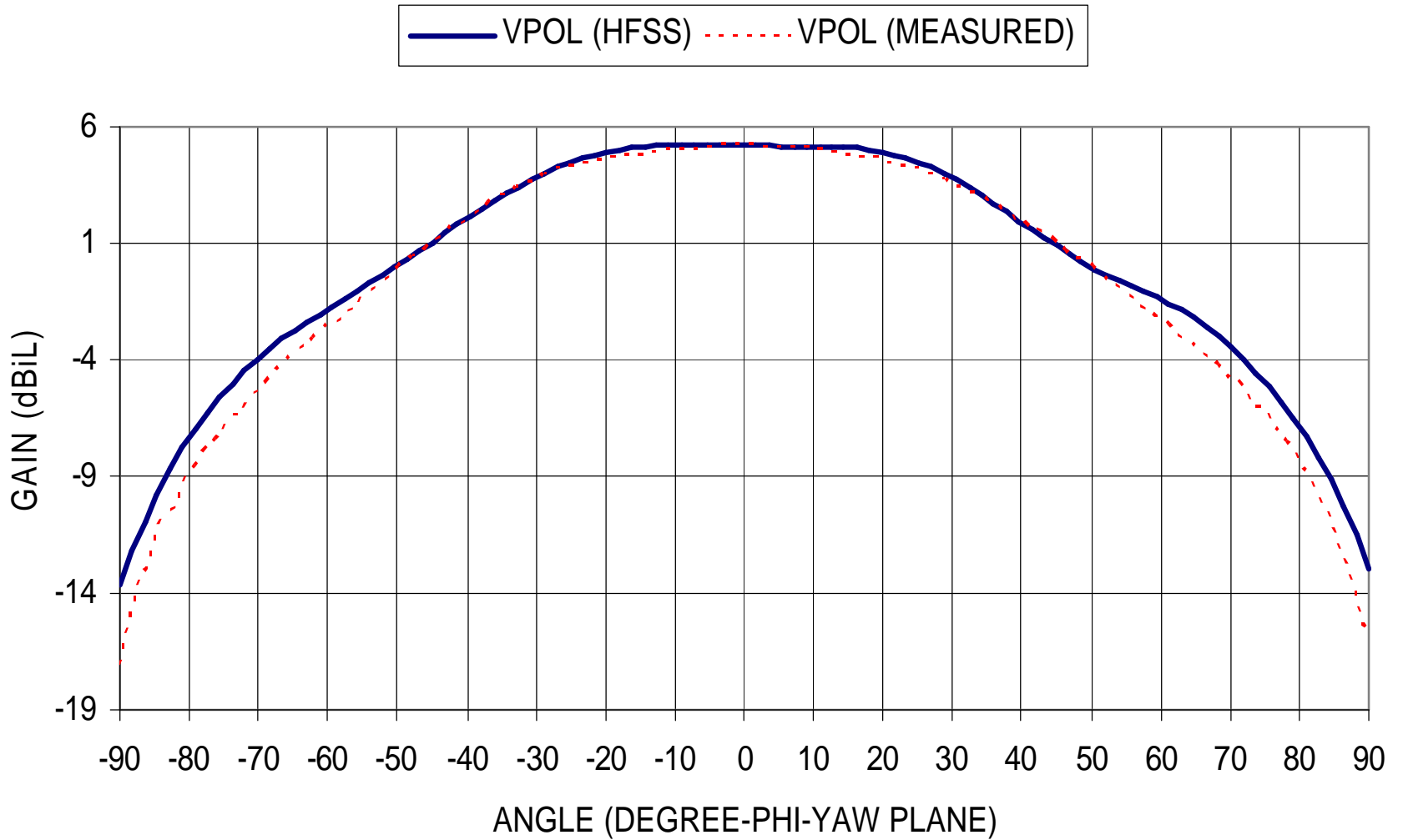

THEORETICAL vs MEASURED DATA OF A ANTENNA AT 11 GHZ

— HPOL (HFSS) - - - HPOL (MEASURED)

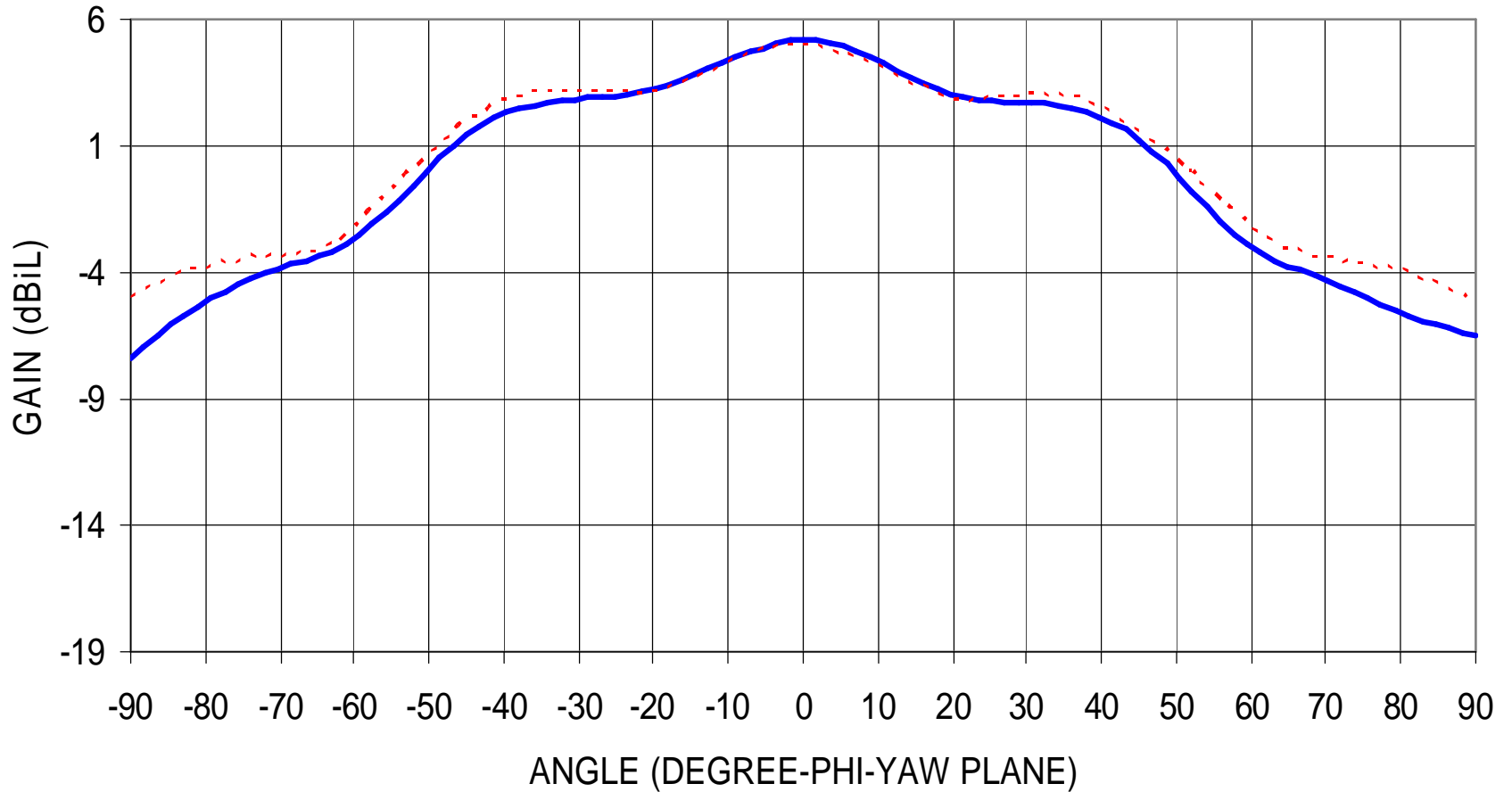

THEORETICAL (HFSS) vs MEASURED DATA OF A ANTENNA AT 16 GHz

— VPOL (HFSS) - - - VPOL (MEASURED)

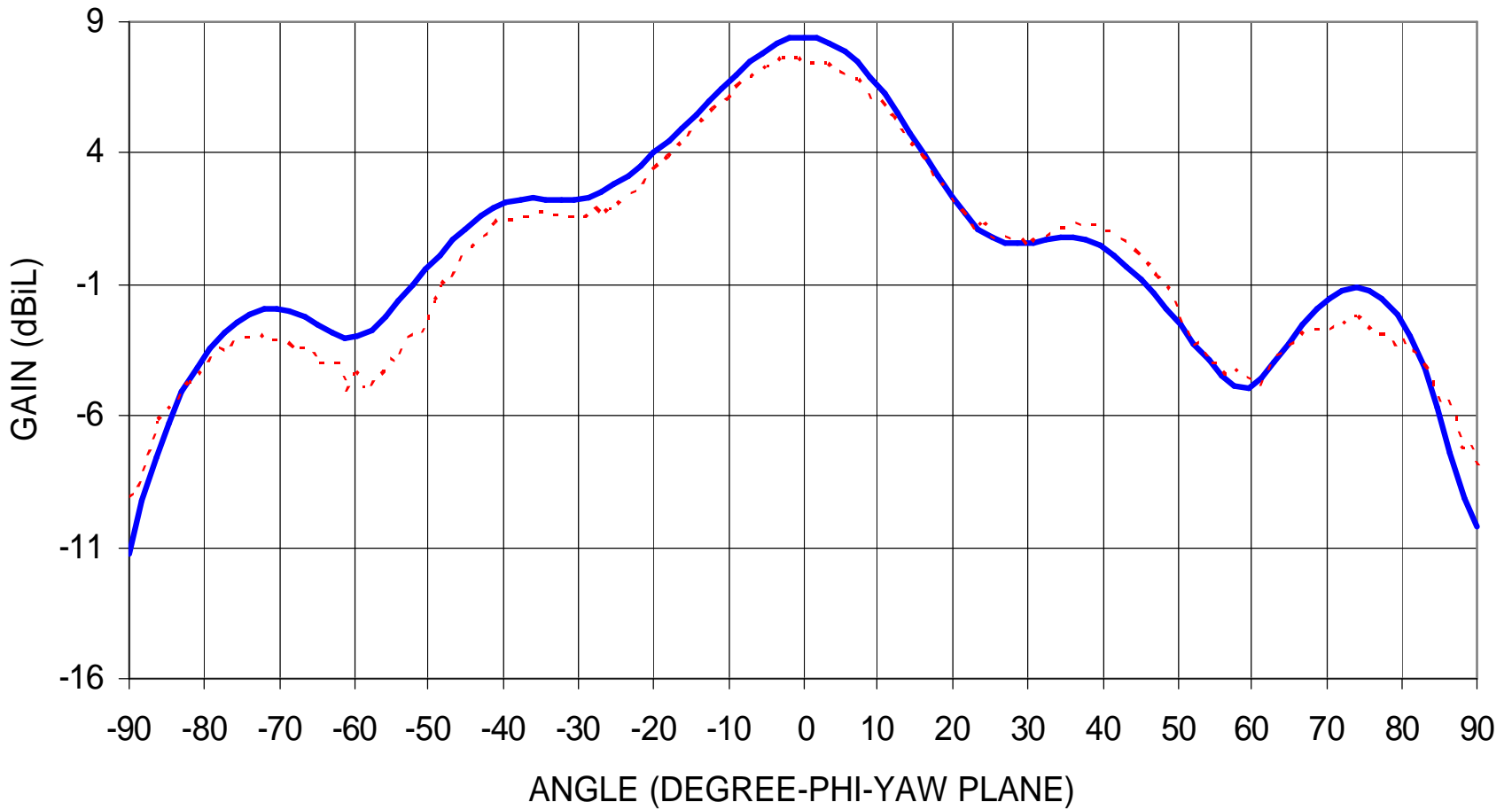

THEORETICAL (HFSS) vs MEASURED DATA OF A ANTENNA AT 16 GHz

— HPOL (HFSS) - - - HPOL (MEASURED)

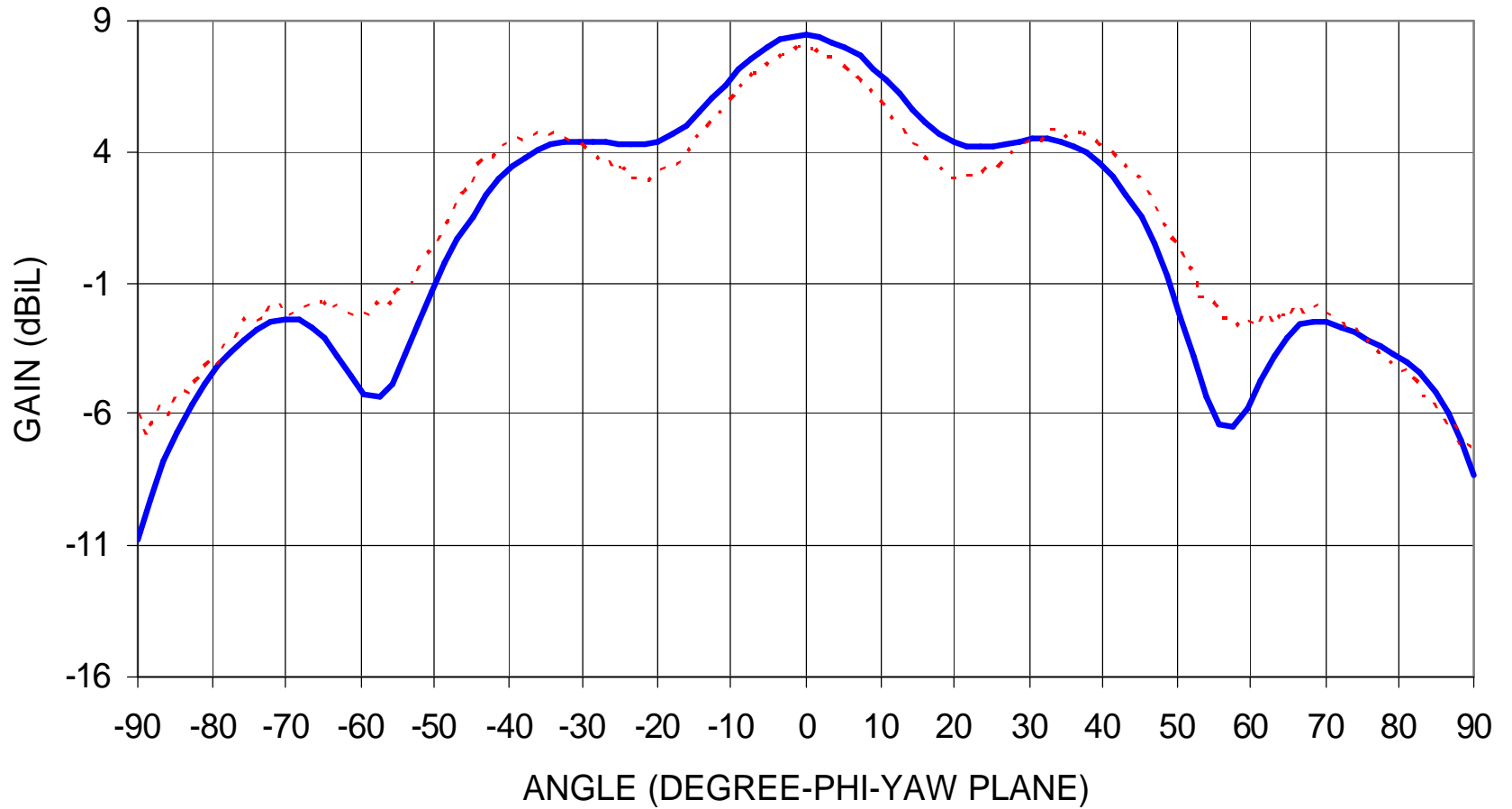

EXAMPLE NO 3
A DUAL RIDGE WAVEGUIDE STRUCTURE
MODEL

CABLE PLUS WAVEGUIDE SECTION MODEL (MODEL WAS SOLVED AS A VACUUM)

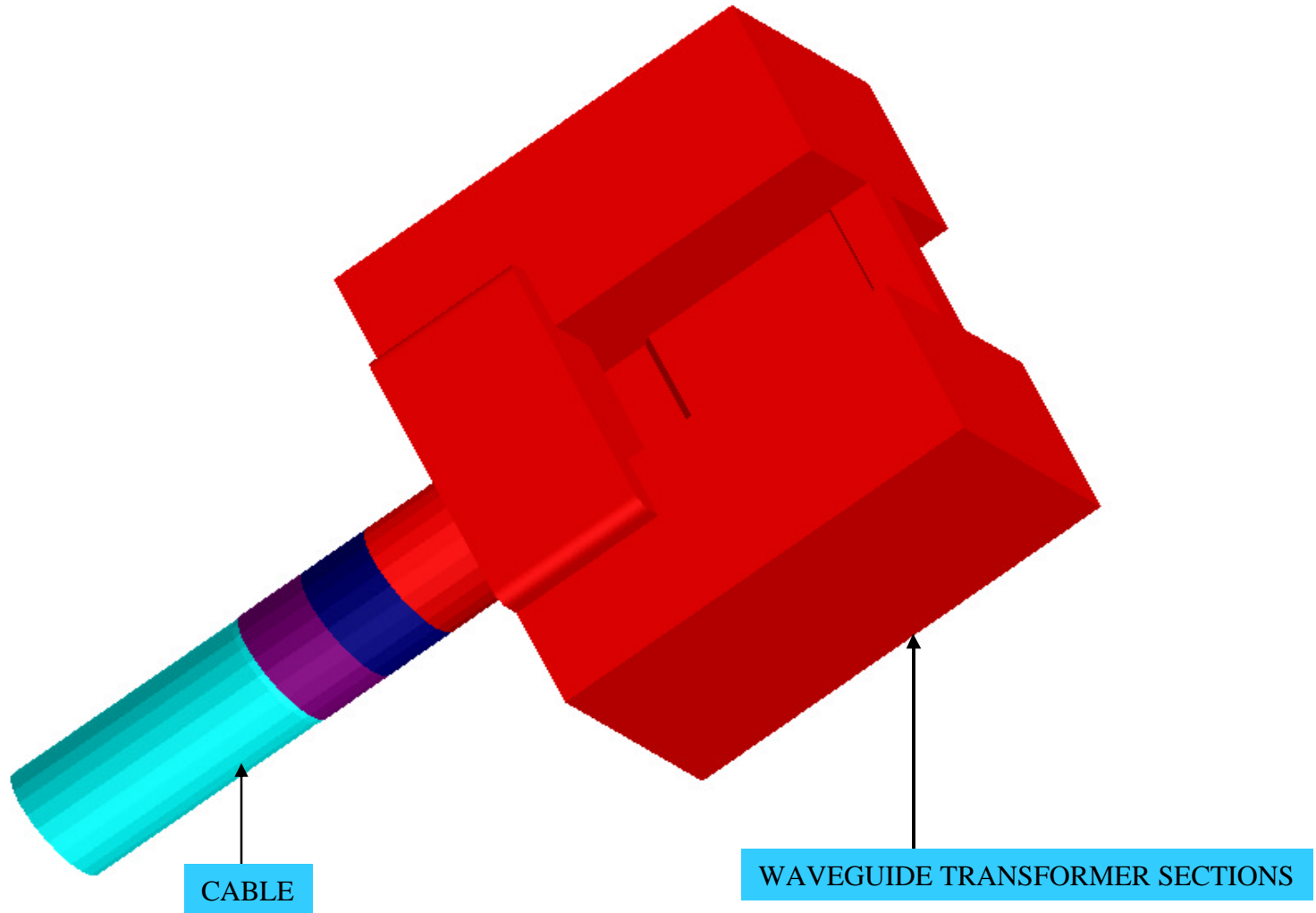

THEORETICAL (HFSS) VS MEASURED DATA OF A CABLE PLUS A DUAL RIDGE WAVEGUIDE STRUCTURE

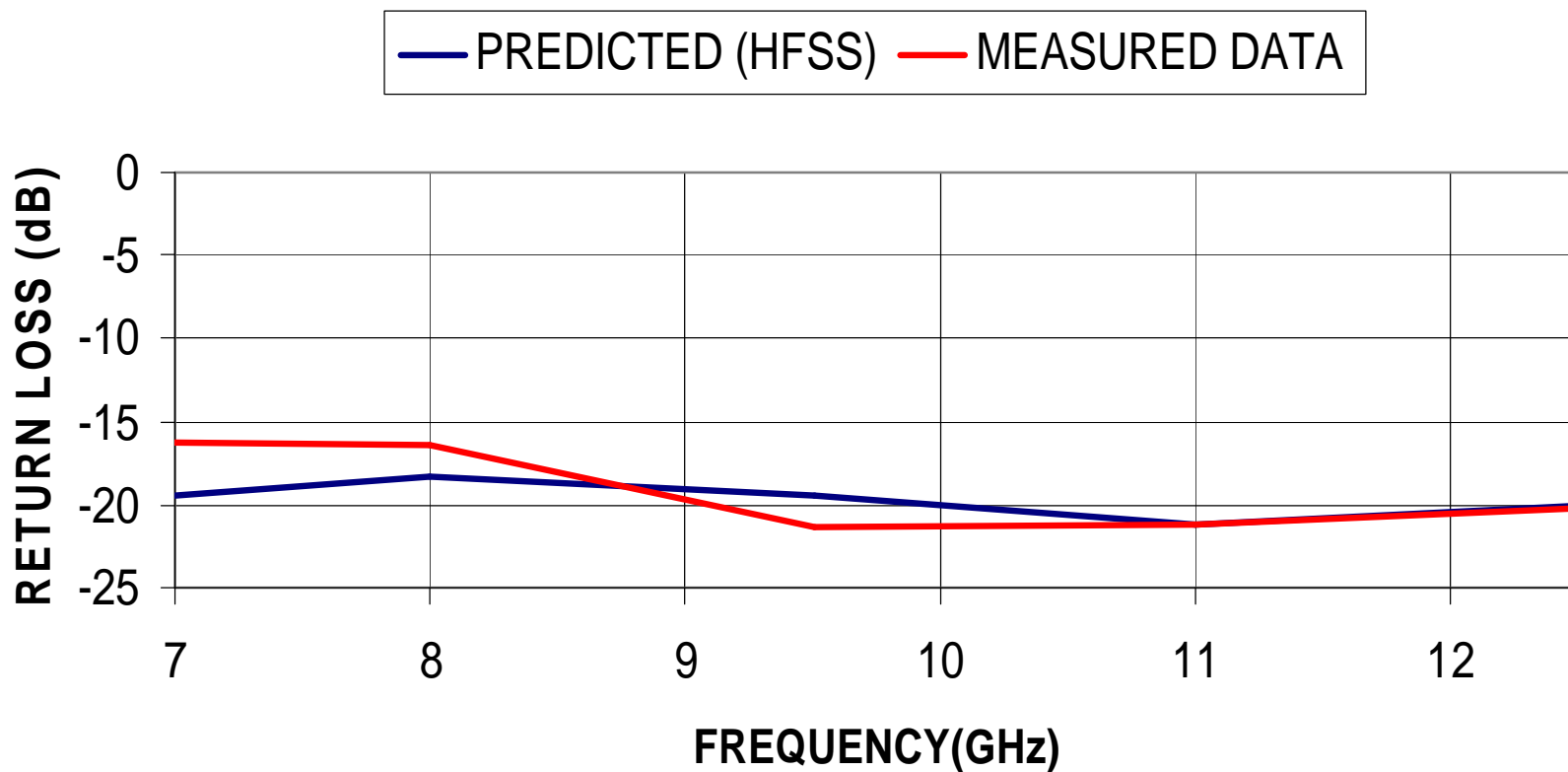

CIRCULAR WAVEGUIDE: EXAMPLE NO 4

TRADITIONAL APPROACH VS.
HFSS

TABLE 1 & 2 CAN BE DERIVED FROM:
 HELMHOLTZ EQUATION, TRANSVERSE LAPLACIAN, AND “SEPARATION OF VARIABLE METHOD”, A BESSEL DIFFERENTIAL EQUATION IS OBTAINED RESULTING IN TWO SOLUTION. ONLY ONE SOLUTION IS ACCEPTABLE. TABLE 1 & 2 IS THEN GENERATED AS SHOWN BELOW.

CIRCULAR WAVEGUIDES 32 MODES CUTOFF										
INPUT					UNITS CONVERSION					
DIAMETER=	0.7 IN INCHES				RADIUS=	0.01778 Meter				
TABLE VALUE FOR	λ CUTOFF									
	FOR TE _m n WAVES				TE CUTOFF WAVELENGTH				IN METER	
	m=	0	1	2	3	0	1	2	3	
n=	1	1.64	3.412	2.057	1.496	1	0.01458	0.030333	0.018287	0.013299
	2	0.896	1.178	0.937	0.764	2	0.007965	0.010472	0.00833	0.006792
	3	0.618	0.736	0.631	0.554	3	0.005494	0.006543	0.00561	0.004925
	4	0.475	0.54	0.48	0.44	4	0.004223	0.004801	0.004267	0.003912
TABLE 1 (CUTOFF CONSTANTS)										
	FOR TM _m n WAVES				TM CUTOFF WAVELENGTH IN METER					
		0	1	2	3	0	1	2	3	
	1	2.613	1.64	1.224	0.996	1	0.02323	0.01458	0.010881	0.008854
	2	1.139	0.896	0.747	0.644	2	0.010126	0.007965	0.006641	0.005725
	3	0.726	0.618	0.541	0.482	3	0.006454	0.005494	0.004809	0.004285
	4	0.534	0.475	0.425	0.388	4	0.004747	0.004223	0.003778	0.003449
TABLE 2 (CUTOFF CONSTANTS)										

CIRCULAR WAVEGUIDE MODES

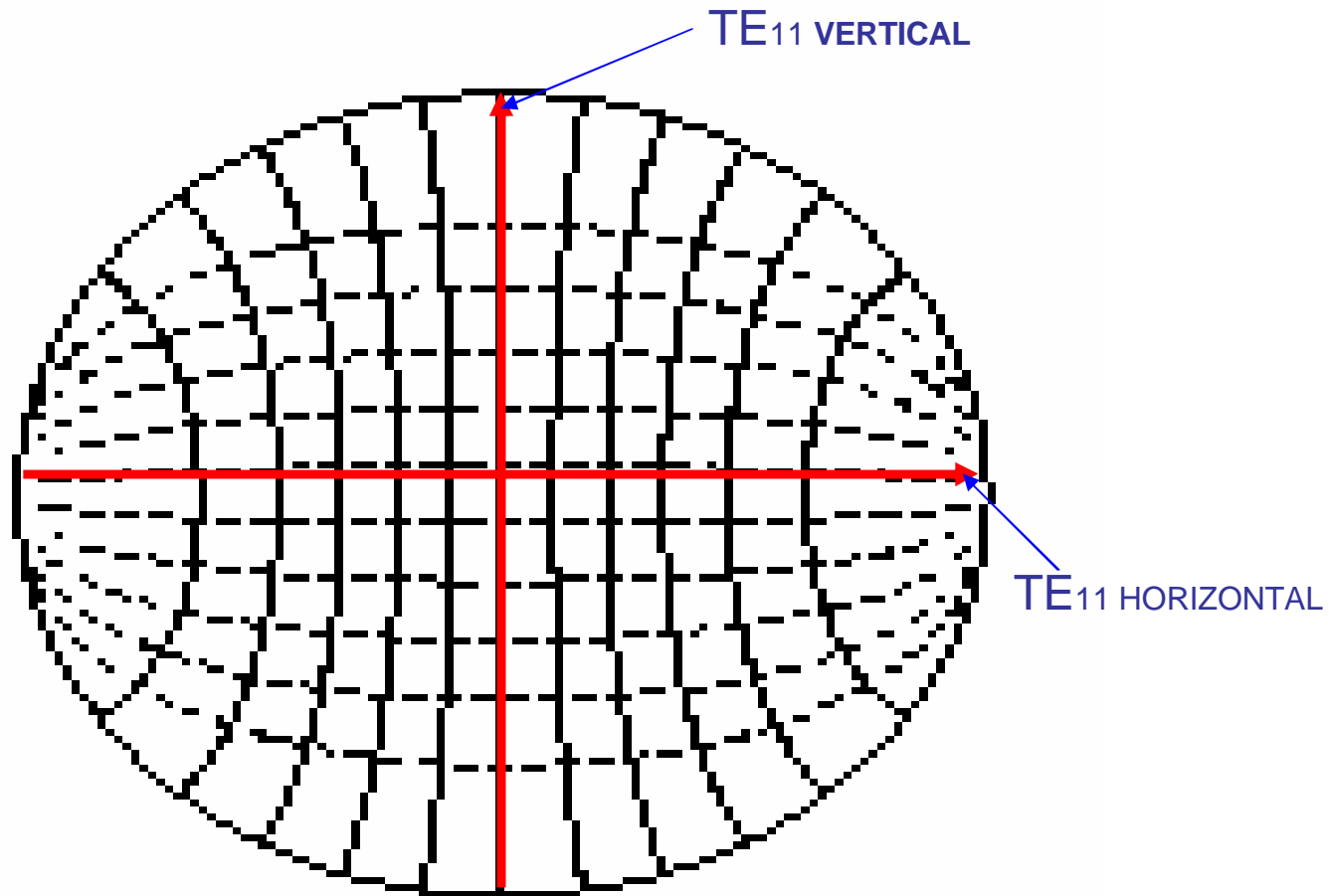

(1) TE_{11}

CIRCULAR WAVEGUIDE MODES

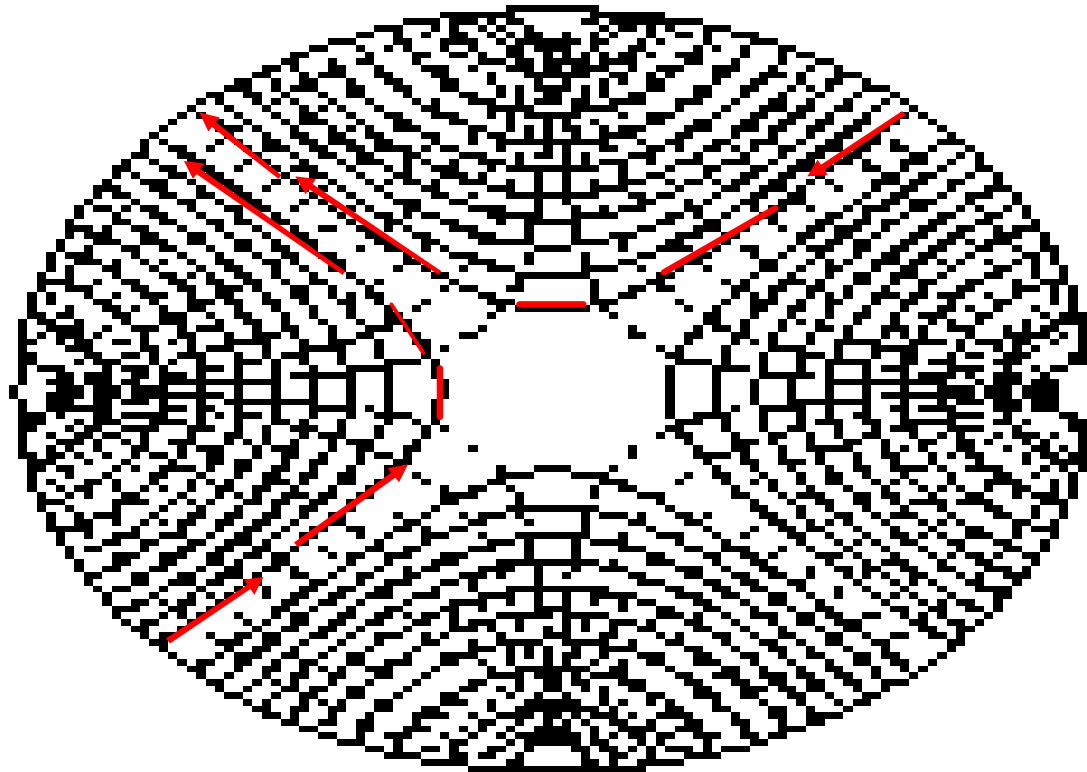

(3) TE_{21}

CIRCULAR WAVEGUIDE MODES

NOTE: THIS MODE HAS
AN AXIAL ELECTRIC FIELD

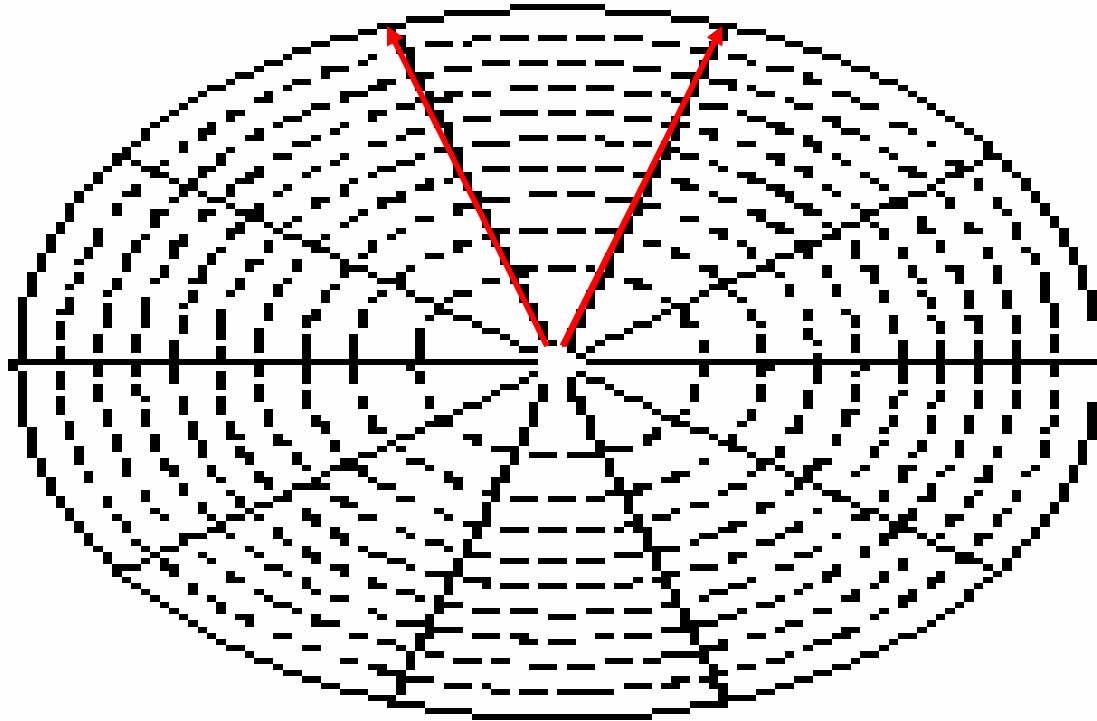

(2) TM_{01}

Titan Corporation

Datron Advanced Technologies Division

**200 West Los Angeles Ave.
Simi Valley, CA 93065
Phone: (805) 584-1717
Fax: (805) 526-3690**

HOW TO SETUP A MULTIMODE MODEL

A CIRCULAR WAVEGUIDE IS USED TO ILLUSTRATE THE SETUP
ONLY HALF GEOMETRY IS SHOWN

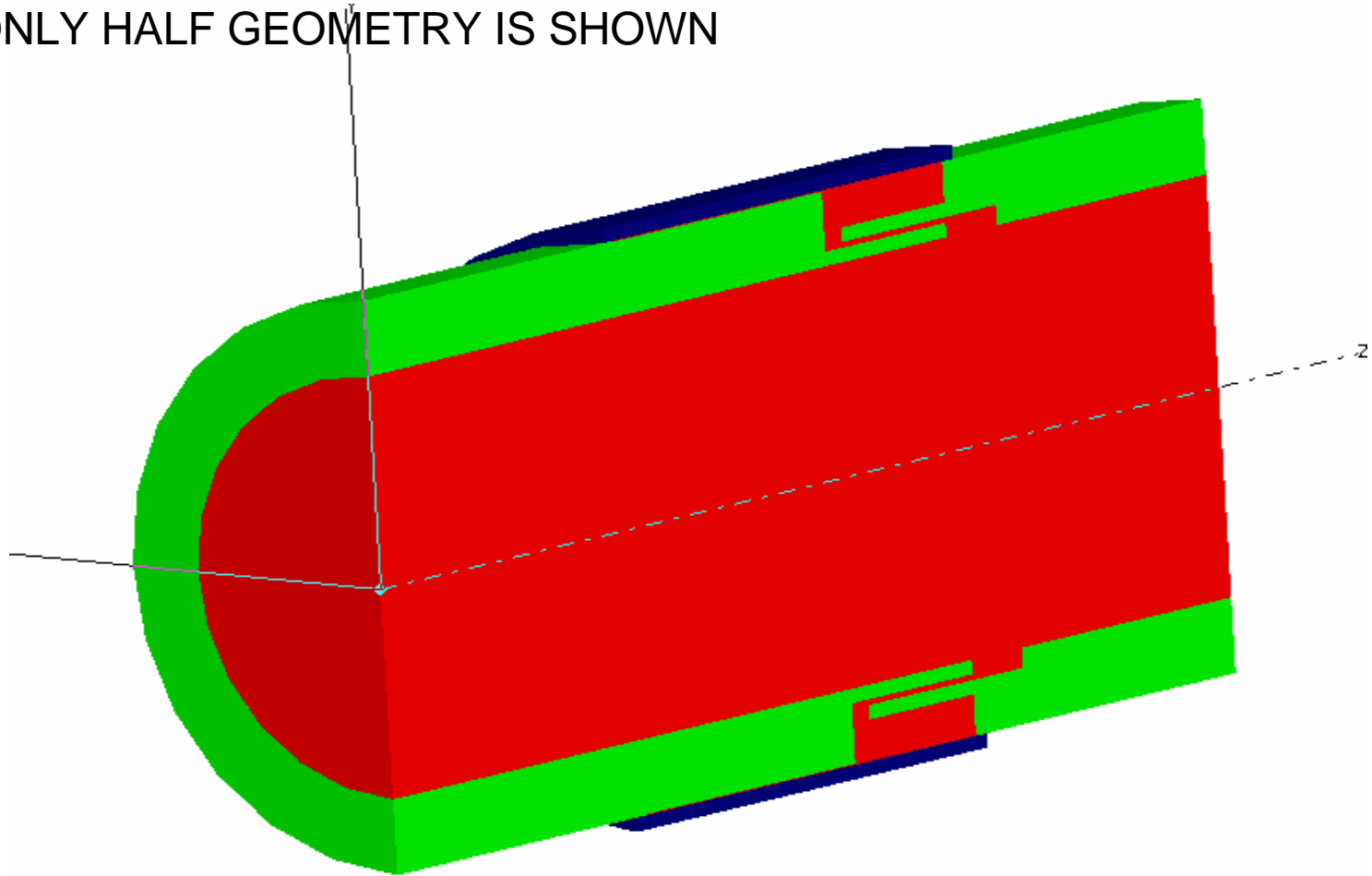

REQUIRES 4 MODES EVALUATION: TE_{11} VERTICAL , TE_{11} HORIZONTAL AND
2 ADDITIONAL MODES

Titan Corporation
Datron Advanced Technologies Division

STEP ONE) 3D MODEL

Rad | 1.49988332879594
Ang | 0
Snap To: Vertex
 Grid Other...
AIR
HOUSEBASE
HOUSCENTER
HOUSUPPER

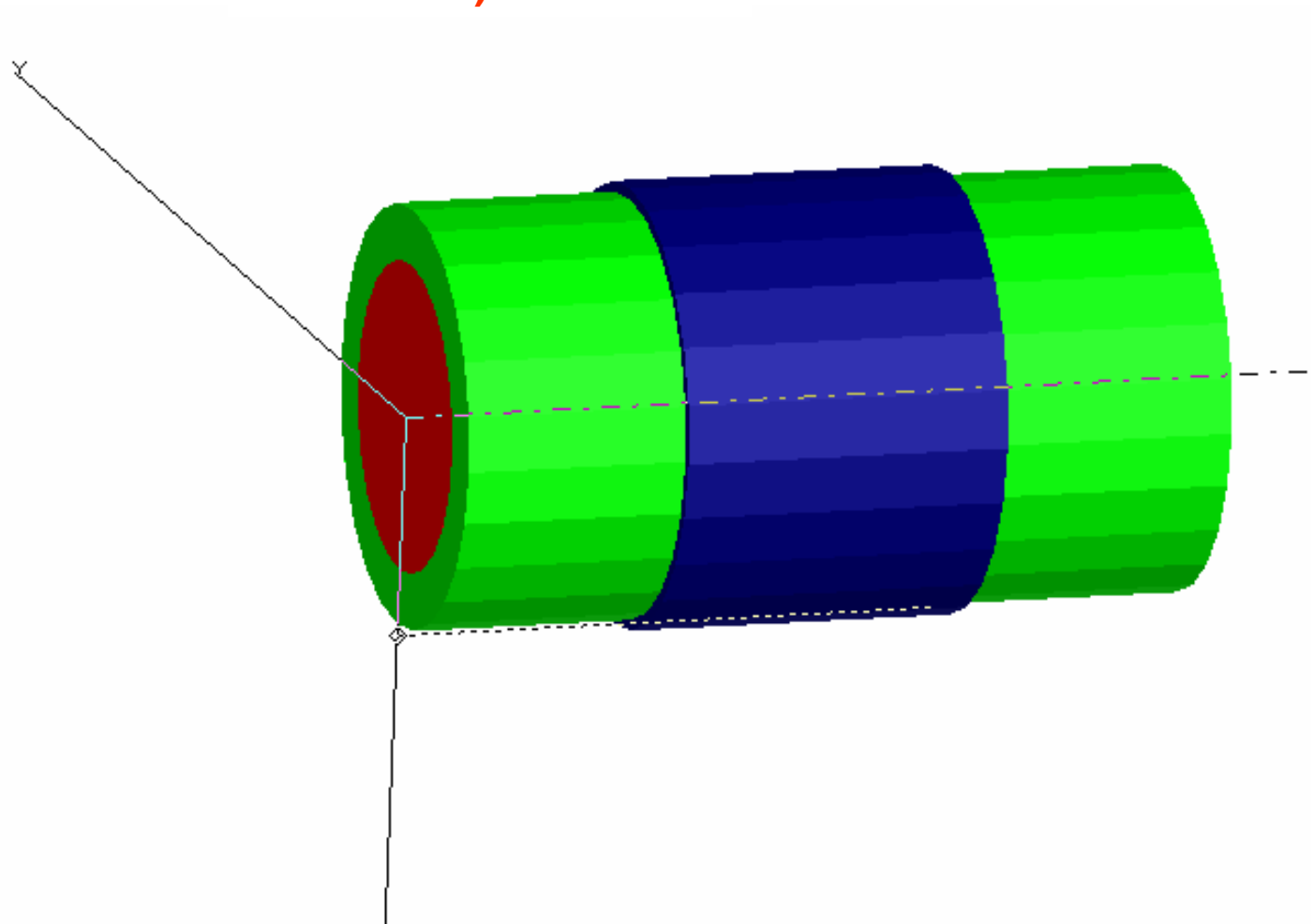

STEP 2) ASSIGNMENT OF MATERIALS

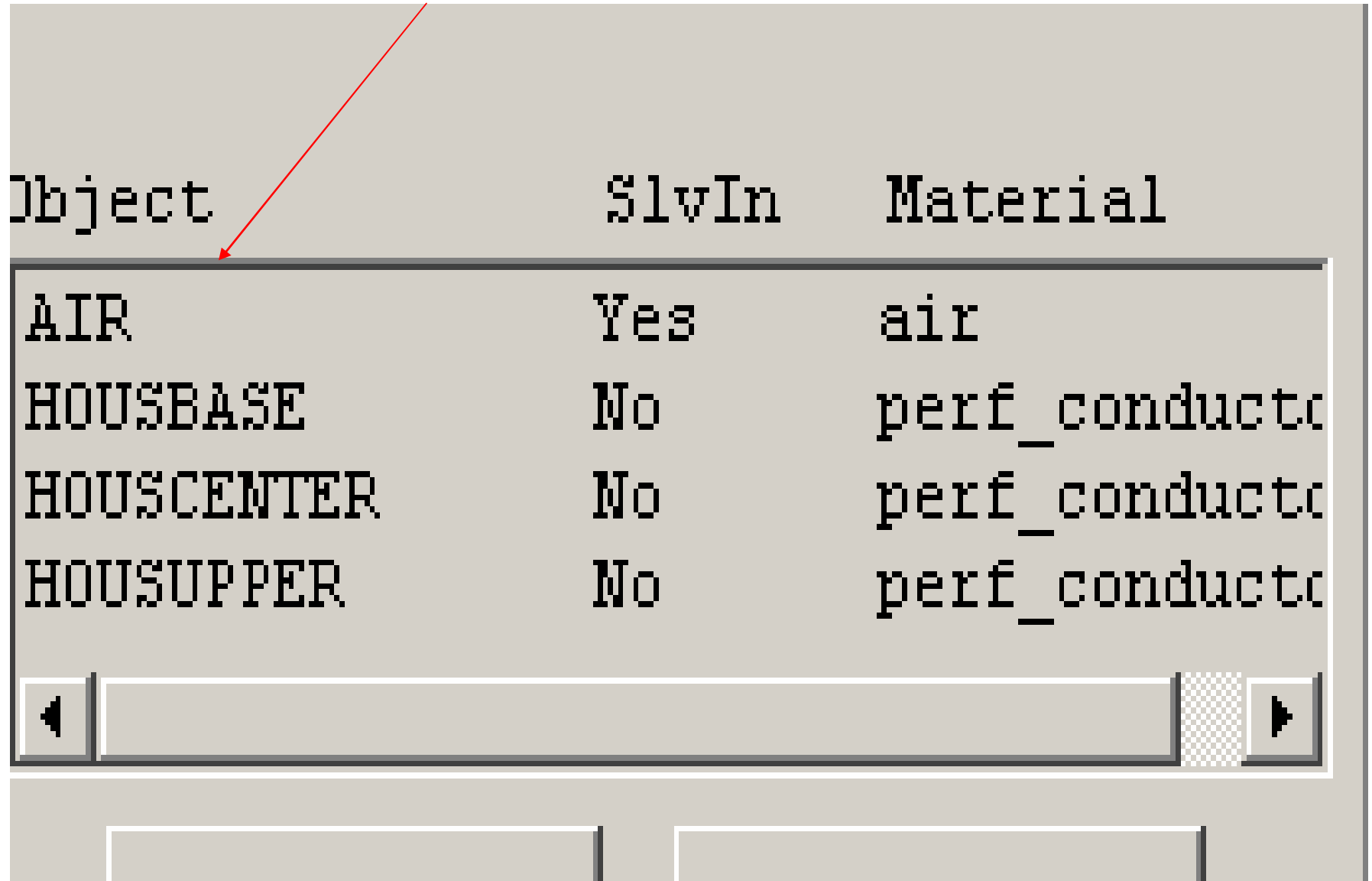

Object	SlvIn	Material
AIR	Yes	air
HOUSEBASE	No	perf_conducto
HOUSCENTER	No	perf_conducto
HOUSUPPER	No	perf_conducto

The screenshot shows a software window with a table. A red arrow points from the title 'STEP 2) ASSIGNMENT OF MATERIALS' to the 'Object' column header. The table has three columns: 'Object', 'SlvIn', and 'Material'. The rows are: AIR (Yes, air), HOUSEBASE (No, perf_conducto), HOUSCENTER (No, perf_conducto), and HOUSUPPER (No, perf_conducto). At the bottom of the window, there are two empty rectangular boxes and a scroll bar with left and right arrow buttons.

Step 3) TE11 MODE VERTICAL

X
 Y
 Z
 Rad
 Ang
 Snap To: Vertex
 Grid Other...

Graphical Pick

Object
 Face
 Boundary

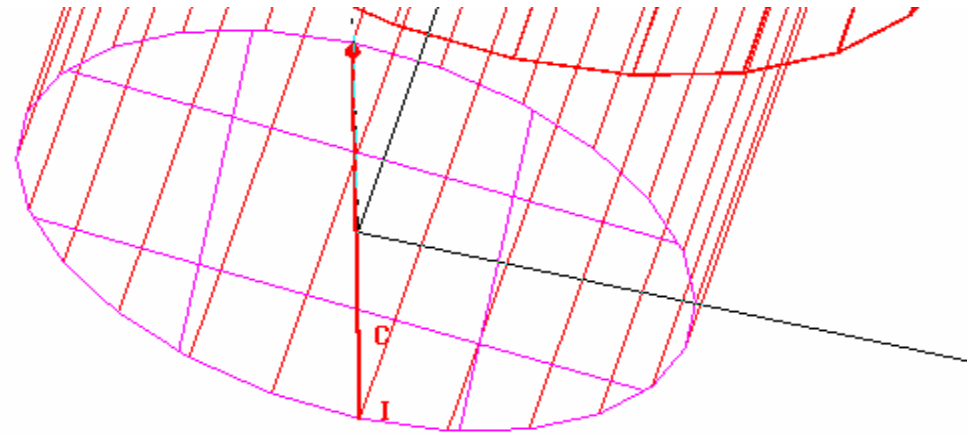

Name	Assigned
port1	port
port2	port

Name:

Source Boundary

Port

Boundary/Source:

Assign

Clear

Units...

Options...

View Modes

Num: Enter

Mode	Imped	Calib
1	Y	Y
2	Y	Y
3	Y	Y
4	Y	Y

Polarize E Field

Type: Define Terminal

Use Impedance Line

[(-0.368,-2.56739074445E-015,0), (0.368,0,

Use Calibration Line

[(-0.368,-2.56739074445E-015,0), (0.368,0,

Imped Multiplier (entire model):

Titan Corporation
Datron Advanced Technologies Division
Step 4) TE₁₁ MODE HORIZONTAL

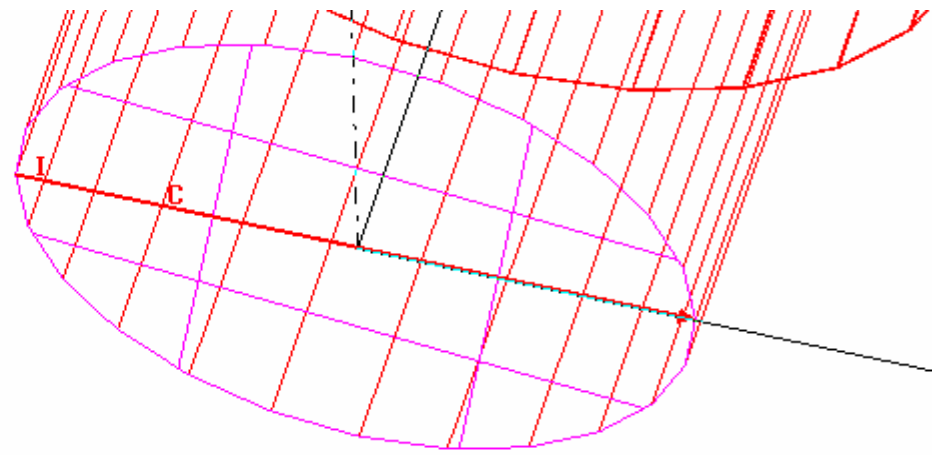

0.525
 0
 1.405
 1.49988332879594
 90
 To: Vertex
 Other...

Graphical Pick

Object
 Face
 Boundary

Assigned

port
port

Name: Source Boundary Port

Boundary/Source:

View Modes

Num:

Mode	Imped	Calib
1	Y	Y
2	Y	Y
3	Y	Y
4	Y	Y

Polarize E Field

Type: Define Terminations

Use Impedance Line

Use Calibration Line

Imped Multiplier (entire model):

STEP 5) HOW THE MODE 3,4 NEEDS TO BE SETUP

X 0.525
 Y 0
 Z 1.405
 Rad 1.49988332879594
 Ang 90
 Snap To: Vertex
 Grid Other...

Graphical Pick

Object
 Face
 Boundary

Name	Assigned
port1	port
port2	port

Name: Source Boundary Port

Boundary/Source:

View Modes

Num:

Mode	Imped	Calib
1	Y	Y
2	Y	Y
3	Y	Y
4	Y	Y

Polarize E Field

Type: Define Terminal

Use Impedance Line

Use Calibration Line

Imped Multiplier (entire model):

RESULTS

AFTER SOLUTION IS OBTAINED, USE SETUP EXECUTIVE PARAMETERS AND CHOOSE "PORT IMPEDANCES"

TE₁₁ VERT.

X 0.525
 Y 0
 Z 1.405
Rad 1.49988332879594
Ang 90
Snap To: Vertex
 Grid Other...

Graphical Pick

Object
 Face
 Boundary

Name	Assigned
port1	port
port2	port

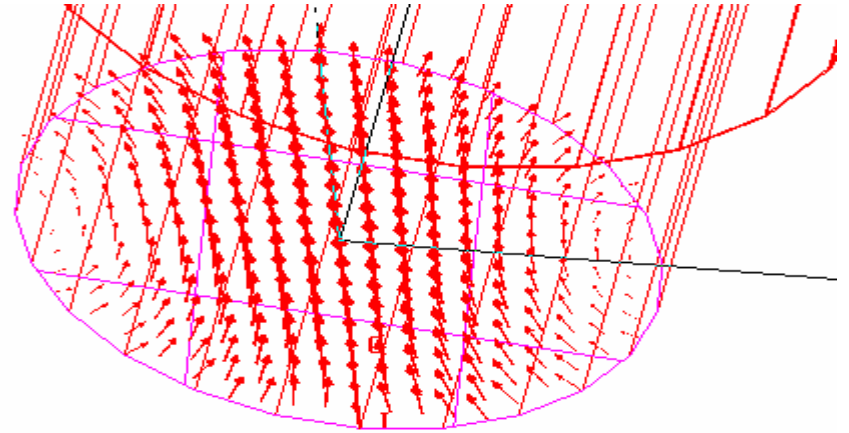

Name: port1 Source Boundary Port Port

Boundary/Source: View Modes Type: Wave Port Defir

Assign Enter

Num: 4

Mode	Imped	Calib
1	Y	Y
2	Y	Y
3	Y	Y
4	Y	Y

Use Impedance Line
[(-0.368,-2.56739074445E-015,0),

Use Calibration Line
[(-0.368,-2.56739074445E-015,0),

Polarize E Field Imped Multiplier (entire model):

RESULTS

TE₁₁ HORIZ.

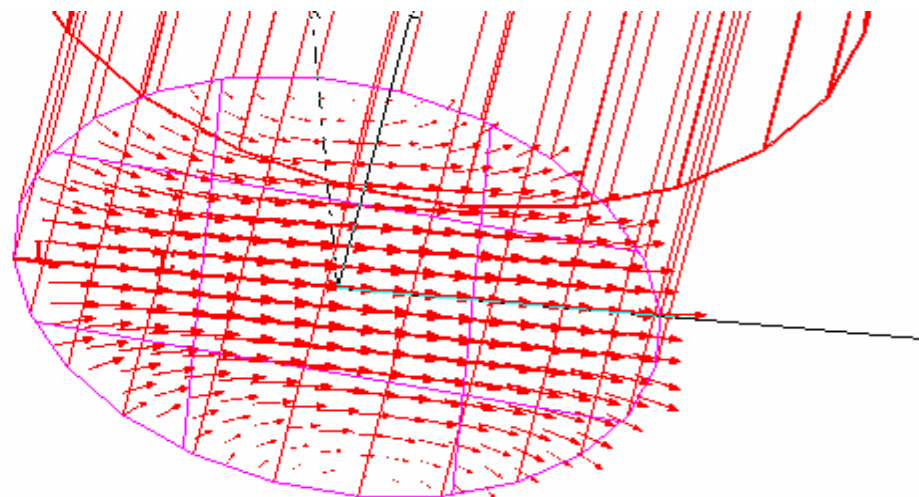

Abs. [inches] ▾

X 0.525

Y 0

Z 1.405

Rad 1.49988332879594

Ang 90

Snap To: Vertex

Grid Other...

Graphical Pick

Object

Face

Boundary

Name	Assigned
port1	port
port2	port

Name: port1

Source Boundary

Port ▾ Port Fields

Boundary/Source:

Assign

Clear

View Modes ▾

Num: 4 Enter

Mode	Imped	Calib
1	Y	Y
2	Y	Y
3	Y	Y
4	Y	Y

Type: Wave Port ▾ Define Term

Use Impedance Line Edit

Units...

Options...

Use Calibration Line Edit

688E-015, -0.368, 0), (-1.29063426613E-015

688E-015, -0.368, 0), (-1.29063426613E-015

RESULTS

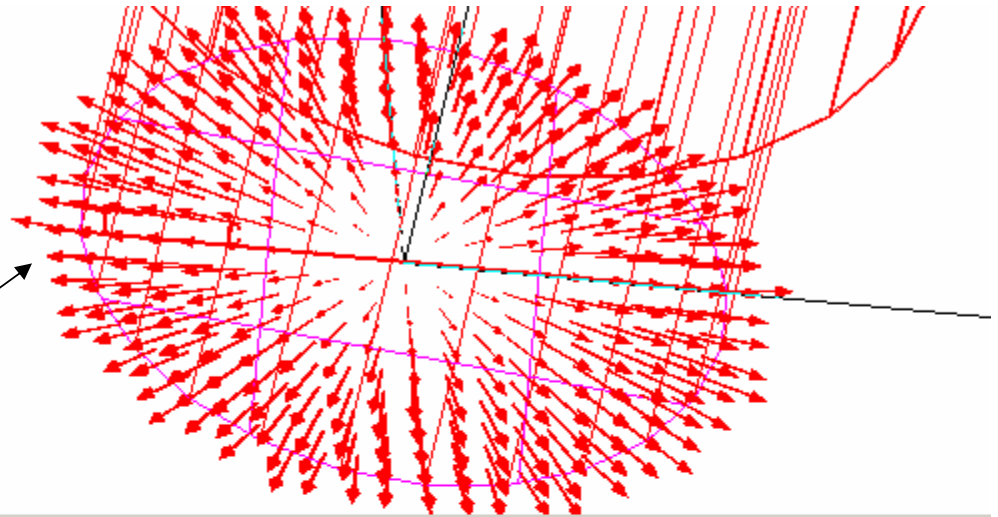

X 0.525
 Y 0
 Z 1.405
 Rad 1.49988332879594
 Ang 90
 Snap To: Vertex
 Grid Other...

Graphical Pick

Object
 Face
 Boundary

Name	Assigned
port1	port
port2	port

Name: port1

Source Boundary

Port ▼ Port Field

Boundary/Source:

Assign

Clear

Units...

Options...

View Modes ▼

Num: 4 Enter

Mode	Imped	Calib
1	Y	Y
2	Y	Y
3	Y	Y
4	Y	Y

Type: Wave Port ▼ Define Term

Use Impedance Line Ed:
 [688E-015,-0.368,0), (-1.29063426613E-01.

Use Calibration Line Ed:
 [688E-015,-0.368,0), (-1.29063426613E-01.

RESULTS

Abs. [inches] ▾

X 0.525

Y 0

Z 1.405

Rad 1.49988332879594

Ang 90

Snap To: Vertex

Grid Other...

Graphical Pick

Object

Face

Boundary

Name	Assigned
port1	port
port2	port

TE₂₁

Name: port1

Source Boundary

Port ▾ Port File

Boundary/Source:

Assign

Clear

Units...

Options...

View Modes ▾

Num: 4 Enter

Mode	Imped	Calib
1	Y	Y
2	Y	Y
3	Y	Y
4	Y	Y

Type: Wave Port ▾ Define Te

Use Impedance Line

688E-015,-0.368,0), (-1.29063426613E-

Use Calibration Line

688E-015,-0.368,0), (-1.29063426613E-

HEMISPHERICAL LENS ON A GROUND PLANE (EXAMPLE NO 5)

- **LUNEBERG** LENSES ARE USUALLY USED FOR WIDE ANGLE SCANNING APPLICATIONS LIKE FOR RADAR REFLECTORS.
- THE INDEX OF REFRACTION VARIES ALONG THE RADIUS OF THE LENS.

HEMISPHERICAL LUNEBURG LENS ON A GROUND PLANE WITH TWO ORTHOGONAL FEED ANTENNA

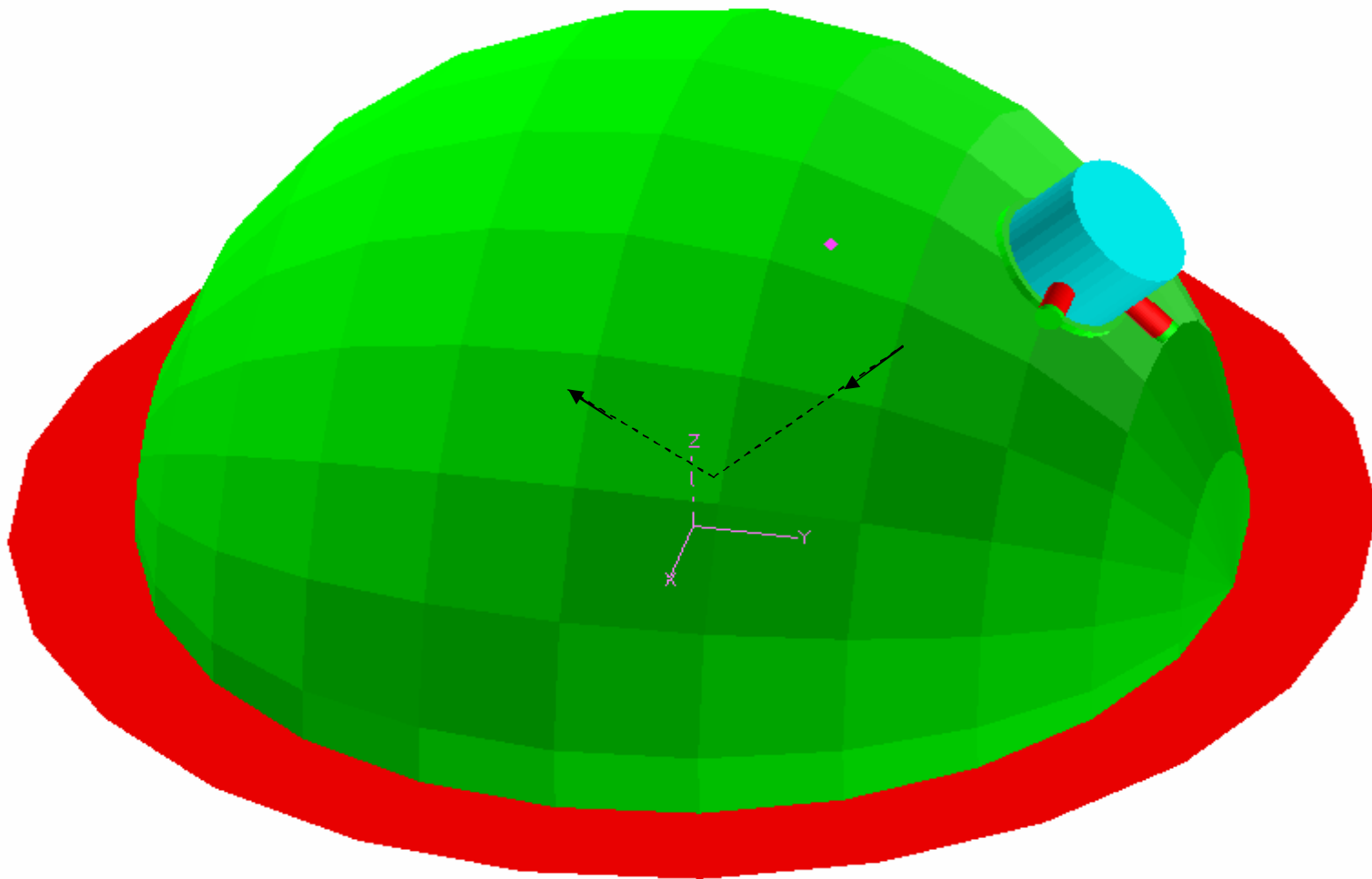

LENS (ONLY HALF SHOWN), HORN ANTENNA AND GROUND PLANE

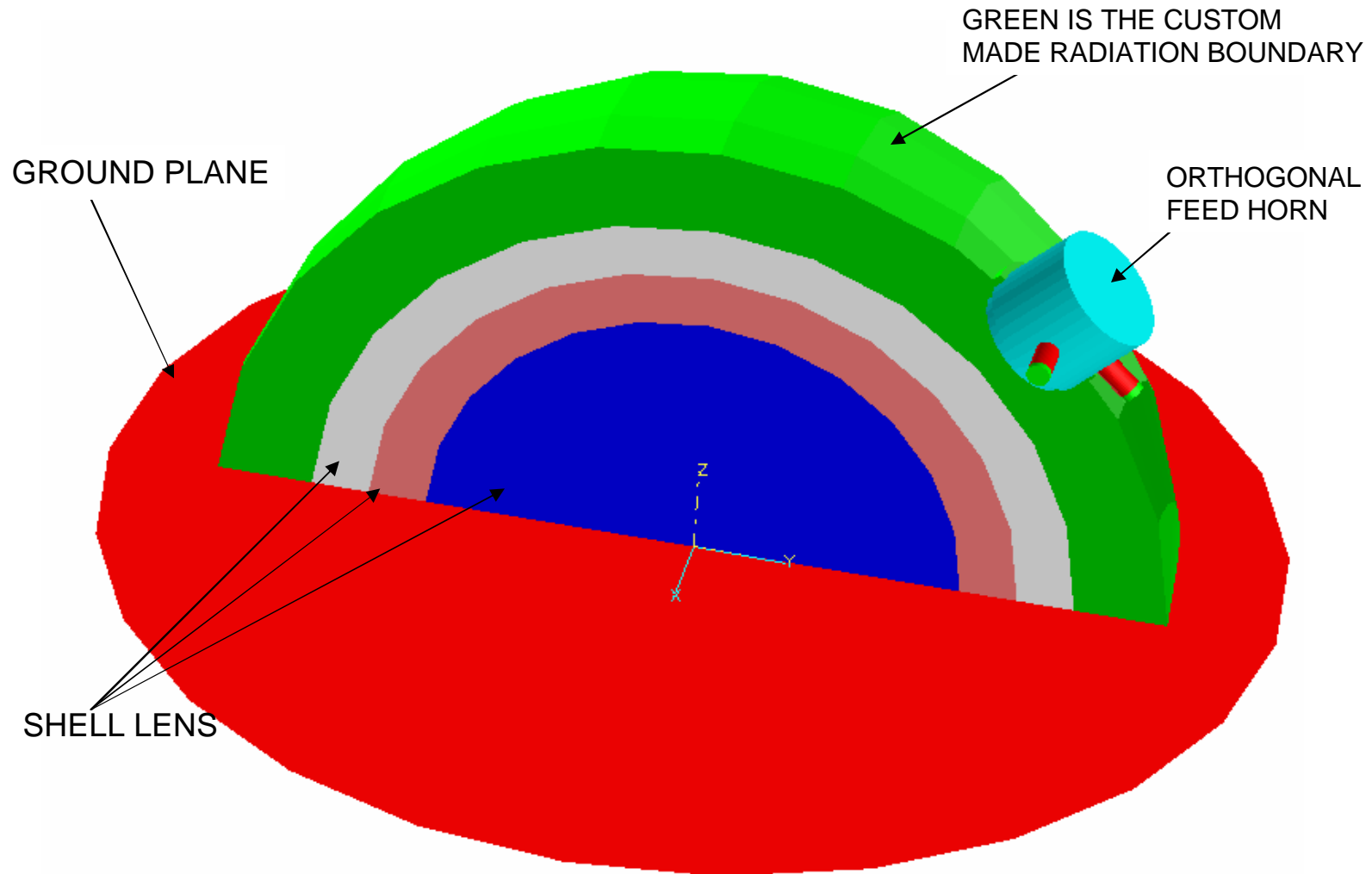

FOR A TYPICAL LUNEBERG LENS THE RELATIVE DIELECTRIC CONSTANT (ϵ_r) WILL VARY FROM $\epsilon_r = 2$ AT THE CENTER TO $\epsilon_r = 1$ AT THE OUTER SURFACE OF THE LENS

THEORETICAL (HFSS) VERSUS MEASURED DATA OF A HEMISPHERICAL LUNEBERG LENS, HORN AND GROUND PLANE

RED: MEASURED DATA

BLUE: HFSS PREDICTED

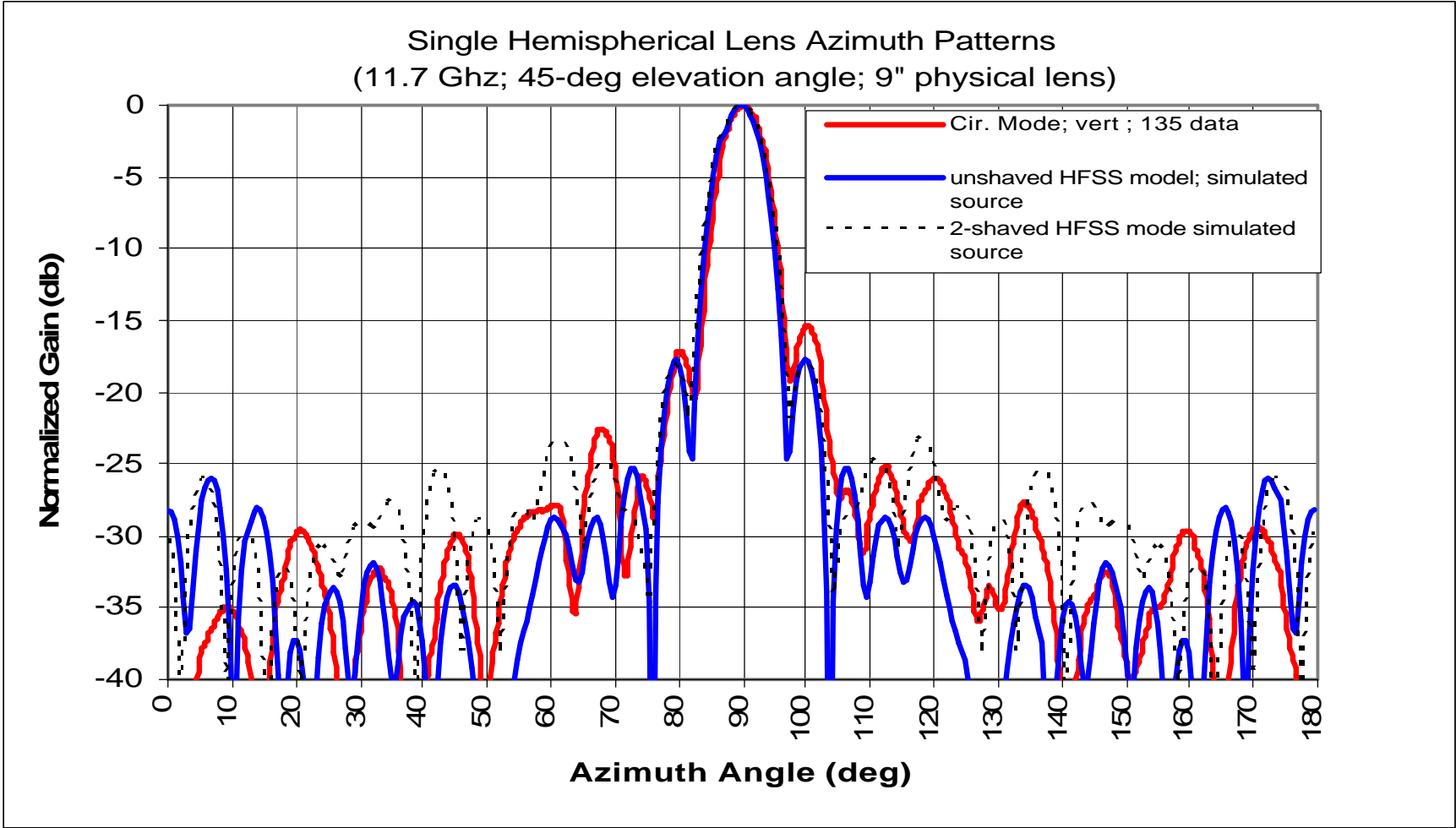

CROSSED DIPOLES FEED WITH REFLECTOR (EXAMPLE NO 6)

THIS IS A TYPICAL DIPOLE
REFLECTOR DESIGN

THE REFLECTOR DIPOLE MESHING BY HFSS

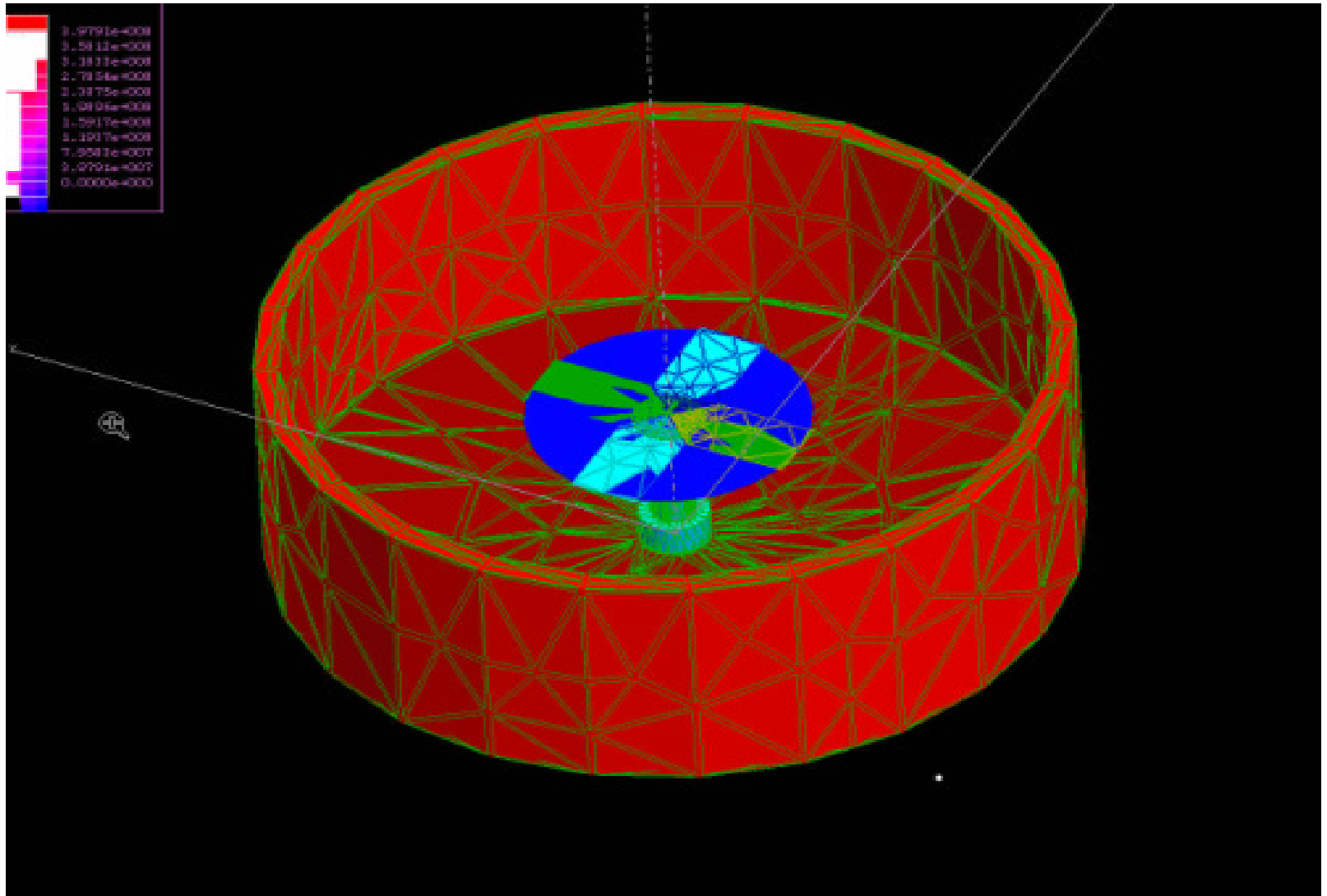

REFLECTOR FEED WITHOUT DIELECTRIC PLATE

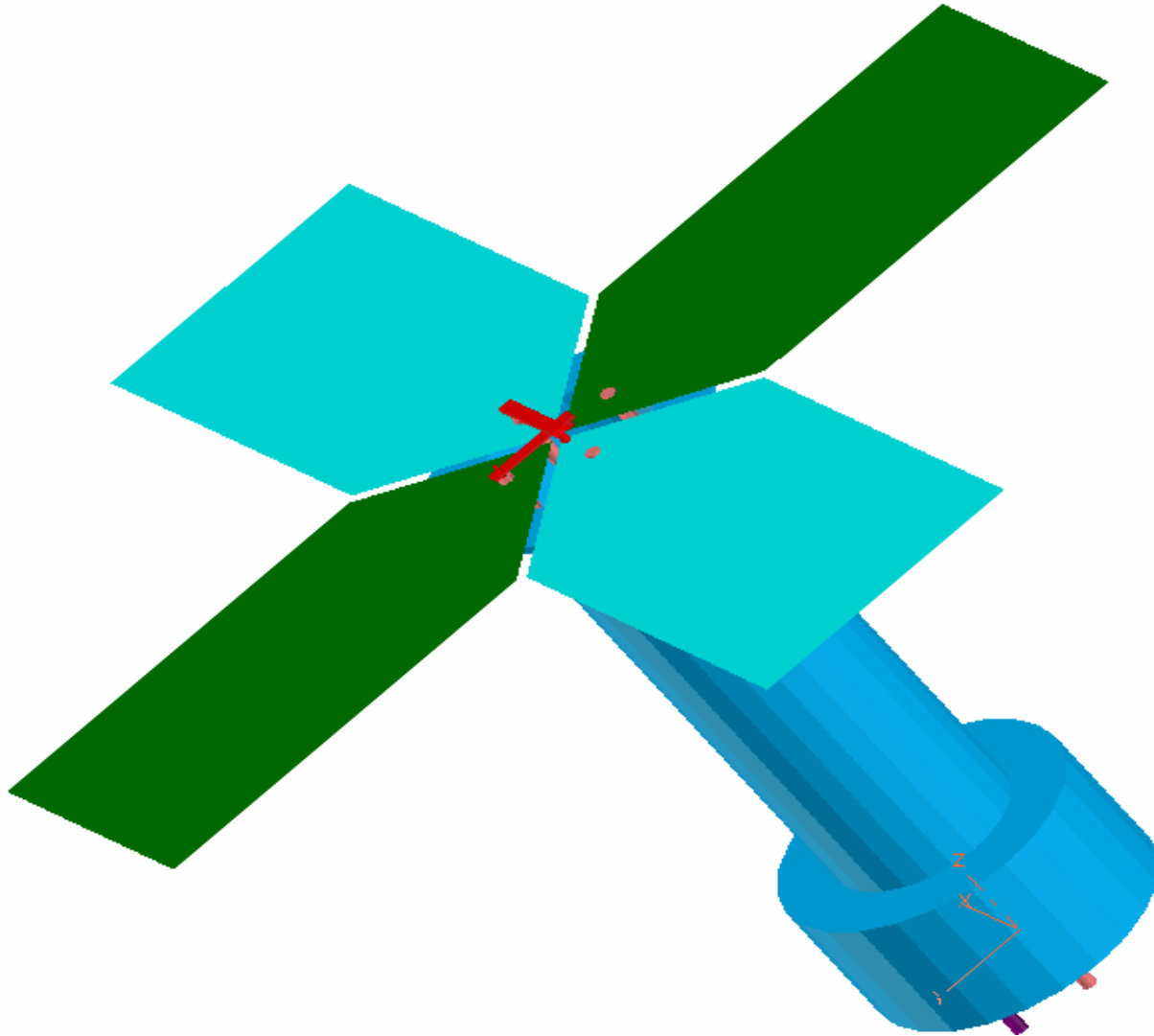

REFLECTOR FEED COAXIAL LINES SEEN FROM THE BOTTOM

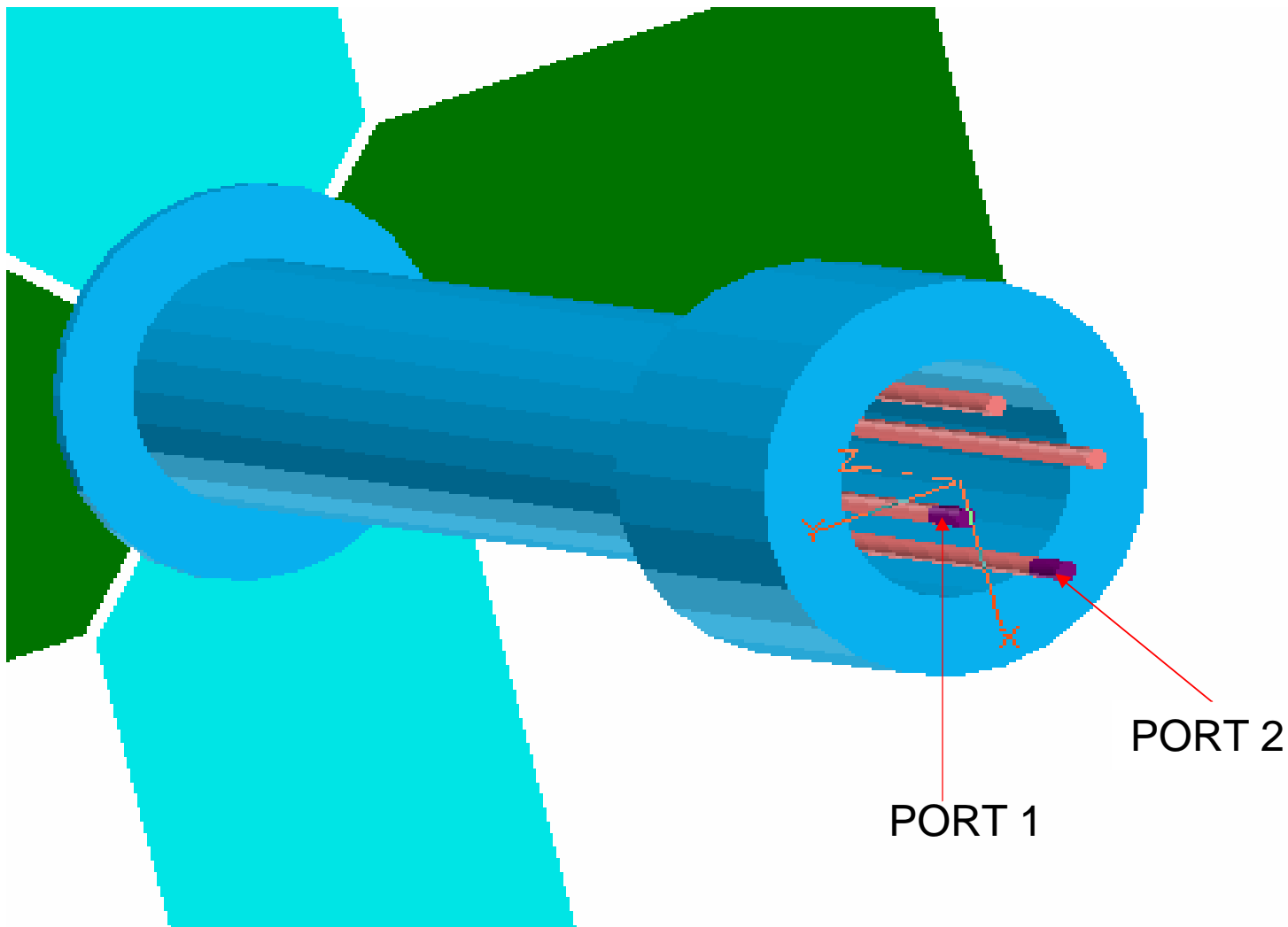

DIPOLES FEED COMPONENT WITH A DIELECTRIC DISK

THIS SIDE WAS MADE PERFECT E
TO SIMULATE DIELECTRIC GROUND
PLANE

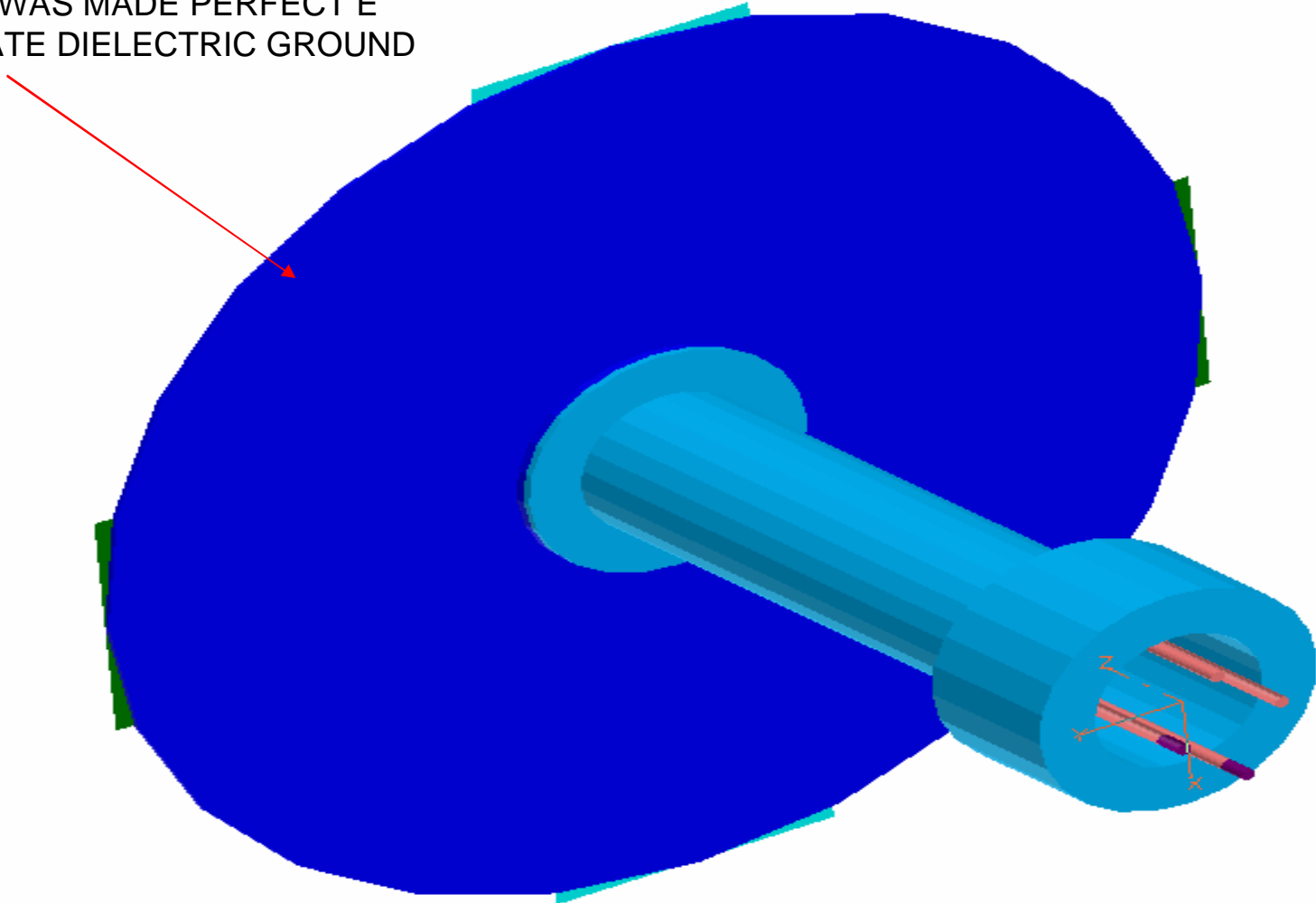

THEORETICAL MODEL VERSUS EXISTING DESIGN MEASURED DATA
HFSS MODELS, AZIMUTH PLANE AT 240 MHz

