

BreconRidge

Manufacturing Solutions

A Novel Technique for the Design of High-Speed 10 and 40 Gb/s Compact Modules

Hassan Kobeissi

Senior RF Design Engineer,
BreconRidge Manufacturing Solutions

February 19-20 2004

Your Strategic
EMS Partner



Material is property of BreconRidge

Copyright 2004

BreconRidge
Manufacturing Solutions

Outline

- Means of using ANSOFT HFSS to design RF Transmission Line (TL) carriers by the employing a new technique in the 10 Gb/s and 40 Gb/s domain.
- Summary of the ways to change the capacitance and the inductance in a microstrip TL.
- Case studies:
 - Transition between different configurations
 - 50 Ohm resistive termination
 - RF carrier containing a DC block capacitor
 - Ball Grid Arrays (BGA)
- Conclusions

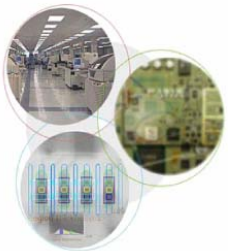

The Design Procedure and Advantages

ANSOFT HFSS Hfworkshop04

- The principle of the technique is to vary the *position of the reference ground* to achieve a step in the *cross-sectional dimension* of the structure.
- In essence, our *main* design variable becomes the *depth of the ground planes* with respect to the signal traces.
- In most cases, exploring the involved effects, allows for decreasing the length of *planar* tapers (step) at the discontinuities and, as such, save real-estate.
- The method leads to *good* dispersion properties and overall electrical performance in broad frequency bands.
- It has been successfully employed to design *volume manufacturability* high speed modules.

Your Strategic
EMS Partner



Material is property of BreconRidge

Copyright 2004

BreconRidge
Manufacturing Solutions

Summary of the Ways to Change the Capacitance and the Inductance in a Microstrip TL

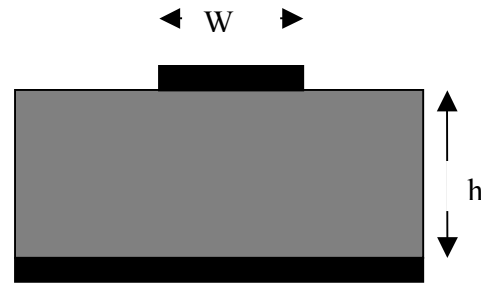

$C \nearrow \nearrow$	$W \nearrow$	$h \searrow$	$L \nearrow \nearrow$	$W \searrow$	$h \nearrow$
$C \nearrow$	$W \nearrow$	$h =$	$L \nearrow$	$W \searrow$	$h =$
$C \nearrow$	$W =$	$h \searrow$	$L \nearrow$	$W =$	$h \nearrow$
$Z =$	$W \nearrow$	$h \nearrow$	$Z =$	$W \searrow$	$h \searrow$

ANSOFT HFSS Hfworkshop04

Your Strategic
EMS Partner



Material is property of BreconRidge

Copyright 2004

BreconRidge
Manufacturing Solutions

Transition Between Different Configurations Description

ANSOFT HFSS Hfworkshop04

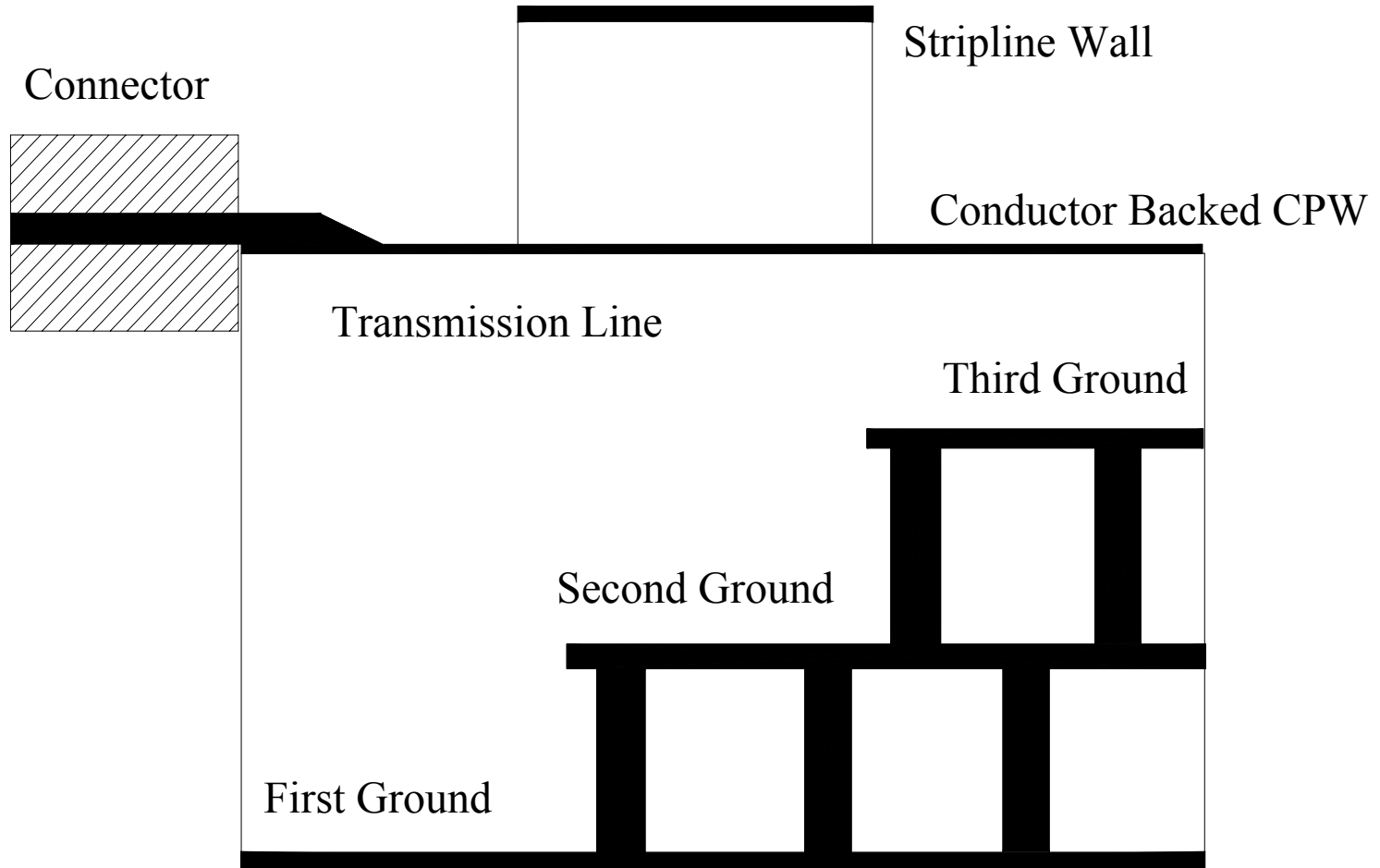

Your Strategy...
EMS Partner



Material is property of BreconRidge
Copyright 2004

BreconRidge
Manufacturing Solutions

Transition Between Different Configurations Results

ANSOFT HFSS Hfworkshop04

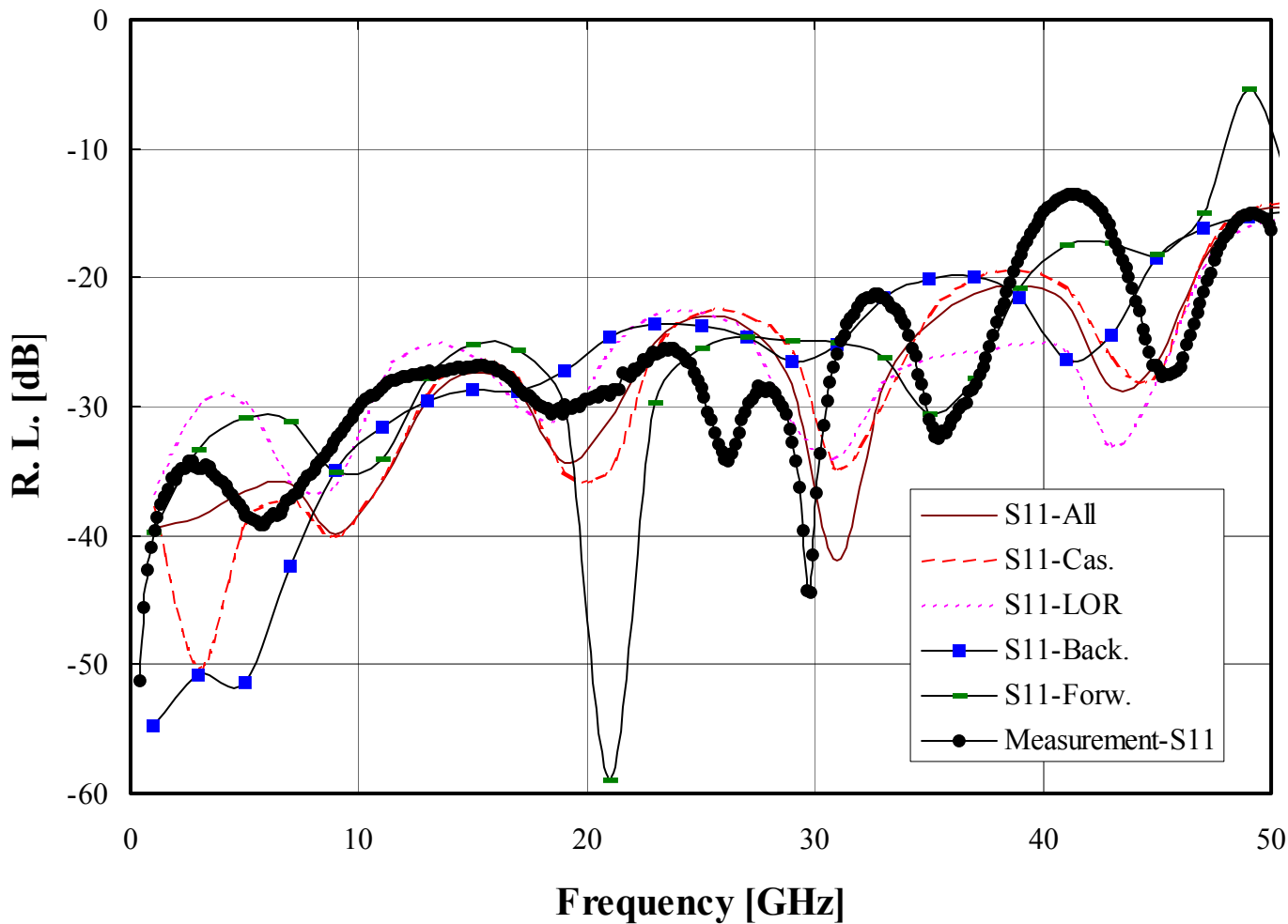

Your Strategic
EMS Partner



Material is property of BreconRidge

Copyright 2004

BreconRidge
Manufacturing Solutions

Transition Between Different Configurations Results Cont'd

ANSOFT HFSS Hfworkshop04

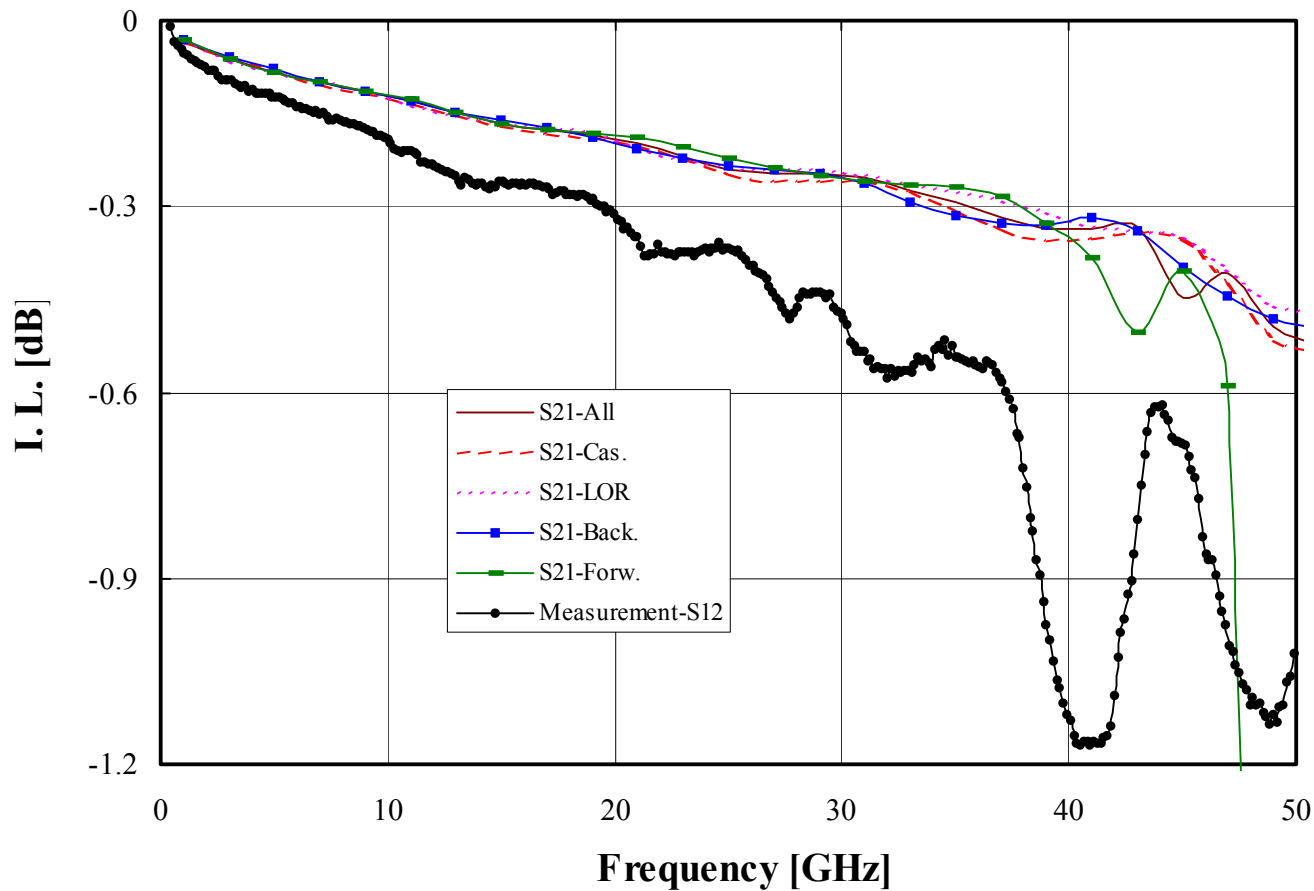

Your Strategic
EMS Partner



Material is property of BreconRidge

Copyright 2004

BreconRidge
Manufacturing Solutions

50 Ohm Resistive Termination Description

ANSOFT HFSS Hfworkshop04

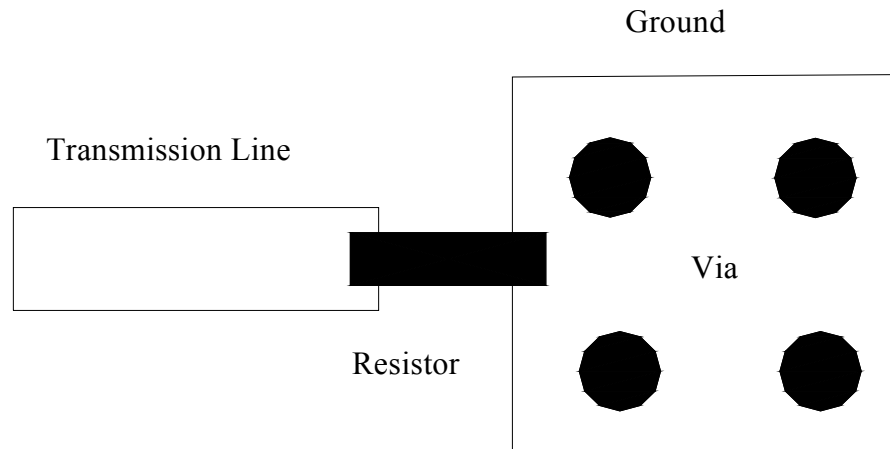
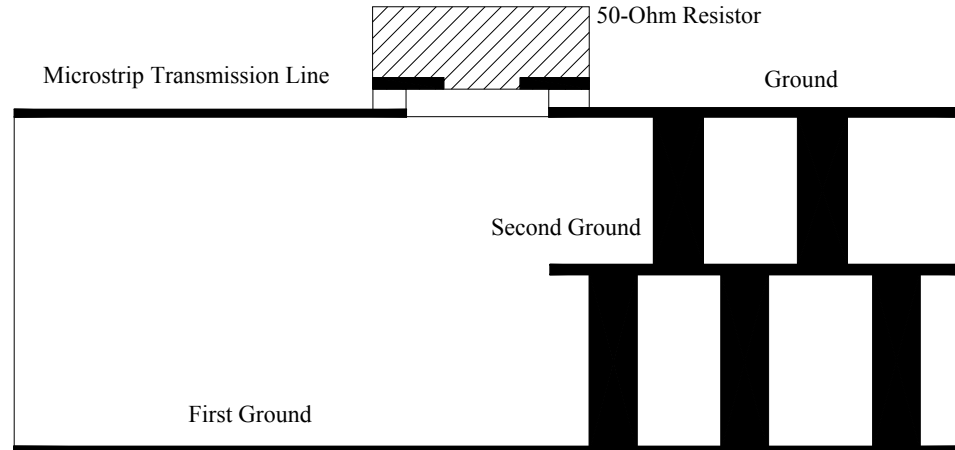

Your Strategic
EMS Partner



Material is property of BreconRidge
Copyright 2004

BreconRidge
Manufacturing Solutions

50 Ohm Resistive Termination Cont'd

Equivalent circuit of the resistive load

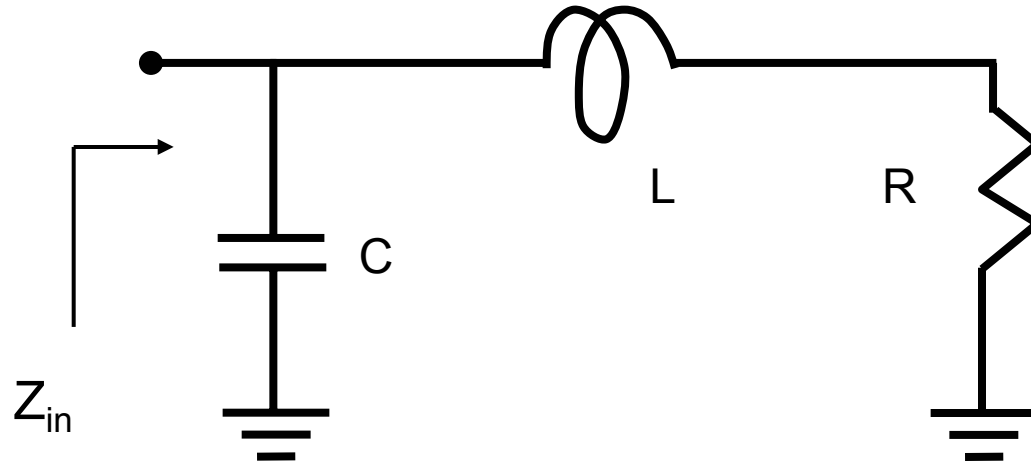

Input impedance of a typical load of resistive impedance

$$Z_{in} = \frac{R + j\omega L}{1 + j\omega CR - \omega^2 CL}$$

$$L \ll$$

$$\omega^2 CL \ll 1$$

$$j\omega CR = j\omega L/R$$

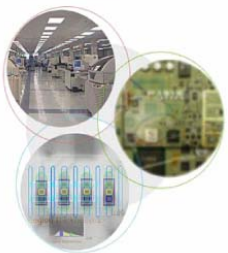

50 Ohm Resistive Termination Results

ANSOFT HFSS Hfworkshop04

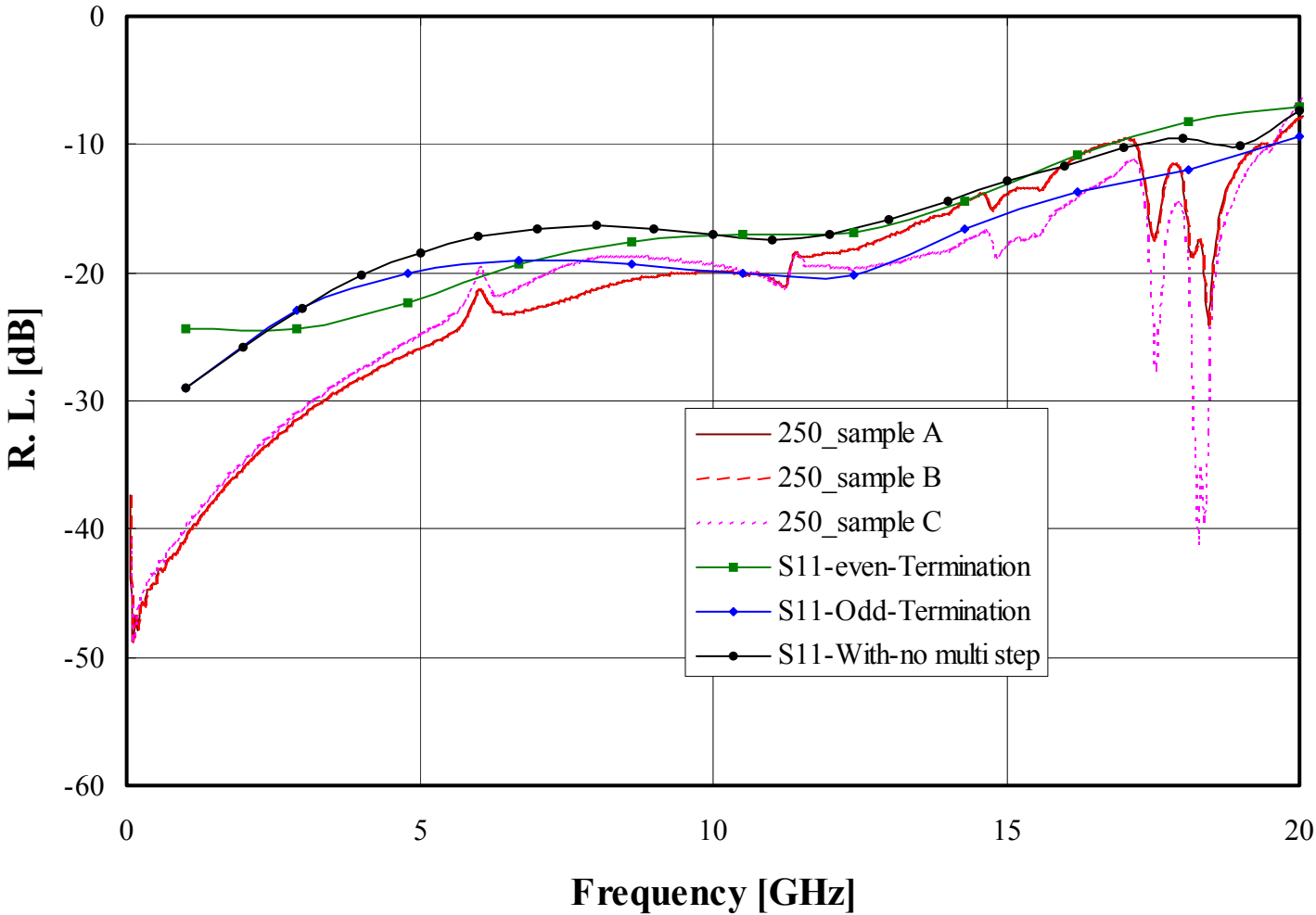

Your Strategic EMS Partner



Material is property of BreconRidge

Copyright 2004

BreconRidge Manufacturing Solutions

RF Carrier Containing a DC Block Capacitor

ANSOFT HFSS Hfworkshop04

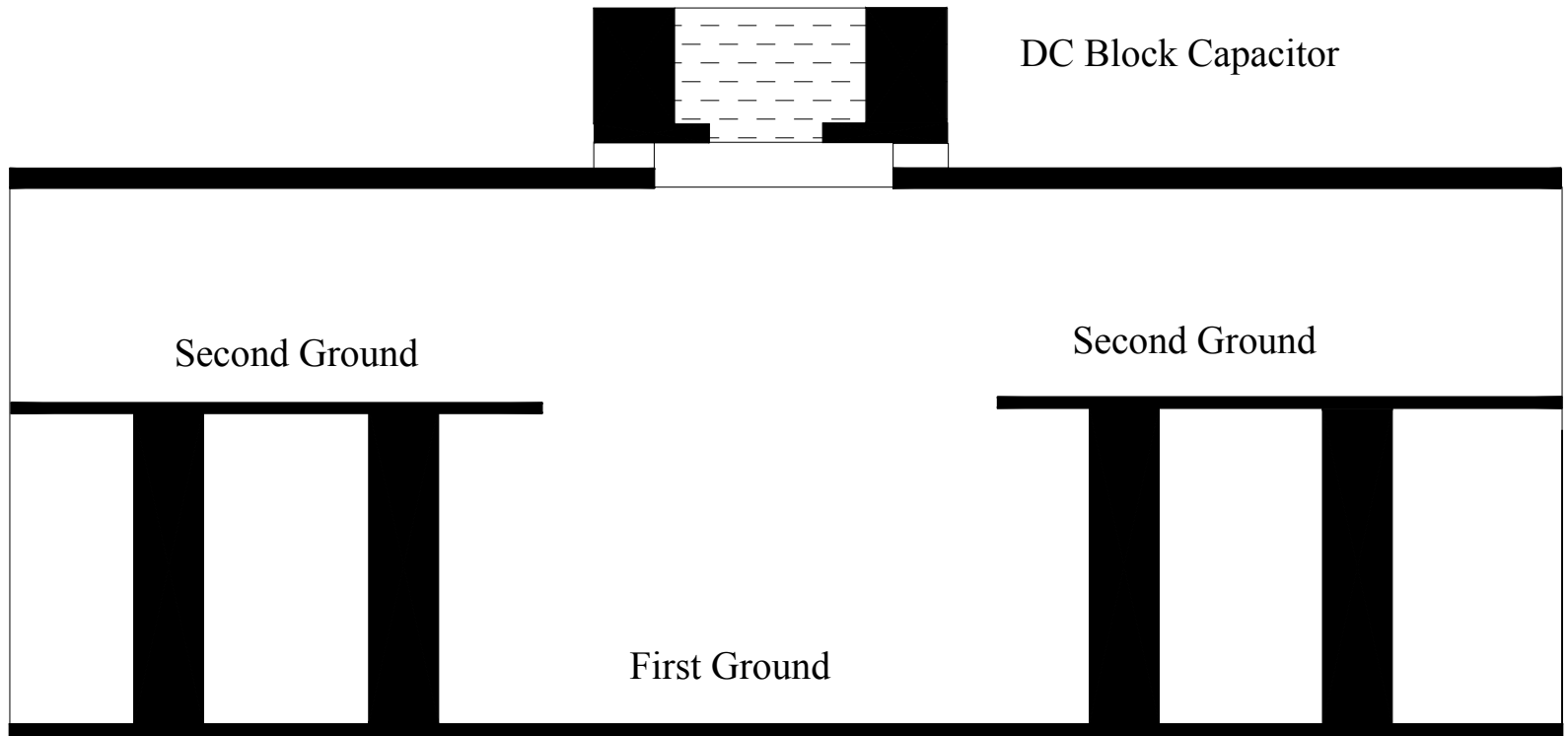

Your Strategic
EMS Partner



Material is property of BreconRidge
Copyright 2004

BreconRidge
Manufacturing Solutions

RF Carrier Containing a DC block Capacitor Cont'd

ANSOFT HFSS Hfworkshop04

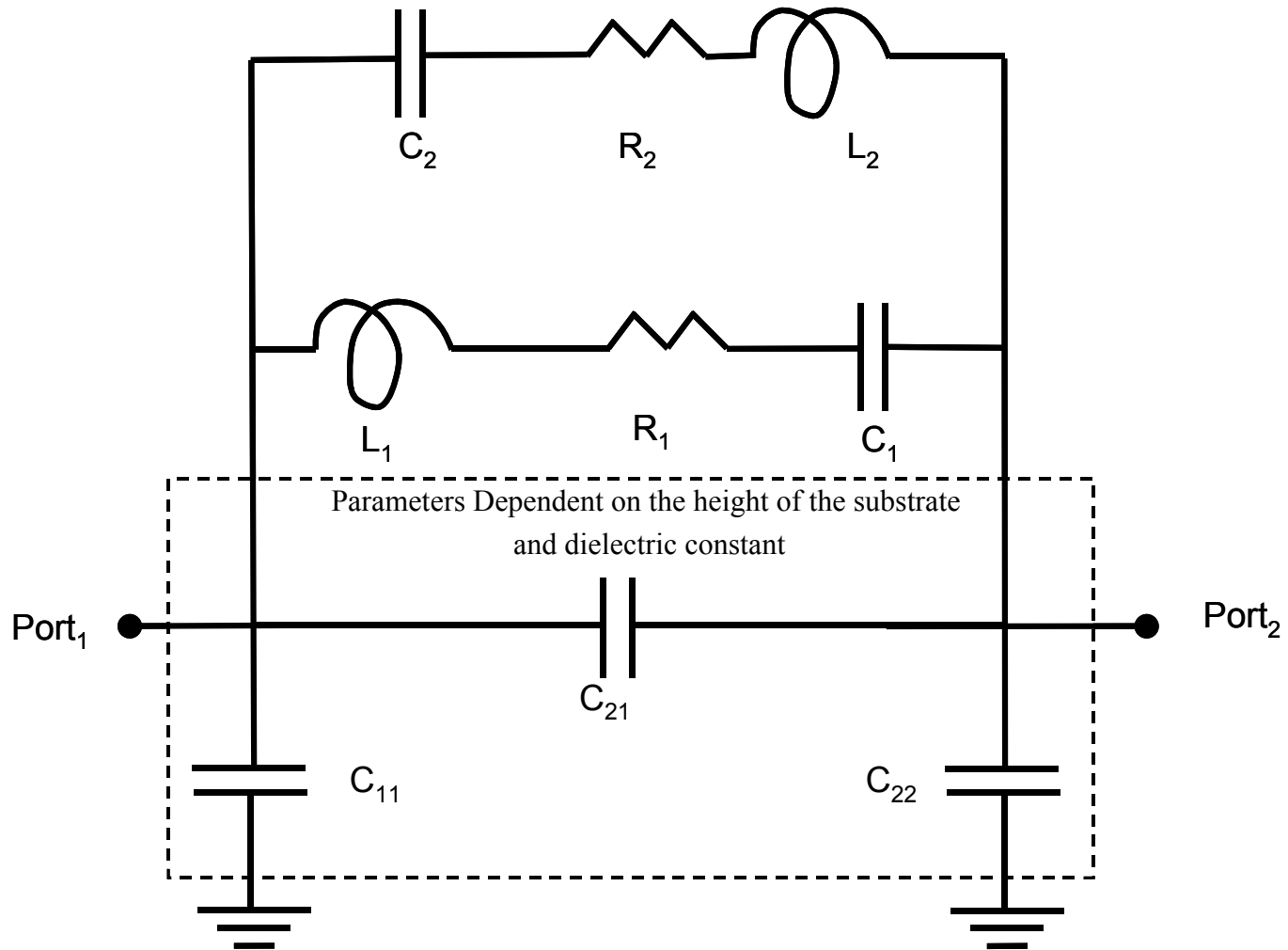

Your Strategic
EMS Partner



Material is property of BreconRidge

Copyright 2004

BreconRidge
Manufacturing Solutions

RF Carrier Containing a DC Block Capacitor Results

ANSOFT HFSS Hfworkshop04

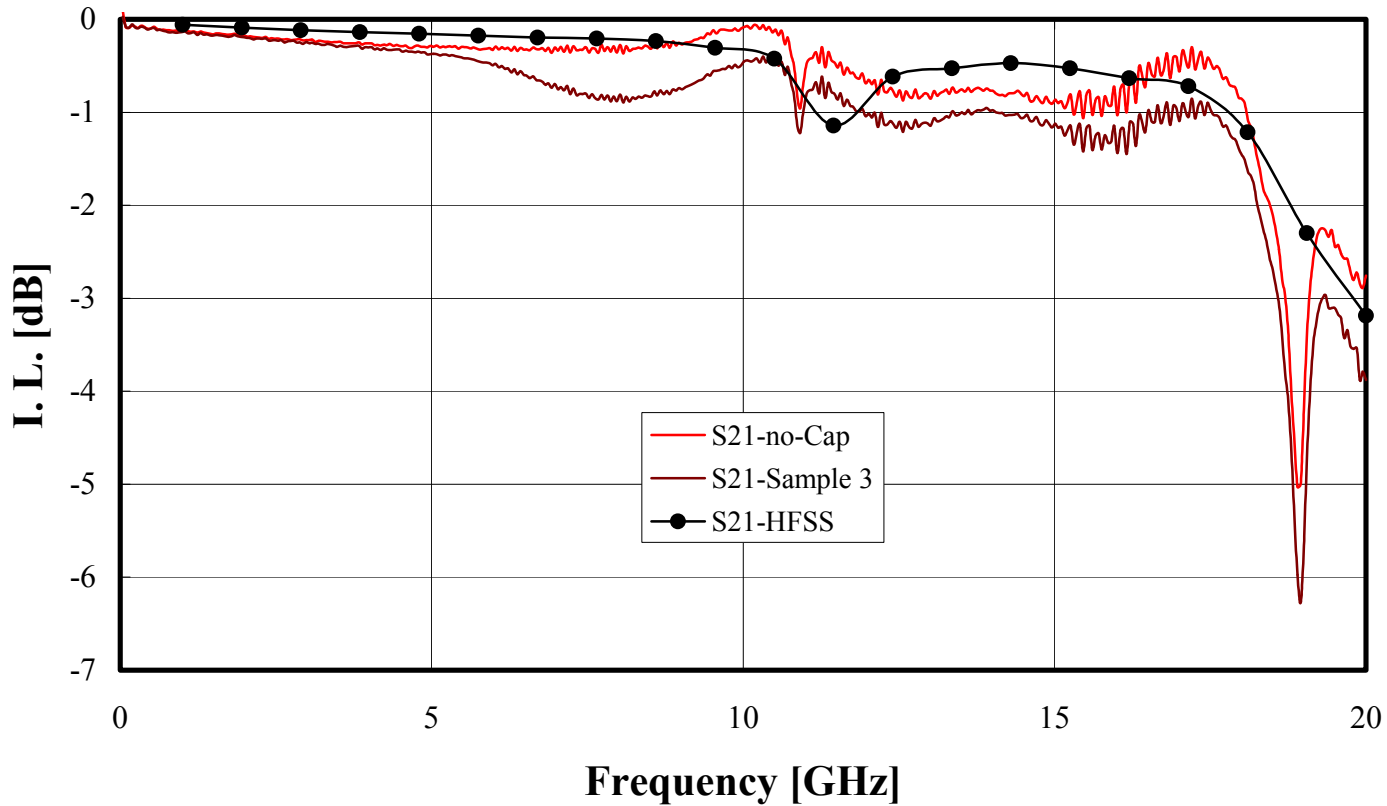

Your Strategic
EMS Partner



Material is property of BreconRidge
Copyright 2004

BreconRidge
Manufacturing Solutions

RF Carrier Containing a DC Block Capacitor Results Cont'd

ANSOFT HFSS Hfworkshop04

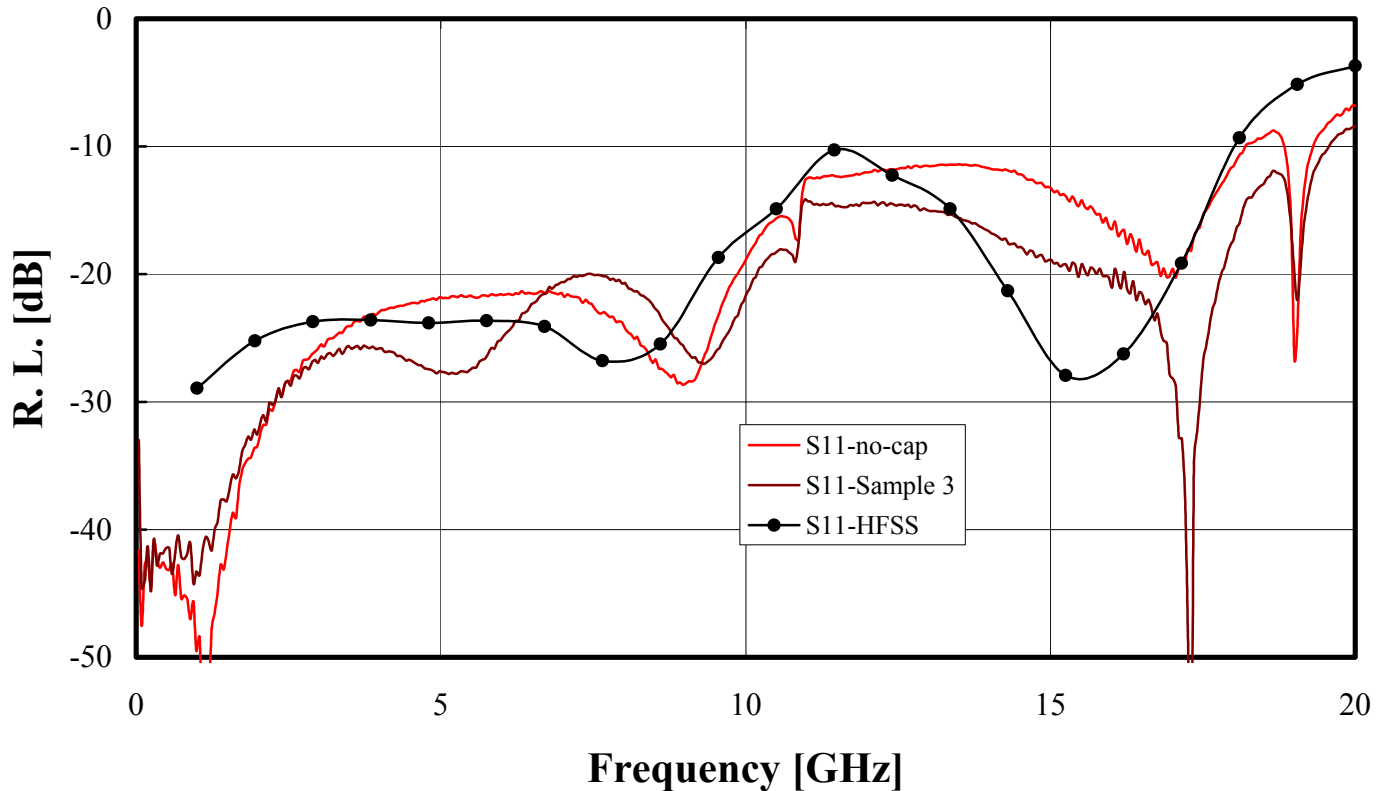

Your Strategic
EMS Partner



Material is property of BreconRidge
Copyright 2004

BreconRidge
Manufacturing Solutions

Ball Grid Arrays (BGA)

ANSOFT HFSS Hfworkshop04

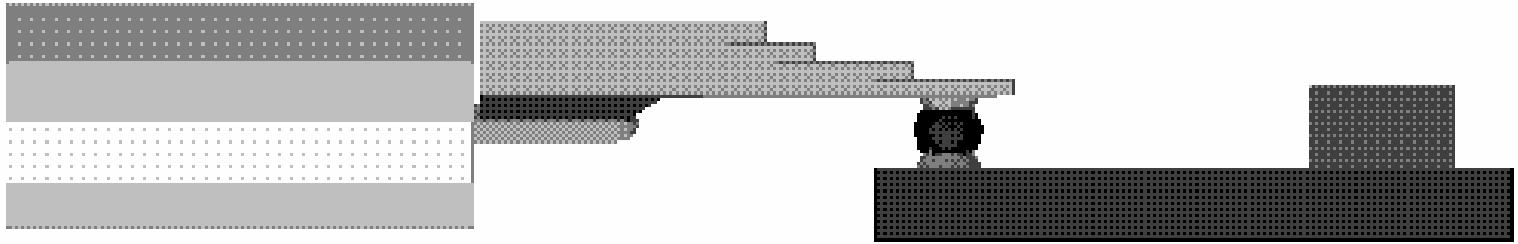

Your Strategic
EMS Partner



Material is property of BreconRidge
Copyright 2004

BreconRidge
Manufacturing Solutions

Conclusions

ANSOFT HFSS Hfworkshop04

- We presented a practical approach suitable for use in the design of high speed 10 and 40 Gb/s modules for sub-system applications.
- We demonstrated that stepping (tapering) the buried ground improves the electrical performance and reduced the size of the high speed modules.
- We employed this technique for different transitions.

Your Strategic
EMS Partner



Material is property of BreconRidge

Copyright 2004

BreconRidge
Manufacturing Solutions