



---

# Application of HFSS for Predicting and Eliminating Enclosure Resonances of RF Products

Ken Hersey  
QSS Group, Inc.  
under contract for NASA/GSFC  
March 2, 2005

# Purpose

---

- Detail a procedure for predicting and eliminating enclosure resonances in RF products
- Highlight a less common application of HFSS
- Illustrate various hints and tips to implement this technique

# Background

---

- A space-flight qualified 26.5 GHz Solid-State Power Amplifier (SSPA) is currently under development at NASA/GSFC
- Microwave Monolithic Integrated Circuit (MMIC) amplifiers, connected with microstrip transmission lines, comprise the key elements of the design

## Prototype Results

---

- Early prototype testing revealed a lower RF power output and higher DC current draw than expected
- Cavity resonances within the box were speculated as causing oscillations in some MMIC amplifiers
  - The MMIC device is pushed into saturation from the positive radiative feedback, thus increasing the DC current
  - Oscillations cause the amplifier to use some of its power gain towards undesired spectrum, thus reducing the expected RF power output
- Even though high dielectrics like Alumina and GaAs help to constrain the fields, discontinuities (which radiate) such as bond wires can exacerbate the excitation of cavities resonances

# Plan of Action

---

1. Minimize all cavity sizes to reduce resonances
2. Modify remaining larger cavities to minimize resonances, within mechanical constraints
  - BUT WITH WHICH METHODS?
    - Absorbers
    - Walls
    - Septums
    - ???
- To determine the optimum mitigation techniques for this application, HFSS was used to
  - Analyze the cavity structure with various treatments
  - View 3D field plot results to guide our choices

## Example Cavity

- One of the remaining larger cavities was selected for analysis
  - 0.5" x 0.83" x 0.1" (L x W x H)
- The main RF chain aligns through the selected WavePorts
- Microstrip input/output is on Alumina
- MMIC is represented as GaAs substrate with a 50 ohm trace
- L-shaped cavity contained DC bias circuitry, also on Alumina

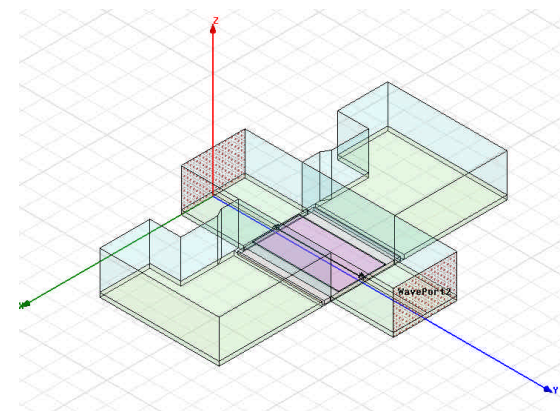
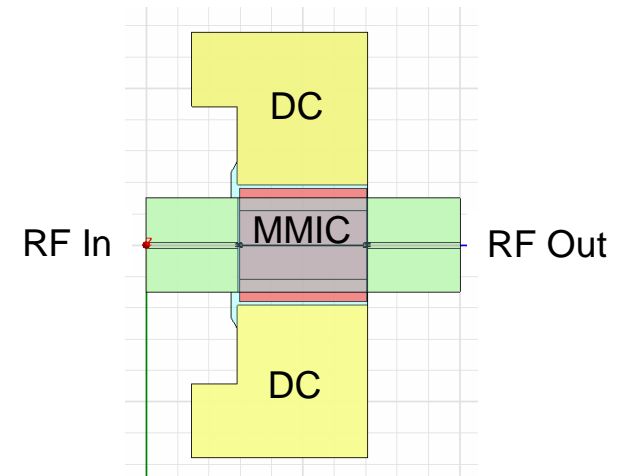

# HFSS Model Description

- Symmetry in H-plane was leveraged for a quicker solution
- WavePorts bounded the 50  $\Omega$  microstrip through line
  - Alumina-GaAs-Alumina substrate path
  - Through line represents a reasonable simulation of the application
  - We neglect amplifier gain, and just look for cavity resonances
- Bond wires of similar geometry were created, as used in the application, between substrates
- DC parts and traces were not modeled – negligible effects

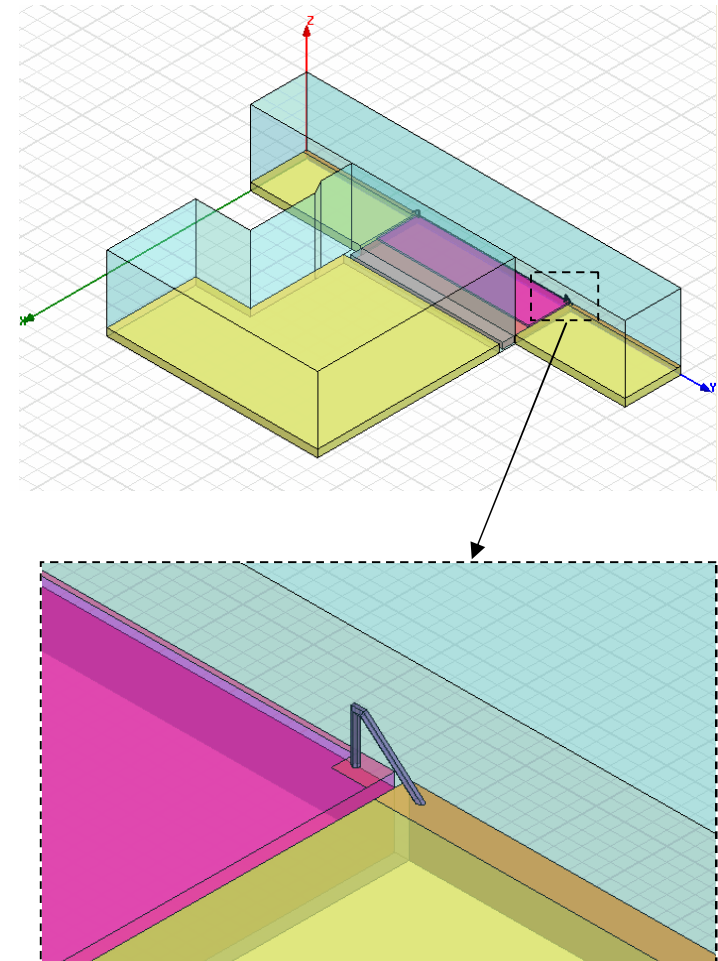

# HFSS Analysis Setup

---

- Adaptive analysis at center frequency
- Don't forget to "Save Fields"
- Sweep across entire MMIC frequency response, since out-of-band resonances can also reduce desired output
  - a) Discrete Sweep
    - Slower analysis for many frequency points
    - Quicker animation generation
  - b) Fast Frequency Sweep
    - Quicker analysis for many frequency points
    - Slower animation generation
      - HFSS will have to retrieve data from many data files and perform "Fast Sweep Field Configuration" for each animation frame since only the S-parameters are saved per fast frequency point

# HFSS Results Procedures (1)

---

- Field Plot Results
  - Select all model objects (or just the cavity) and plot Mag\_E
  - Manually force a lower V/m scale, perhaps 1000 V/m
  - Define a frequency animation
    - Use the same solved frequencies, if a discrete sweep was used
      - These will probably differ from the default values for “Freq”
    - “Steps” is 1 less than “Count” (from frequency sweep setup)
  - Examine cavity of frequency for resonances (cavity will “light up” all red)
  - Stop animation playback at resonant frequencies
    - Zoom, rotate, and pan in real-time to identify the issues!
  - You must regenerate all frames again to re-view a closed animation
    - Consider exporting important results to movie files

## HFSS Results Procedures (2)

---

- S-parameter Results
  - Examining discontinuities in the S21 and S11 responses can also be instructive
  - Enclosure resonances will appear as sharp changes in S21 and S11 vs. frequency
  - May be a reasonable way to efficiently use the fast frequency sweep for this application
    - However, it doesn't identifying the specific problematic locations
  - Still can use with a discrete frequency sweep
    - The relative change in S-parameters can help quantify the performance of a trial solution compared to other solutions

## Mechanical Constraints

---

- Several constraints prevented using the baseline 150 x 100 mil RF channel throughout the SSPA
  - DC components
  - DC traces
  - DC bond wires from capacitors to the MMIC
  - Bias bulkhead feed-through pins
- Ease of manufacturing preventing sub-sectioning of the Alumina DC substrate
  - All methods must attach to the lid
  - Metallic contact from the lid to the floor was prevented

# Initial Configuration Results (1)

- A strong resonance within the enclosure was found at about 25 GHz
- Mode is set up between opposing far walls of DC cavities

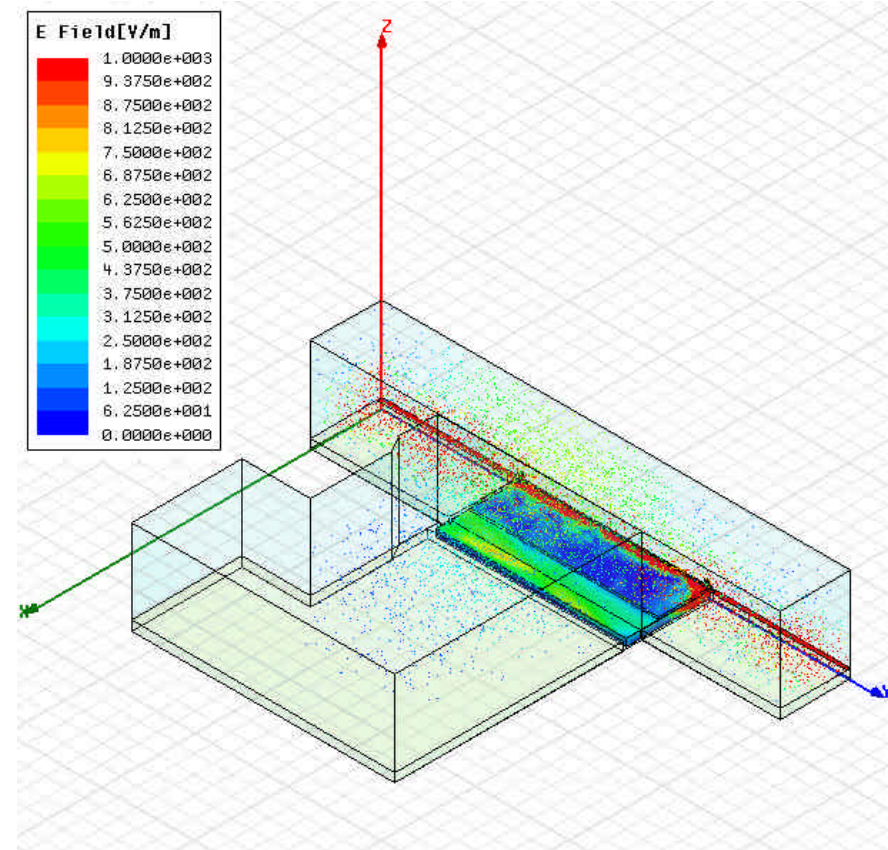
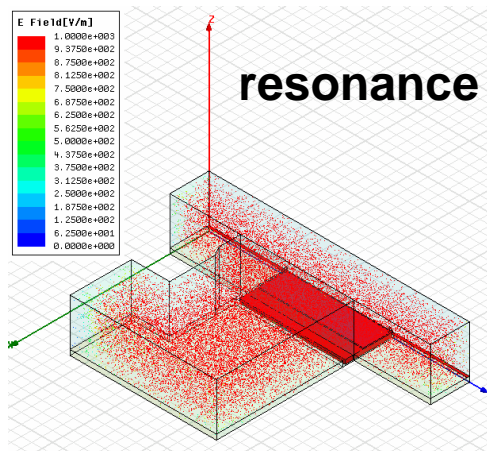

**Frequency animation of Mag\_E**

## Initial Configuration Results (2)

- Enclosure resonance confirmed through S-parameters
- Note that this resonance was “out-of-band,” yet impacted performance of the circuit

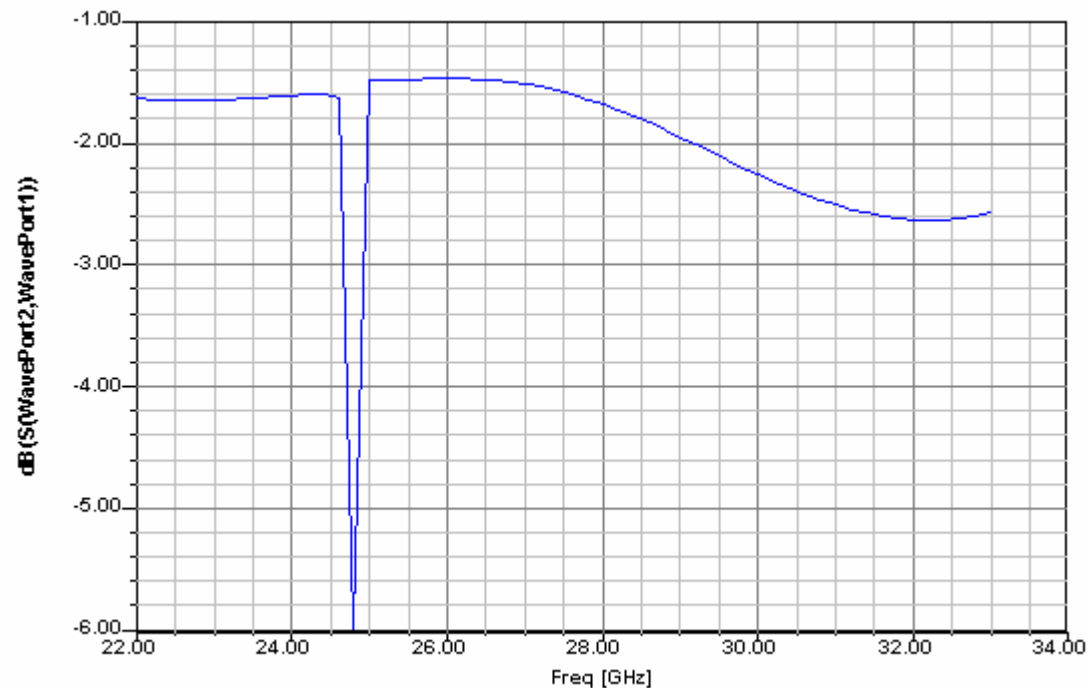

# Proposed Solutions

---

- Method 1: Provide a “garage-door” to close off the DC cavities
  - Worked for RF, but interfered with DC bond wires
- Method 2: Place absorber in DC cavity
  - Not enough cavity space to reduce modes – still resonated in remaining space below absorber
- Method 3: Insert septum through DC cavity, from lid
  - Final chosen implementation

## Final Configuration Results (1)

- Sealed off bottom with compressible conductive absorber, contacting via pins to enclosure ground
- Small notch for DC traces
- Acceptable compromise between RF and mechanical

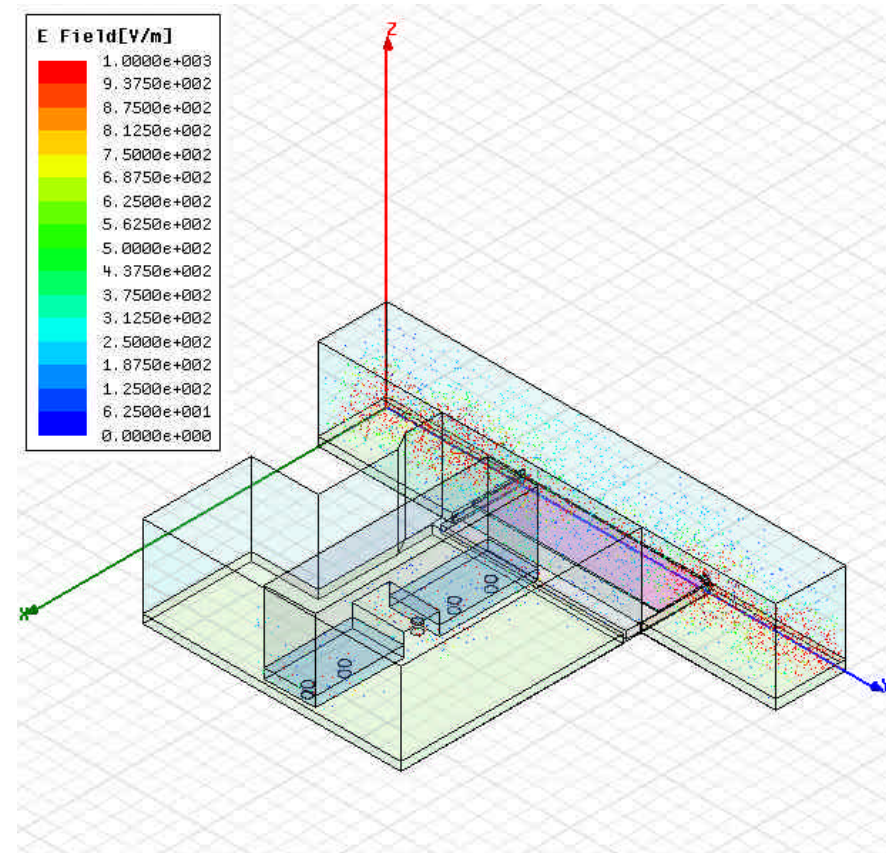

Frequency animation of Mag\_E

## Final Configuration Results (2)

- Enclosure resonance mitigation confirmed through S-parameters

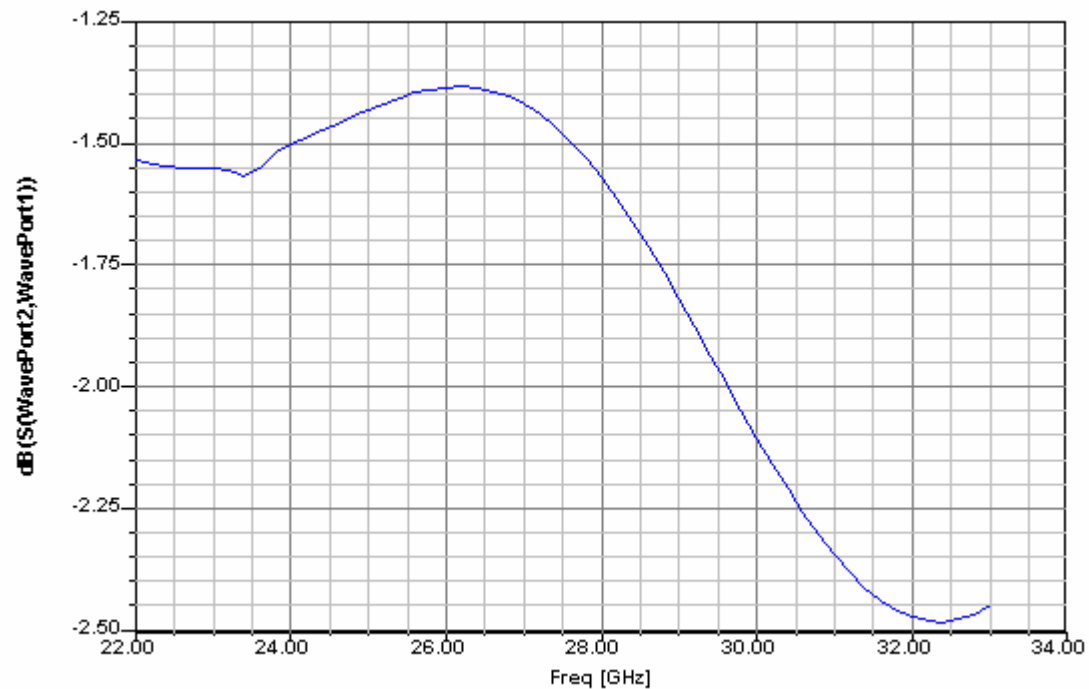

## Conclusions

---

- HFSS provided a quantitative tool to direct our choices to mitigate enclosure resonances
- Compromises between RF and mechanical packaging could be evaluated before any additional fabrication
- Implementation of the recommended solution successfully eliminated the resonances in the enclosure, enabling the expected performance