

Fluxgate Sensor Analysis

Dennis Steward
EM Application Engineer
Ansoft Corporation
Pittsburgh, PA

Flux Gate Sensor Basics

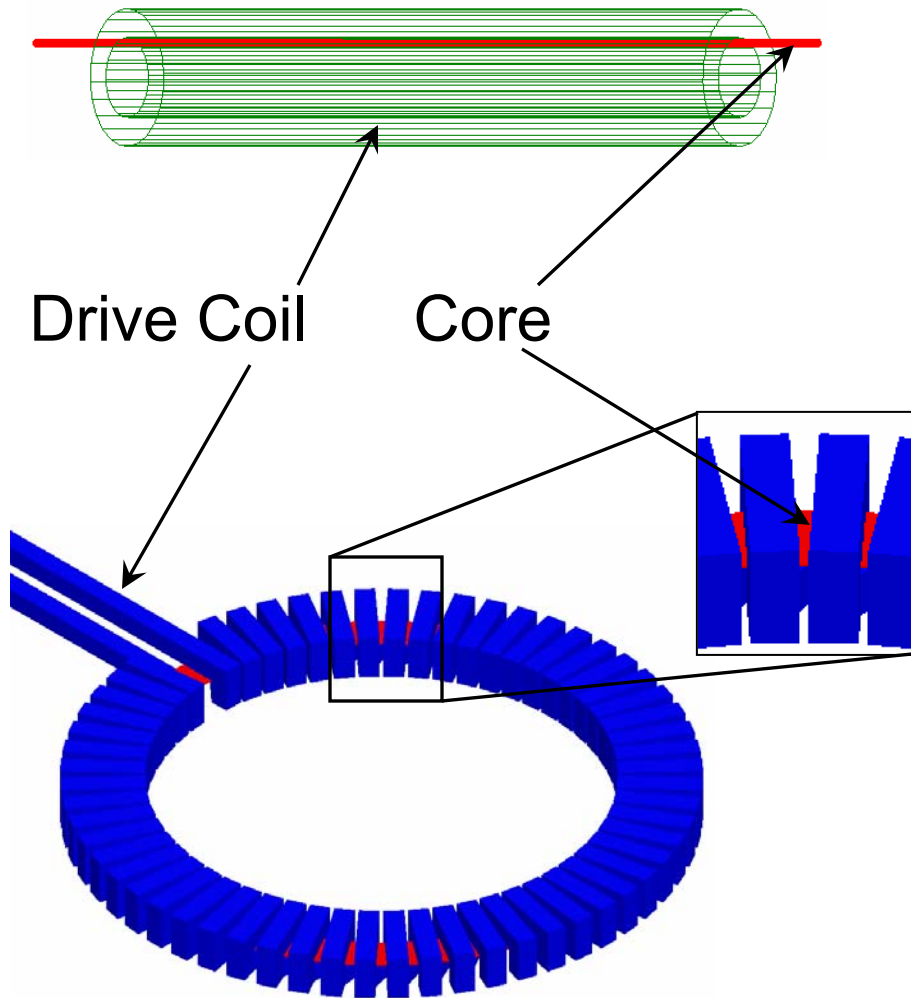

- ▶ Simple Construction
 - ▶ Easily Saturable Core
 - ▶ Drive Coil
- ▶ Variable Inductance
 - ▶ Function of Drive Current
 - ▶ Function of External Magnetic Field

Flux Gate Sensor Basics

Typical B-H Curve

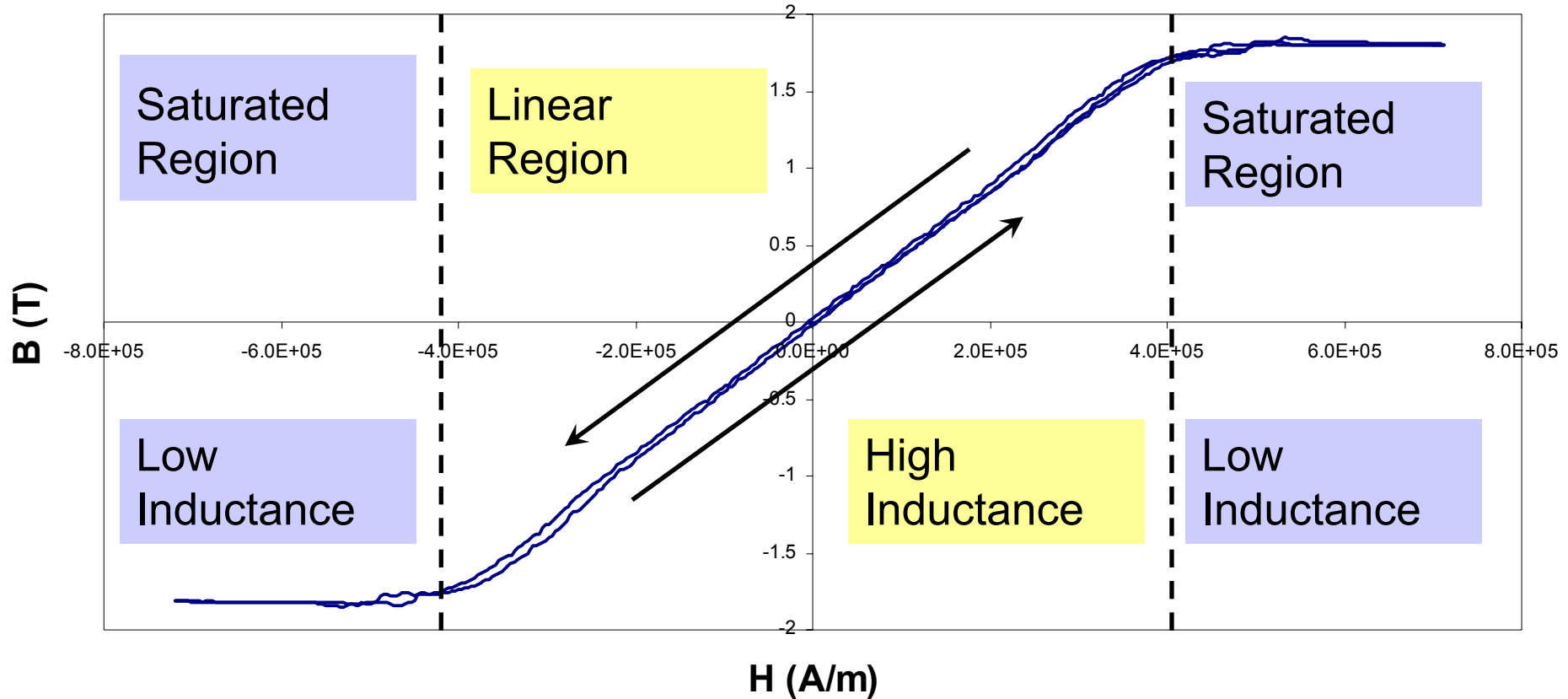

Sensor is Driven Between Linear and Saturated Regions of the B-H Curve

Flux Gate Sensor Applications

- ▶ Typical Flux Gate Sensor Applications include:
 - ▶ Proximity Sensing
 - ▶ Magnetic Field Measurement (Navigation, Geomagnetism)
 - ▶ Speed & Position Sensing
- ▶ Sensor has Linear Response Characteristic

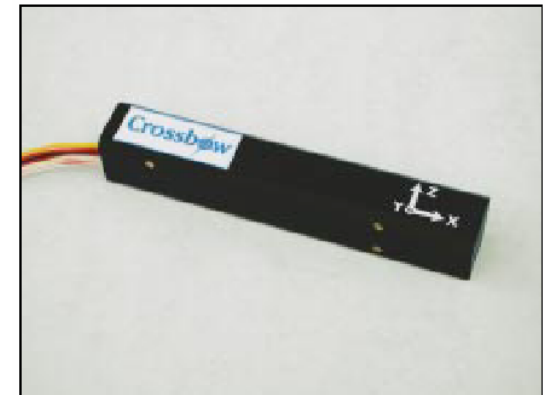
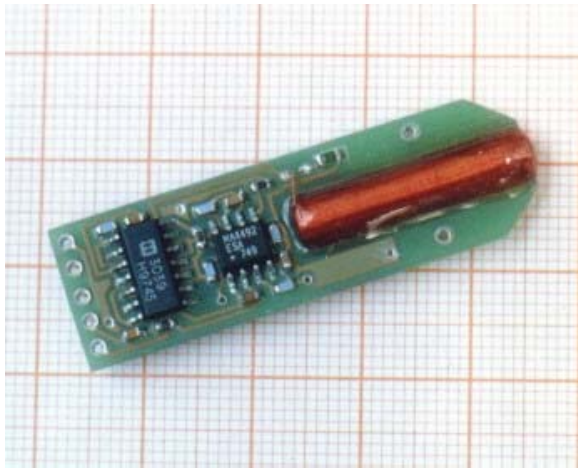

Maxwell Setup

How do I model a Flux Gate Sensor Using Maxwell?

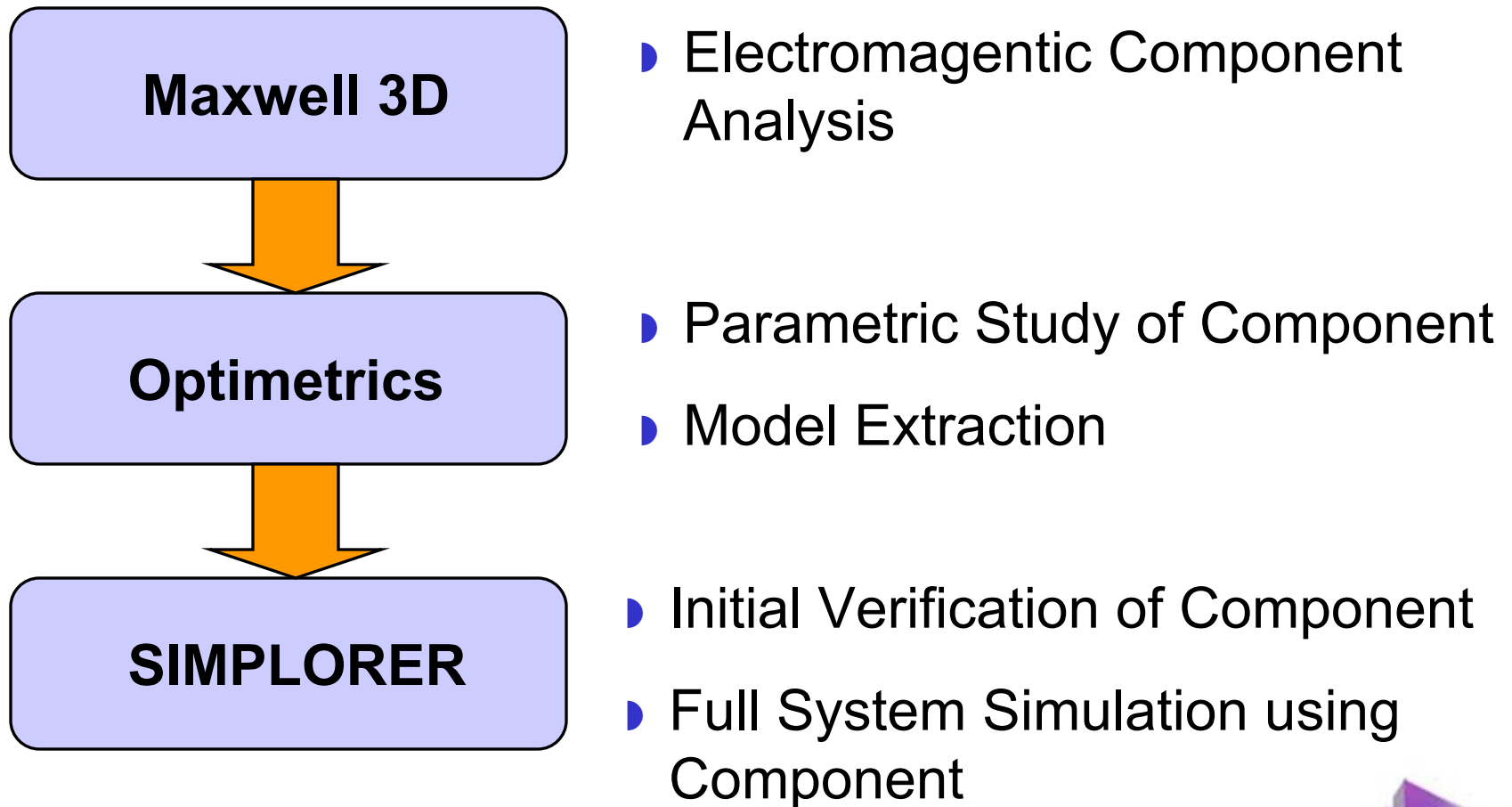

Parametric Analysis

Inductance Variation of Flux Gate Sensor

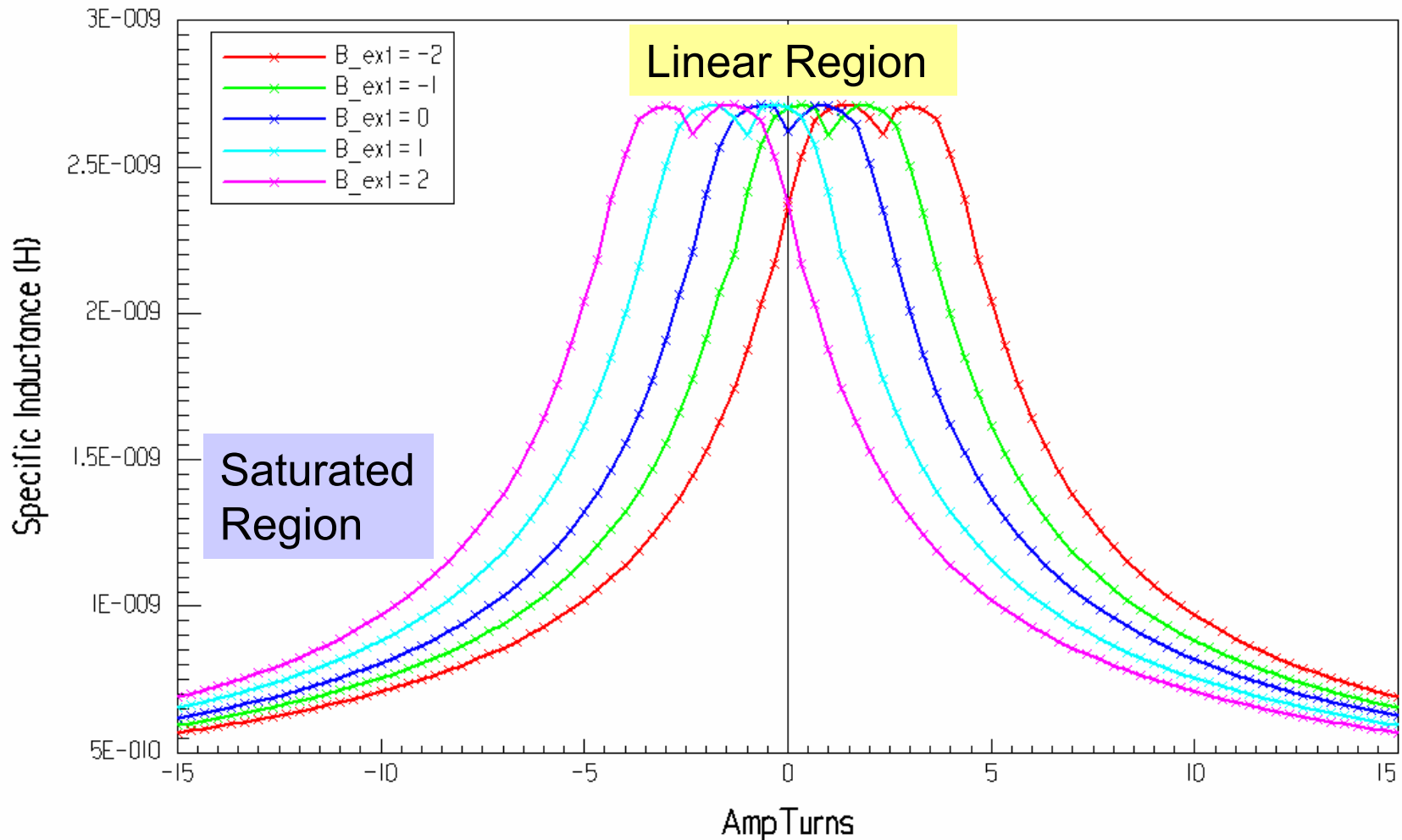

- Curve Shifts Due To Influence of External Field

Export Component Model

▶ Model Type

▶ Coil Parameters

▶ Extra Port (B_z)

Model: Parameterized Model

Format: Simplorer Use Model Picture

Notes:

Table File: Read Table... File Name: sat_core_refined_v9

Type: Matrix Electric Model Units: mils
 Magnetic

Interpolate: Bezier on All

Depth: 1 mils

Conductor	Turns	Resistance	Current
coil	500	0	AmpTurns

Turns: 500
Resistance: 0
Current: AmpTurns

Extra Ports

Use	Name	In/Out	Extrapolate	Units
No	AmpTurns	Input	Linear	N/A
Yes	Bz	Input	Linear	N/A
No	L[coil,coil]	Output	N/A	N/A
No	Energy(J)	Output	N/A	N/A
No	Error (%)	Output	N/A	N/A

Extrapolate: Linear

Component Analysis

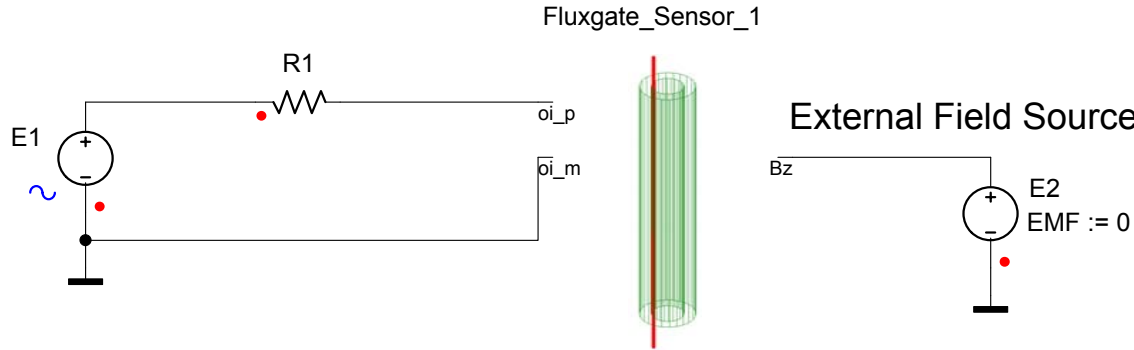

- ▶ **Waveform Distortion Caused by traversing the B-H Curve**

Sensor Current Response to a 2.5V, 100kHz Sinusoid

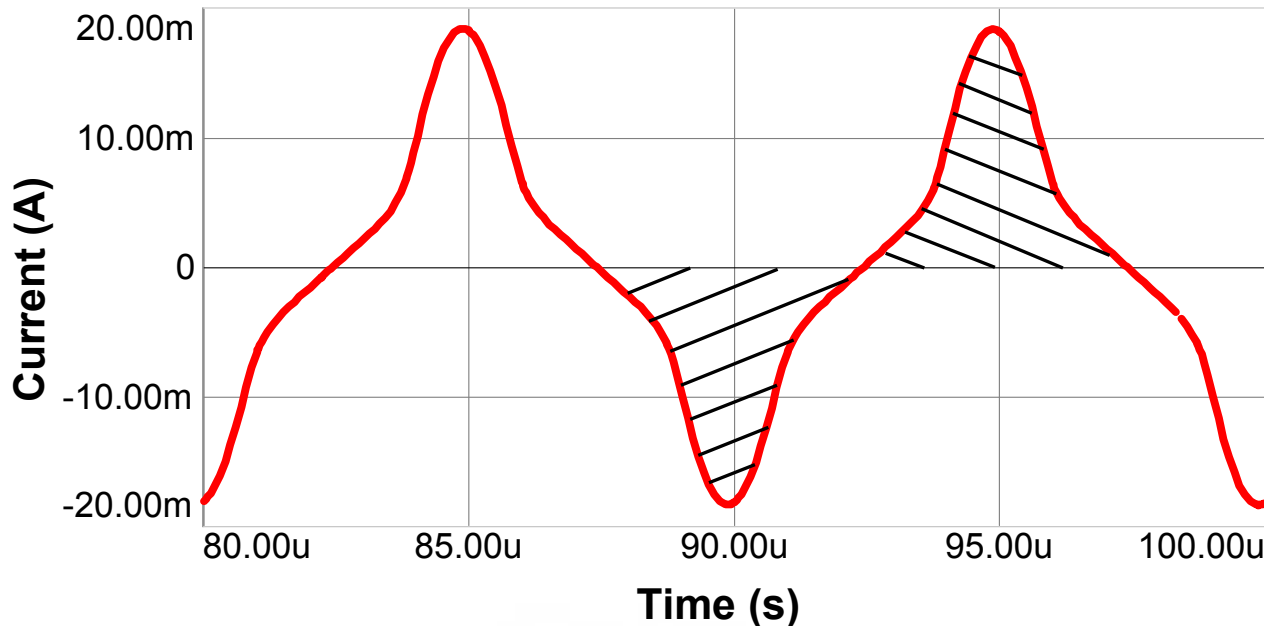

- ▶ **Positive and Negative Areas are Equal**

Component Analysis

- External Field Shifts Curve Positively or Negatively
- Positive and Negative Areas are No Longer Equal

Sensor Current Response to a 2.5V, 100kHz Sinusoid w/ External Field

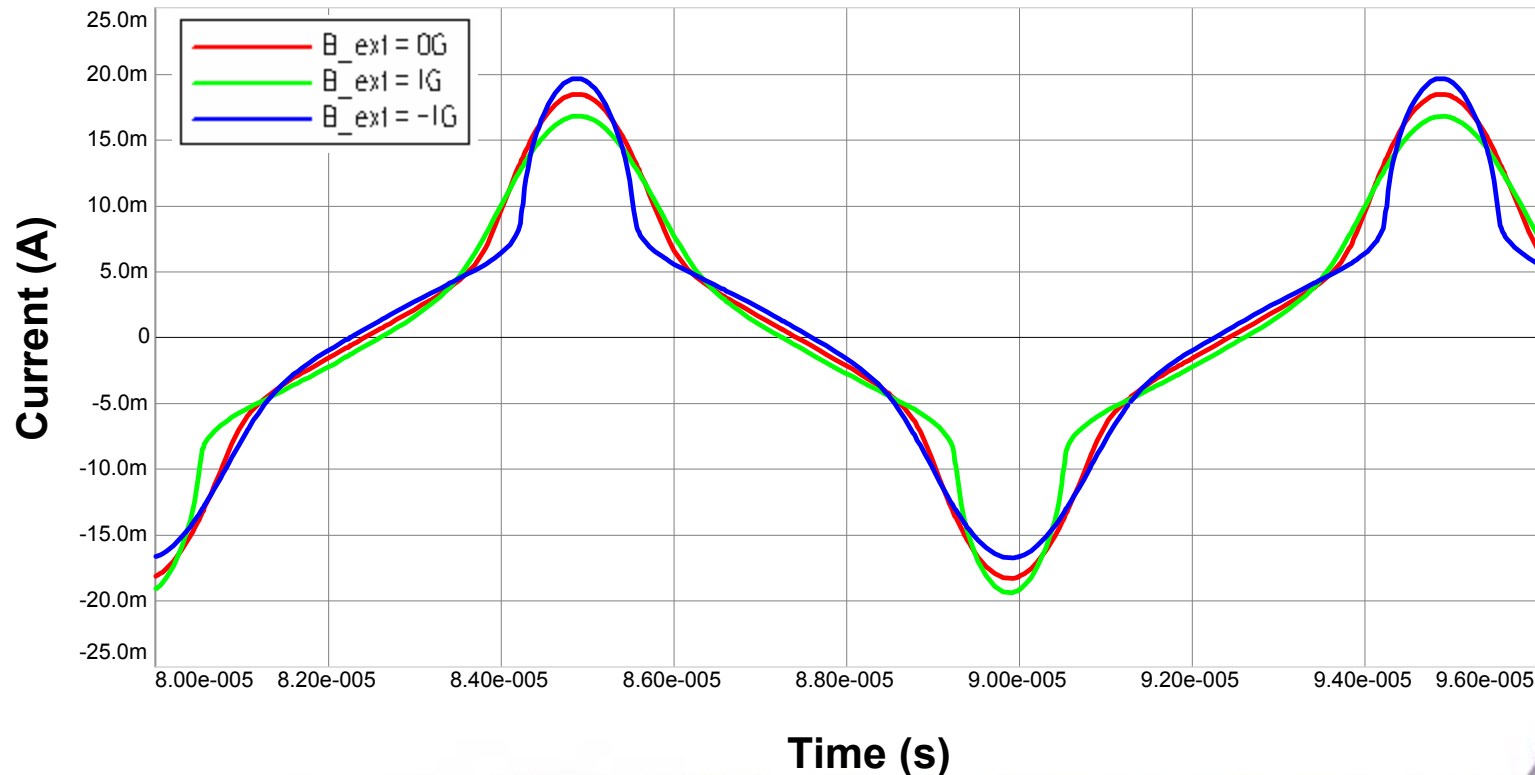

Component Analysis

Sensor Current Response to a 1.5V, 100kHz Sq. Wave w/ External Field

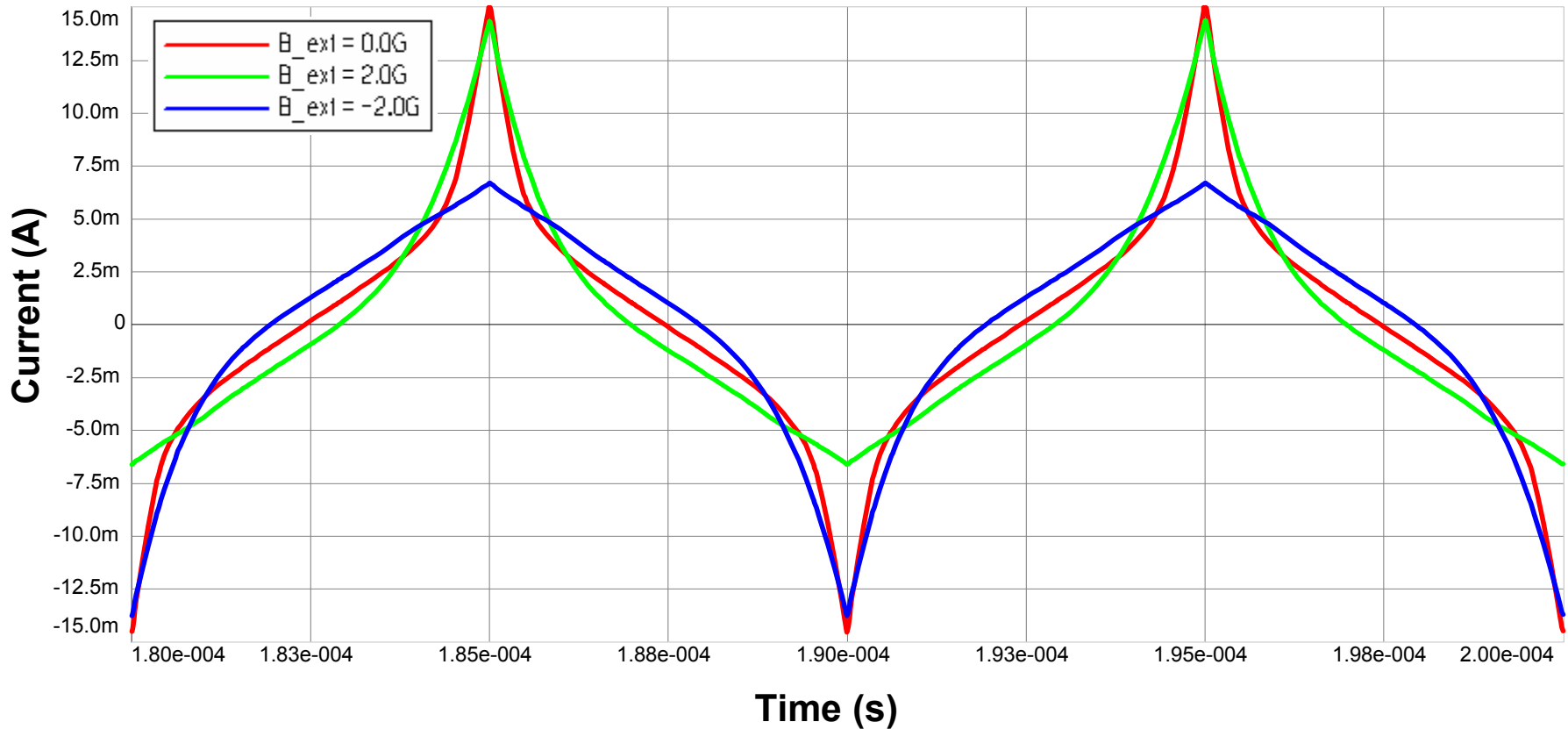

- ▶ Sensor Behaves Similarly When Excited With a Square Wave

Component Drive Signal

- Three State Drive

- 5V
- Ground
- Float

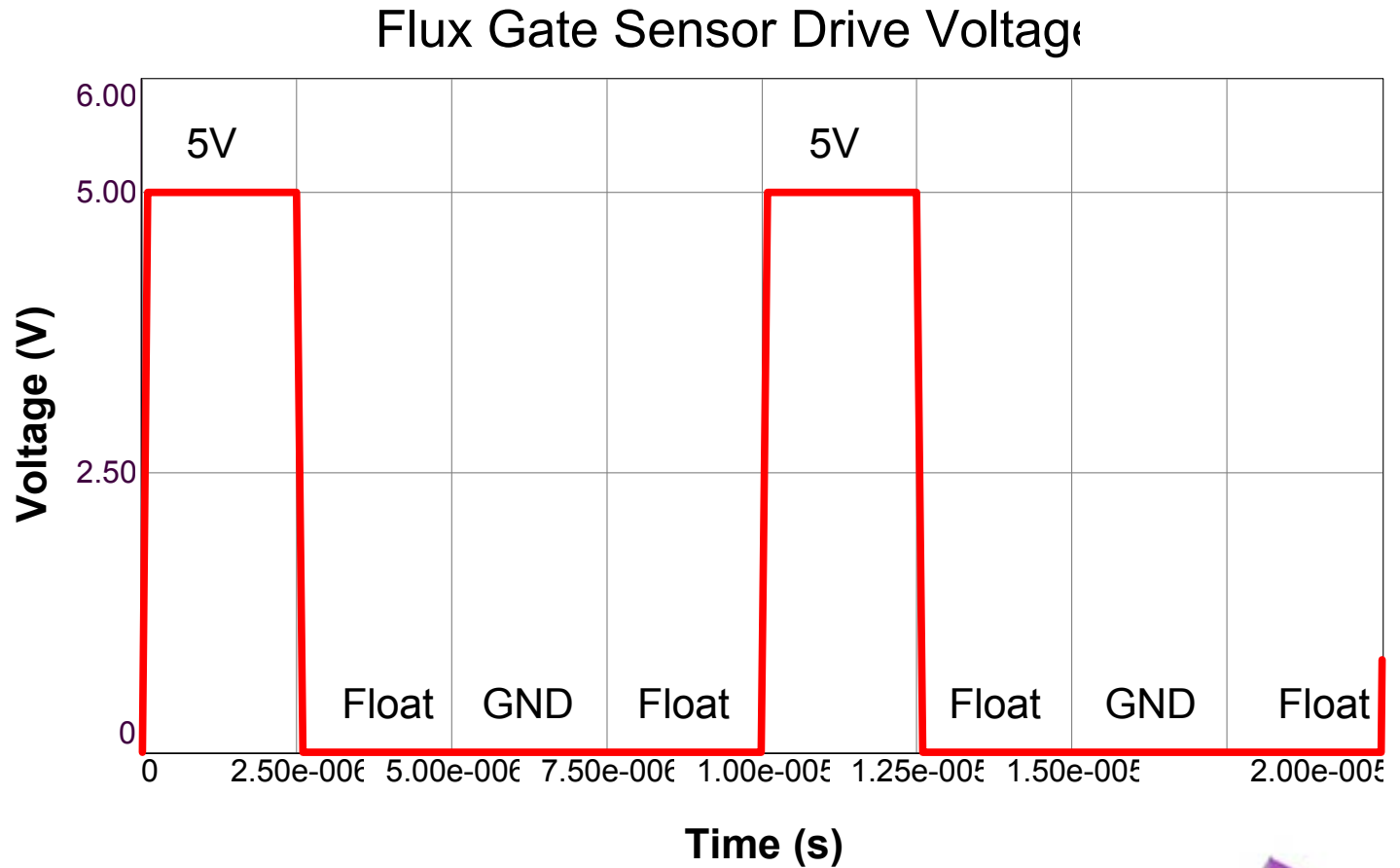

Component Drive Circuit

- ▶ Drive Circuit Implementation
- ▶ 2 MOSFETS Are Fired alternately to create the 3 States for the Flux Gate Sensor

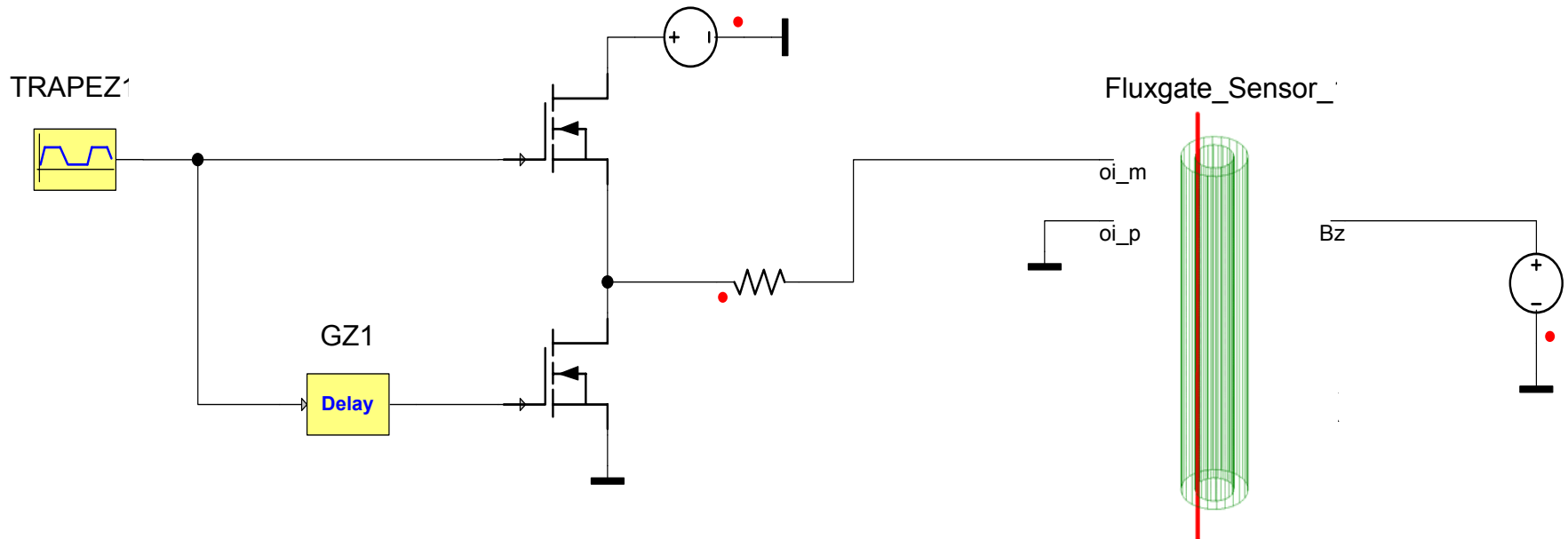

System Analysis

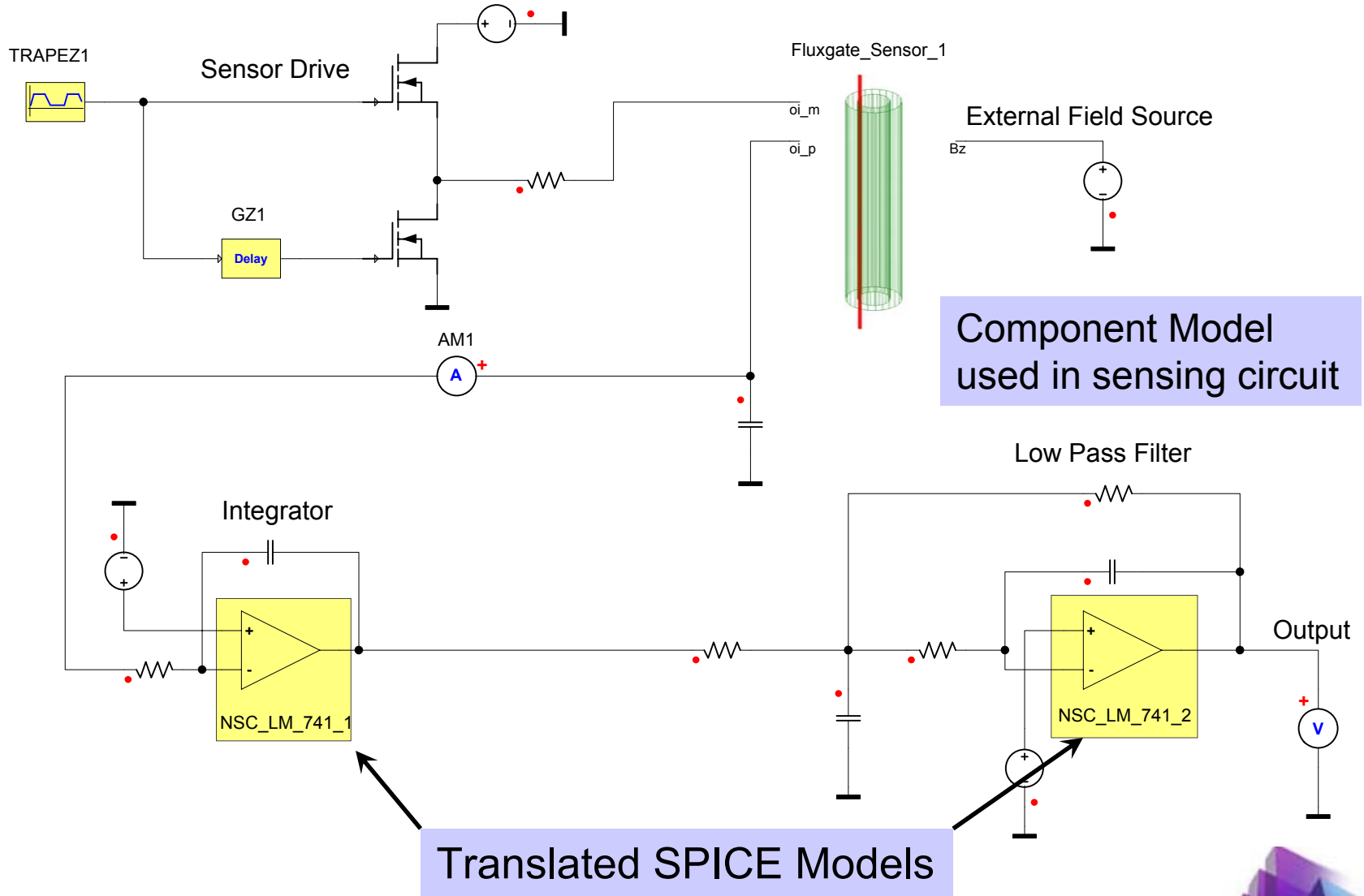

System Analysis

- System Output Voltage is Proportional To Magnitude of External Field

Flux Gate Sensor System Output Voltage

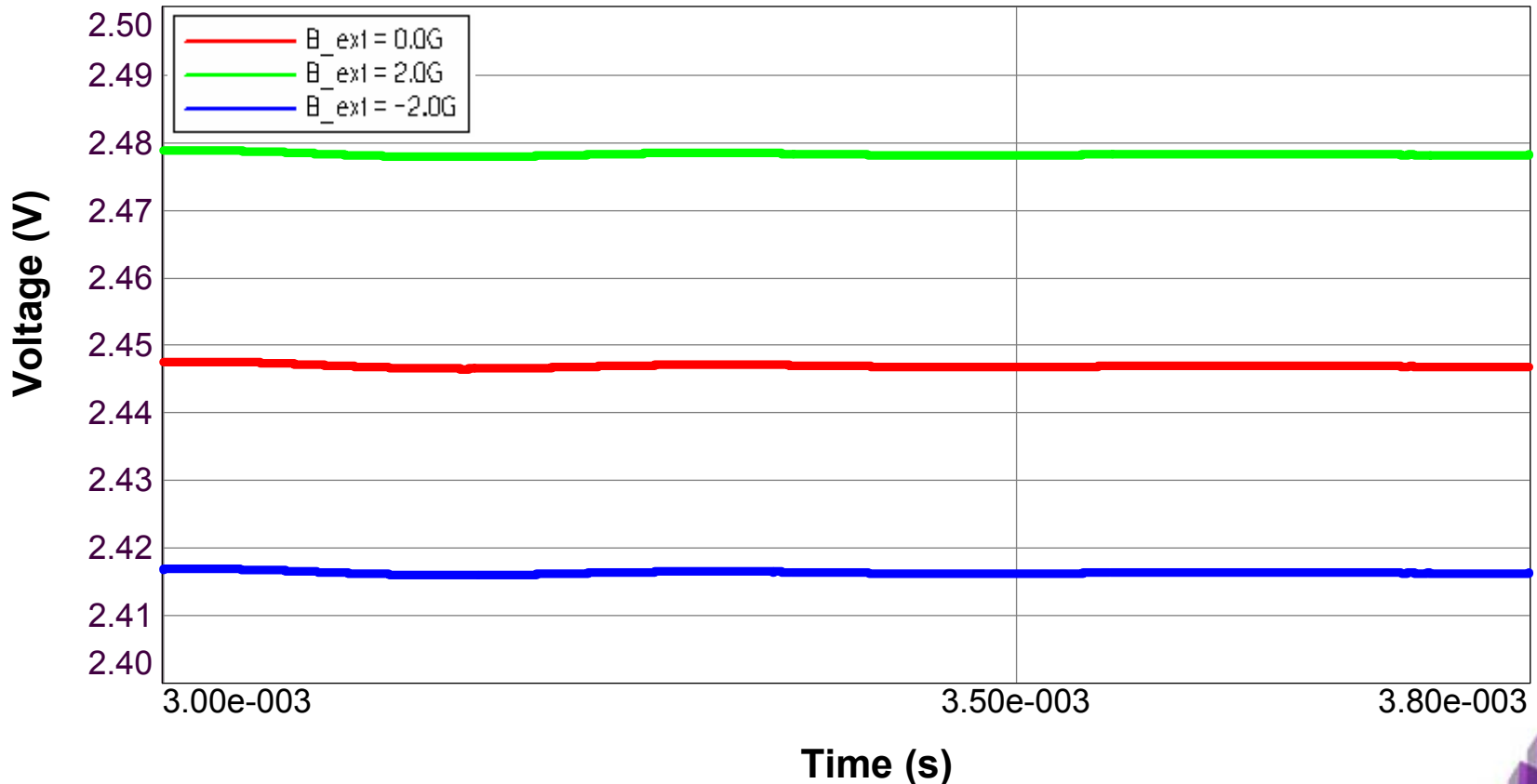

System Analysis

Final Differential Flux Gate Sensor Circuit Model

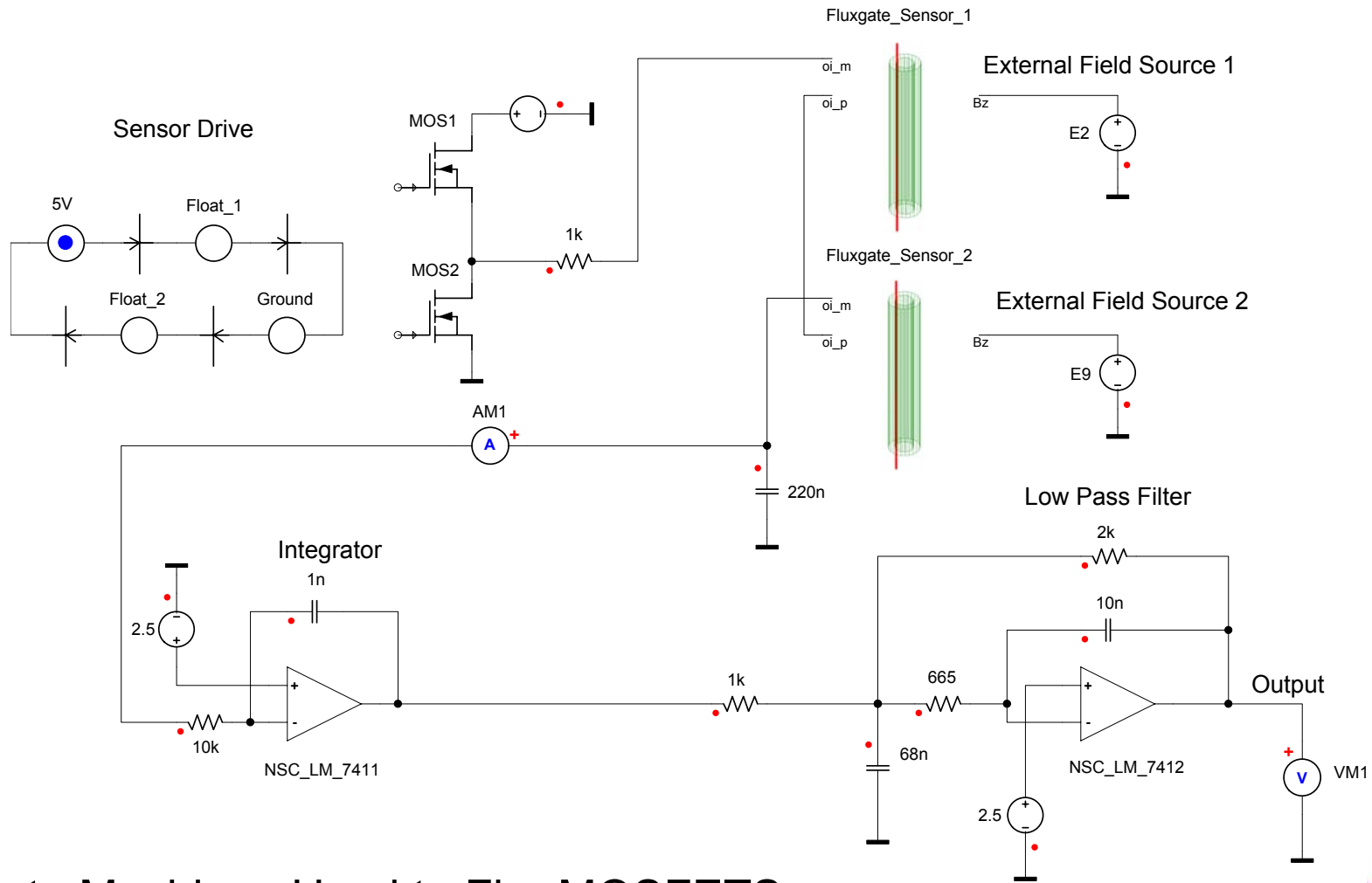

- State Machines Used to Fire MOSFETS

System Analysis

- ▶ Differential Sensor Response
- ▶ External Field For Sensor 2 Changes from 0G to $-2G$ at 2ms
- ▶ Output Voltage Shifts Downward to Reflect the Change

Differential Flux Gate Sensor System Output Voltage

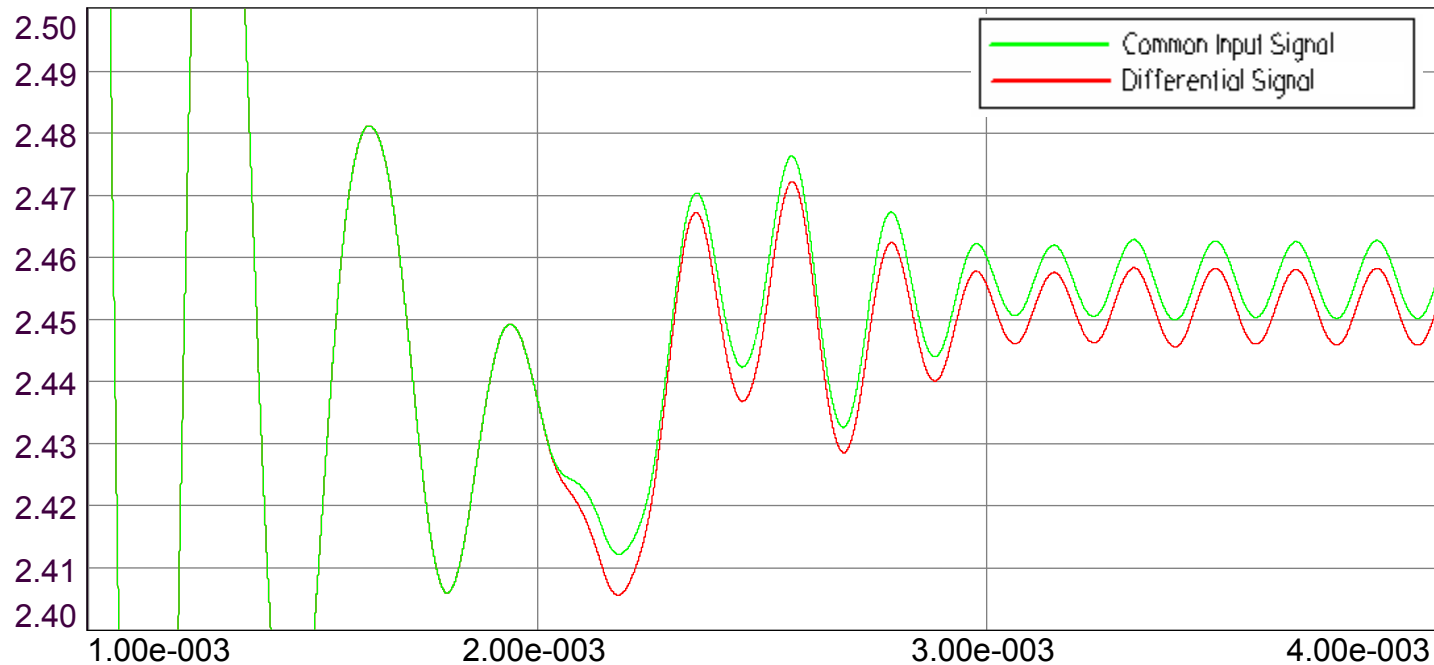

Conclusions

- ▶ Using Maxwell 3D and Optimetrics, the electromagnetic behavior of a Flux Gate Sensor may be accurately analyzed.
- ▶ A component model may be extracted from the Finite Element Analysis which may then be used to examine the impact of the component within a larger system.
- ▶ SIMPLORER provides an environment where the finite element component model may be combined with circuit, block diagram, and state machine elements to study the role of the component in a complete system.