

Modeling Frequency-Dependent Effects in the Time Domain

Mark Christini, Mark Solveson
Ansoft



Acknowledgments

Siemens for supplying measurements of coaxial cable used for verification of simulations and for supplying schematic for Maxwell 2D transient simulation.

The word "SIEMENS" is displayed in a bold, teal-colored, sans-serif font, centered on the page.

Presentation Goals

- Introduction of frequency-dependent modeling challenges.
- Discussion of three methods for creating frequency-dependent models.
- Calculate and verify R,L,C,G parasitics for a specific coaxial cable example.
- Creation of frequency-dependent model using Q3D.
- Simulation of cable model in Simplorer.

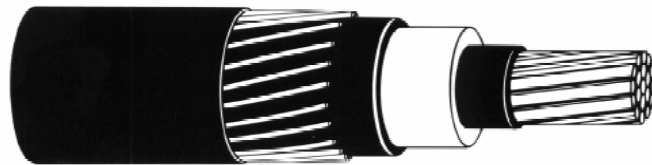
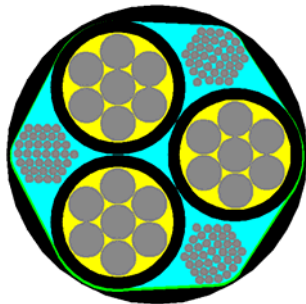

Introduction

- The need to fully understand how devices operate through the desired frequency spectrum has increased due to:
 - the trend to operate devices at higher frequencies
 - the increased use of inverter power supplies which cause non-sinusoidal voltages, currents, and extra losses
- Products such as cabling, bus bars for power delivery, signal interconnects, and integrated power-electronic modules exhibit frequency-dependent behavior due to eddy current and skin effects.
- In these cases, it may not be sufficient to rely on resistance and inductance extracted at a single operating frequency.

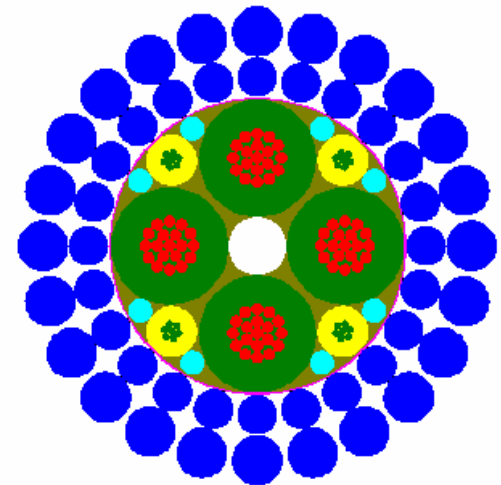
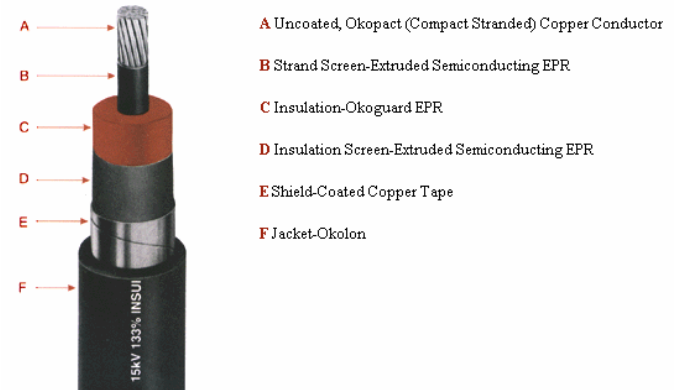

Introduction

- This presentation will demonstrate how **Q3D** and **Simplorer** can be used to easily simulate cable models in the time-domain.
- Three different methods used for cable modeling will be reviewed.
- Traveling waves, over-voltages, and resonant frequencies will be determined using a frequency-dependent cable model.



Q3D Overview

- Q3D is a tool streamlined for quickly characterizing electrical parasitics of interconnect structures.
- Q3D includes:
 - Q3D Extractor: 3D quasi-static lumped RLC parameter extractor. Linear permeability = 1.
 - 2D Extractor: 2D T-line RLGC parameter extractor. Linear permeability.

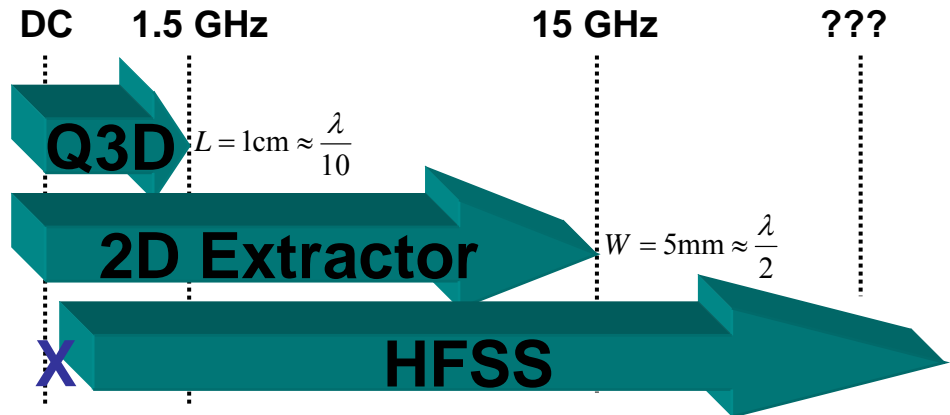
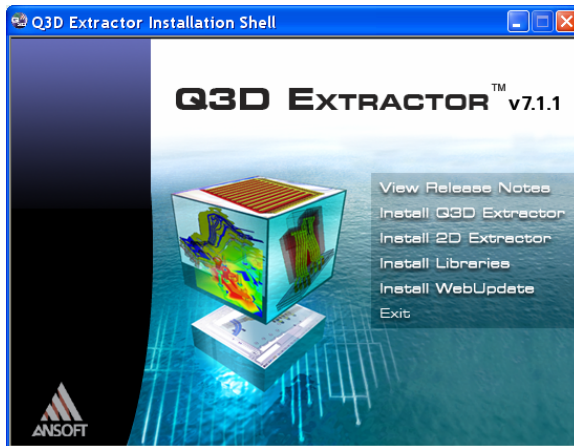

Three Cable Modeling Methods

1. Lumped, frequency-independent, hierarchical structure model in Simplorer.
2. Lumped, frequency-dependent model in Maxwell 2D transient using external circuits.
3. Lumped, frequency-dependent model exported from Q3D into Simplorer.

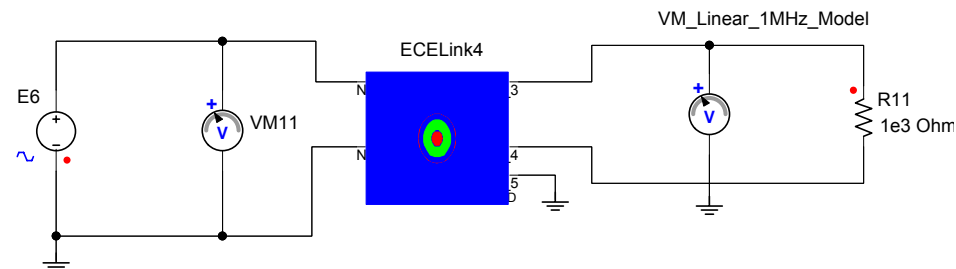
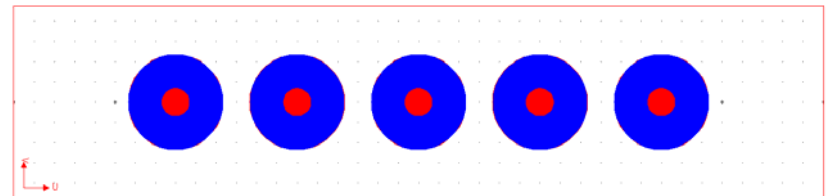
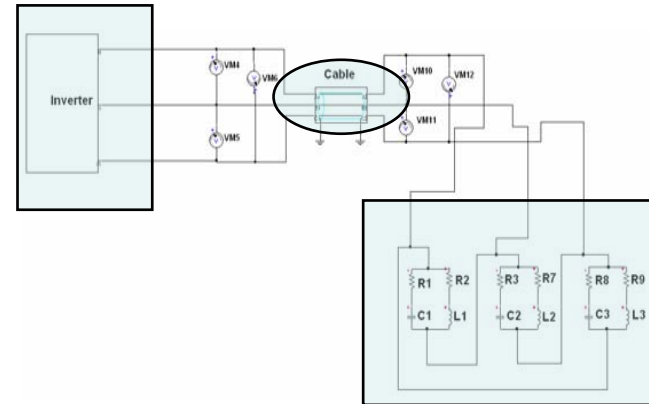

Method 1: Lumped, Frequency-Independent, Hierarchical Structure

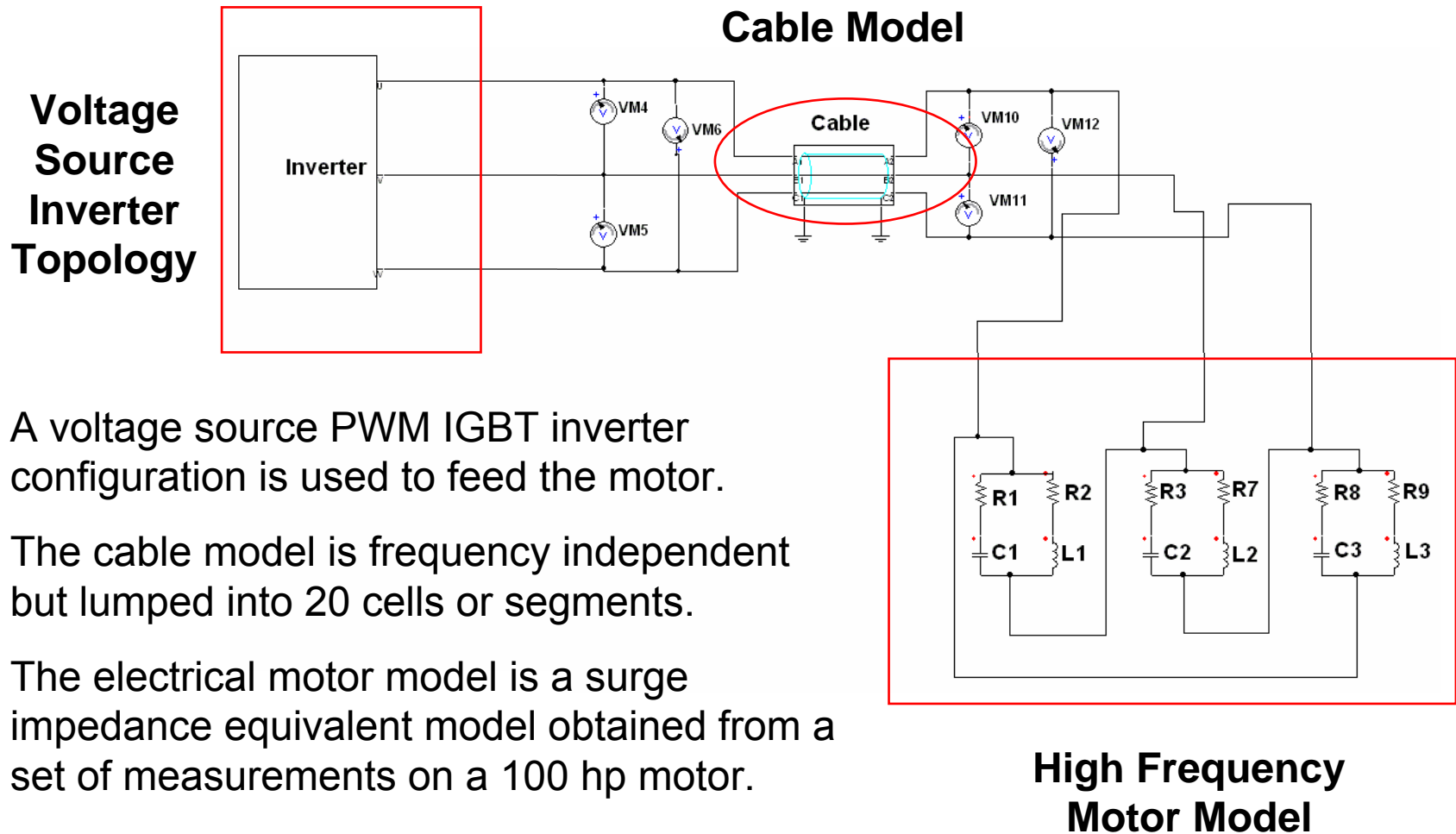

Method 1: Lumped, Frequency-Independent, Hierarchical Structure

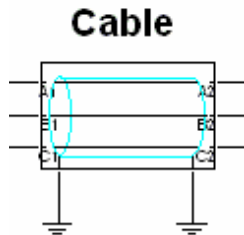

R,L,G,C

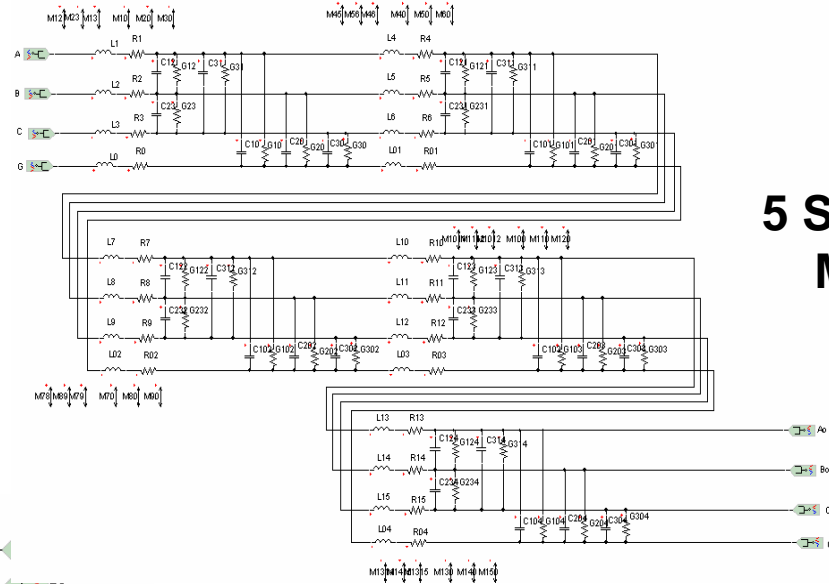
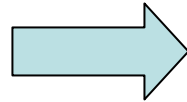

5 Segment Model

20 Segment Model

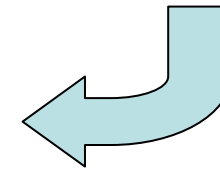
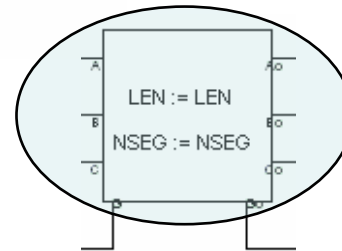
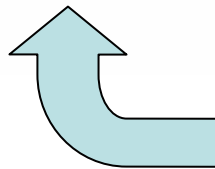
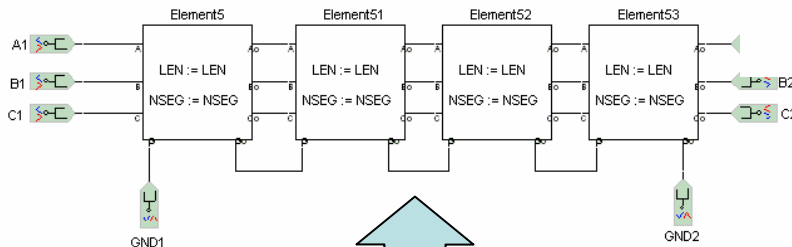

Method 1: Lumped, Frequency-Independent, Hierarchical Structure

- Voltage results shown for varying cable length.
- Traveling wave over-voltages and resonant frequency vary with length.
- Considerations:
 - Model is manually constructed.
 - Model is frequency independent.

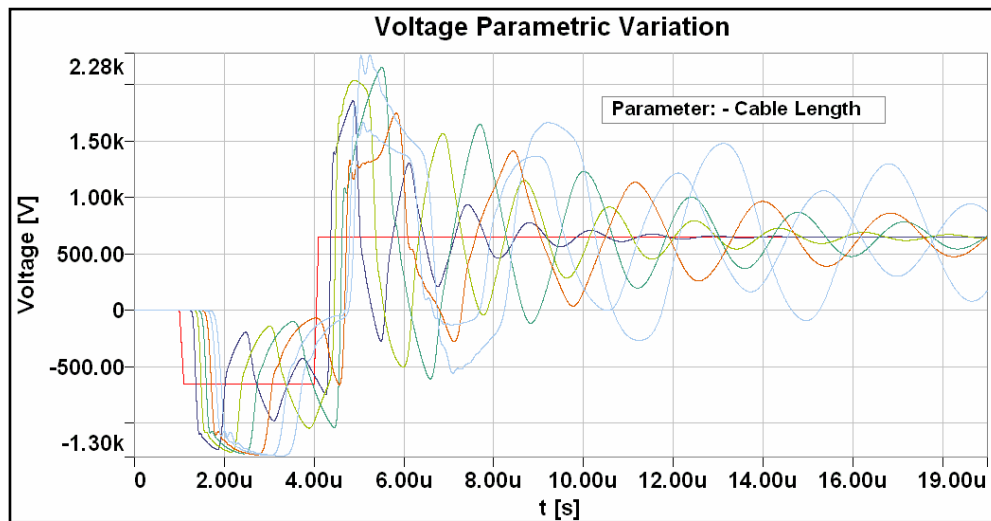

Method 2: Lumped, Frequency-Dependent Model using the Maxwell Transient Solver

- Use Maxwell 2D transient with series of independent coaxial models in one FEA solution (assumes no coupling occurs).
- Connect in lumped network in 2D transient external circuit.
- Add in shunt capacitance from 2D electrostatic simulation.

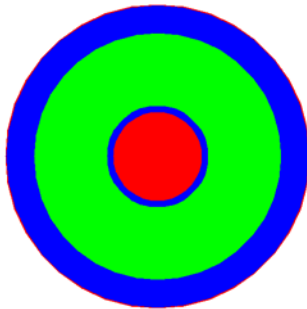
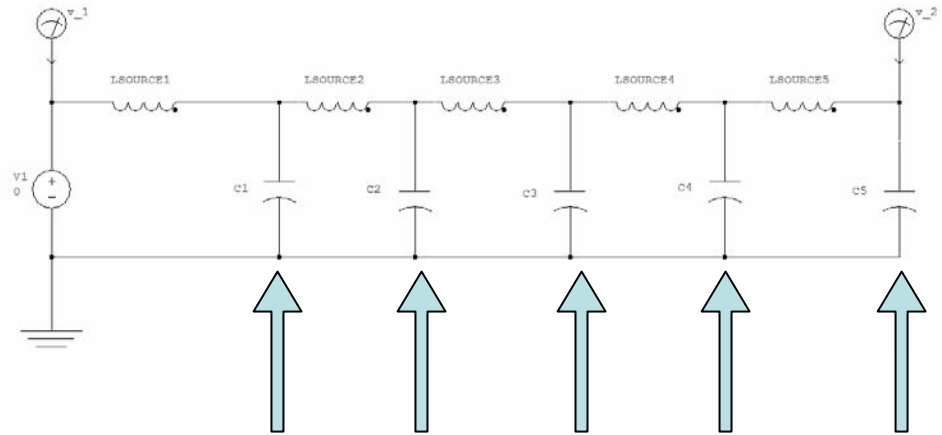
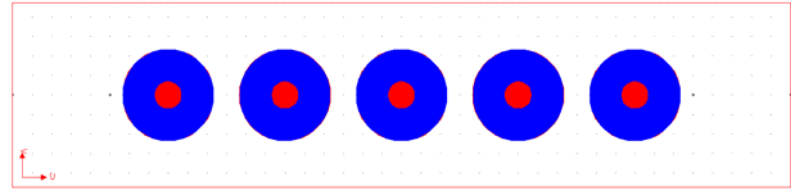

Electrostatic Analysis

Maxwell Capacitance Matrix (Distributed F/m)	
Conductor	
Conductor	1.3164E-010

Method 2: Lumped, Frequency-Dependent Model using the Maxwell Transient Solver

- Considerations:
 - Voltage transients do not include high frequency harmonic components due to insufficient number of cells used.
 - Circuit is manually created.

Simulation

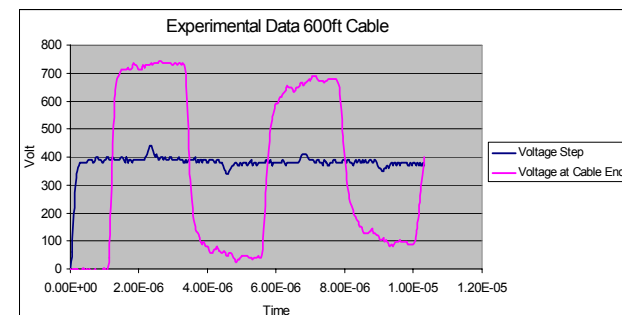
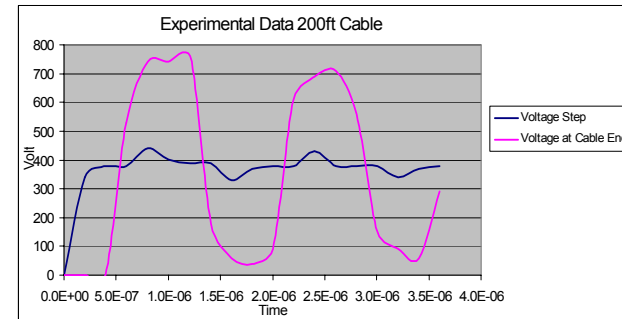
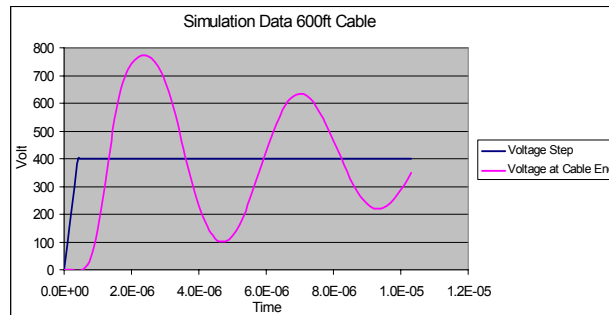
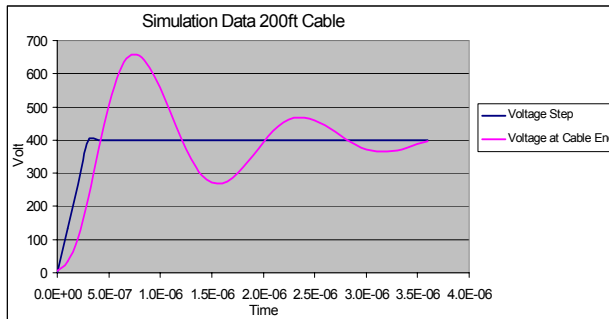

Measured

Method 3: Frequency-Dependent, Model Using Q3D and Simplorer – Preferred

- Single phase conductor model for shielded coaxial cable.
- FEA results validated with analytical calculations for R,L,C,G.
- Frequency-dependent netlist is derived using Q3D (2D Extractor).
- Netlist imported into Simplorer for system simulation.

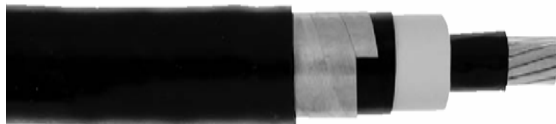
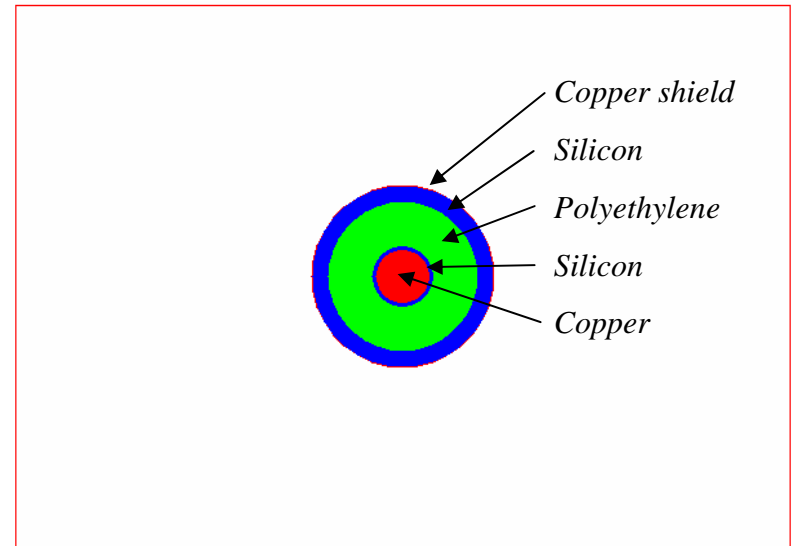

General Cable Uniblend®

EPR/Copper Tape Shield/PVC, Medium-Voltage Power, Shielded 15kV, UL Type MV-105, #2AWG

Analytical Calculations for Coaxial Cable

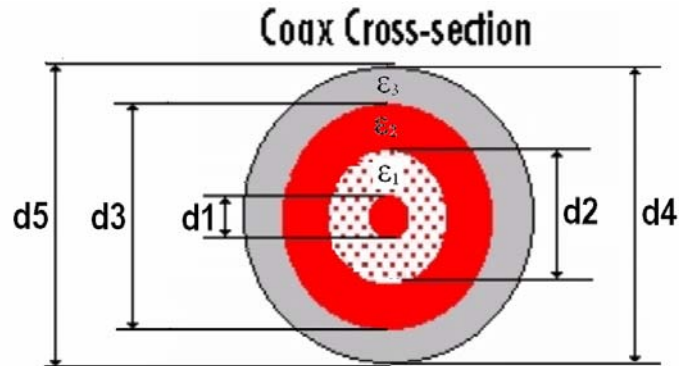

Outer diameter of conductor (d1) = 6.858 mm

Outer diameter material ε₁ (d2) = 7.874 mm

Outer diameter material ε₂ (d3) = 19.177 mm

Inner diameter shield (d4) = 25.396 mm

Outer diameter shield (d5) = 25.65 mm

$$R_{DC} = \frac{L}{\sigma A} = \frac{1}{5.8 * 10^7 * \pi (r_5^2 - r_4^2)} + \frac{1}{5.8 * 10^7 * \pi r_1^2} = \frac{1}{5.8 * 10^7 * \pi (0.012825^2 - 0.012698^2)} + \frac{1}{5.8 * 10^7 * \pi (0.0036939^2)} = 0.0021599 \text{ } [\Omega/\text{m}]$$

$$L = \frac{\mu_0}{2\pi} \ln \frac{d4}{d1} = 2 * 10^{-7} \ln \left(\frac{25.396}{6.858} \right) = 2.62 * 10^{-7} \text{ } [\text{H}/\text{m}]$$

$$C = \frac{2\pi\epsilon_0}{\frac{1}{\epsilon_{r1}} \ln \left(\frac{d2}{d1} \right) + \frac{1}{\epsilon_{r2}} \ln \left(\frac{d3}{d2} \right) + \frac{1}{\epsilon_{r3}} \ln \left(\frac{d4}{d3} \right)} = \frac{2\pi * 2.25 * 8.85 * 10^{-12}}{\frac{1}{11.9} \ln \left(\frac{7.874}{6.858} \right) + \frac{1}{2.25} \ln \left(\frac{19.177}{7.874} \right) + \frac{1}{11.9} \ln \left(\frac{25.396}{19.177} \right)} = 1.29 * 10^{-10} \text{ } [\text{F}/\text{m}]$$

FEA Calculations for Coaxial Cable

- Q3D and Maxwell 2D give identical results for R,L,C.
- Q3D also calculates R,L vs. frequency.
- Q3D exports frequency dependent R,L,G,C netlist.

Frequency independent results for R,L,C,G			
	Analytical	Q3D	Maxwell 2D
Capacitance (F/m)	$1.29 \cdot 10^{-10}$	$1.2914 \cdot 10^{-10}$	$1.2915 \cdot 10^{-10}$
Inductance 1MHz (H/m)	$2.62 \cdot 10^{-7}$	$2.618 \cdot 10^{-7}$	$2.618 \cdot 10^{-7}$
Resistance 1MHz (Ω /m)	--	0.015369	0.015391
Conductance (mhos/m)	--	$1.5565 \cdot 10^{-7}$	--

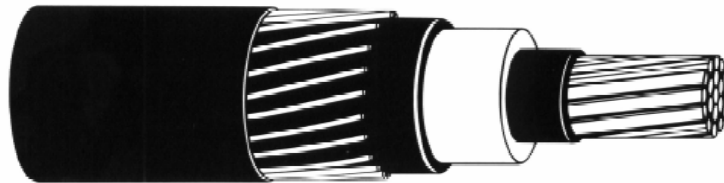

FEA Calculations for Coaxial Cable

- Frequency dependent results for R,L

Q3D

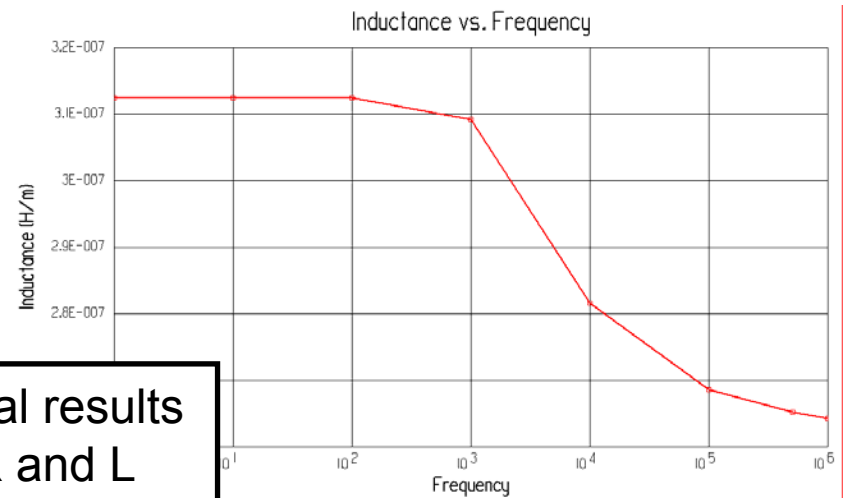
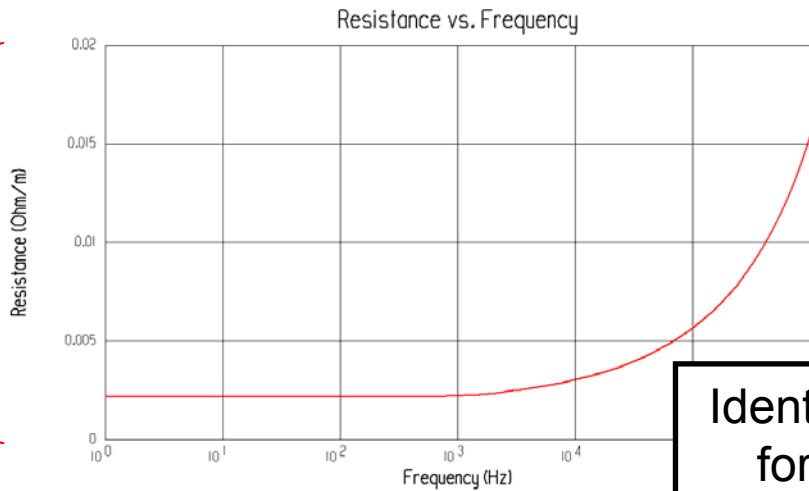

Identical results
for R and L
vs.
frequency

Maxwell 2D

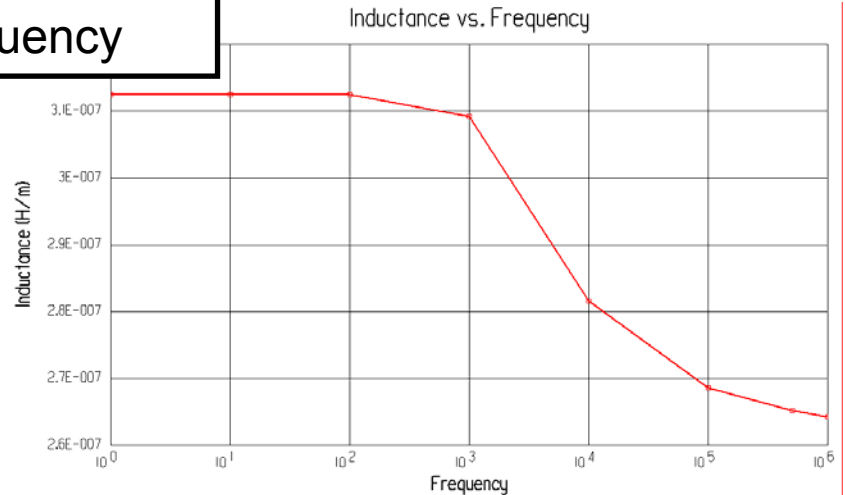
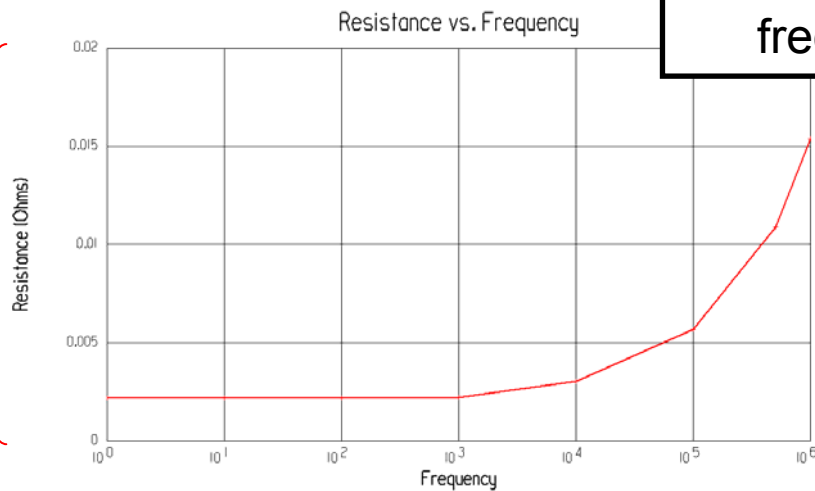

Q3D – 2D Extractor Overview

The screenshot displays the Ansoft 2D Extractor software interface. The main window is titled "Ansoft 2D Extractor 'gencab6_to_mark_lowfreq'". The top menu bar includes "Variables", "Model", "Solutions", "Convergence", and "Profile". The left sidebar contains a list of "Executive Commands" with checkmarks and dropdown arrows. The "Setup Solution Parameters" command is highlighted with a red circle, and its sub-menu is open, showing "Capacitance...", "Inductance...", "Impedance..." (highlighted with a red circle), and "Admittance...". Below this, "Variables..." and "Select Matrix Entries..." are also highlighted with red circles. The main area shows the "Impedance Solve Setup" dialog box. The "Solve for:" section has checkboxes for "Fields" (checked), "Parameters" (checked), and "Sweep" (unchecked). A red circle highlights the "Sweep" checkbox, with a red arrow pointing to the text "Include Frequency Sweep". Other settings in the dialog include "Starting Mesh" (Current), "Solver Residual" (1e-005), "Solver Choice" (Auto), "Frequency" (1 Hz), "Maximum Sweep Iterations" (60), and "Adaptive Analysis" (checked). The bottom status bar reads "Ansoft 2D Extractor VERSION 7.1.510 Copyright 1984-2006 Ansoft Corporation".

Q3D – 2D Extractor Export

- Exporting Netlist from Q3D

Format: Simplorer
Choose number of lumped cells
Specify length in meters
Compute Cells . . .

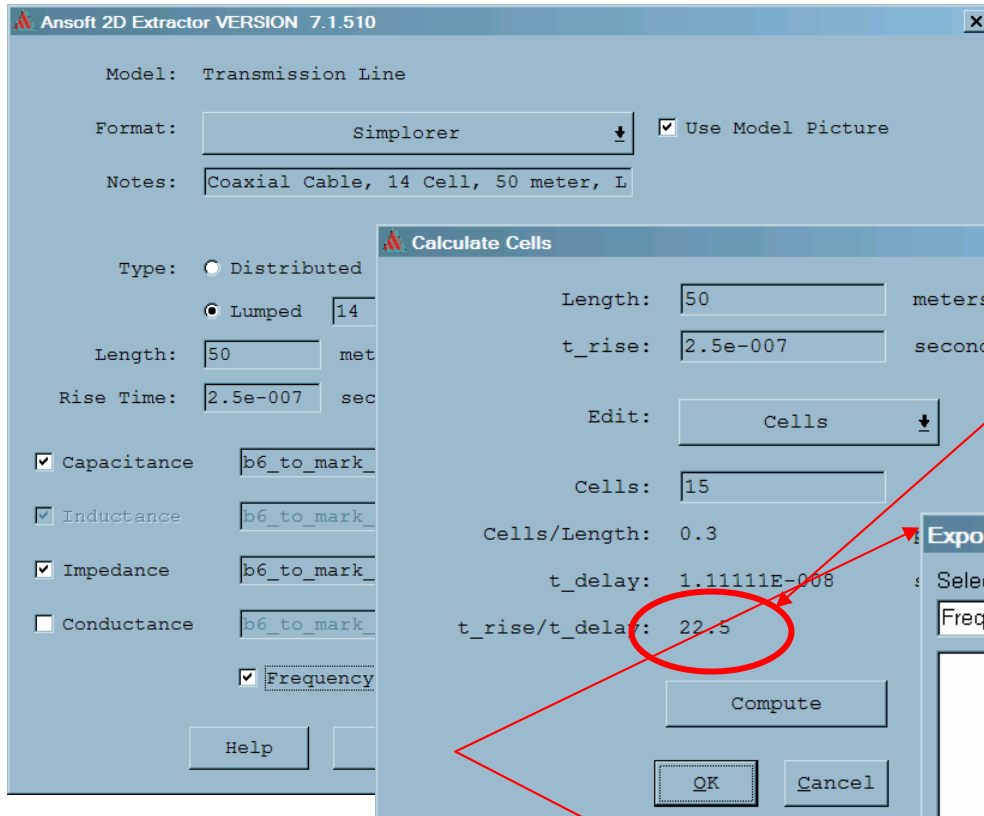

$t_{rise}/t_{delay} > 20$

For accurate representation of traveling waves.

Create Equivalent . . .
to export model

Check Frequency Dependent

Transmission Line Model with 1-cell

- Frequency independent circuit

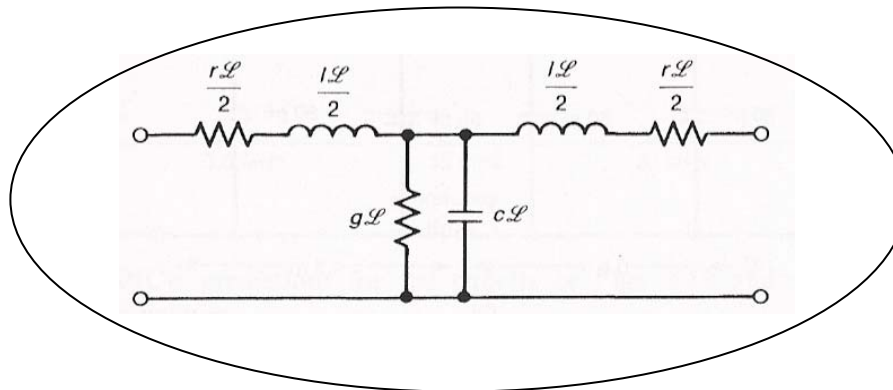
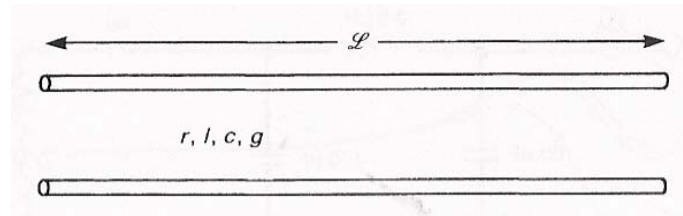

Lumped T-model

Transmission Line Model with 1-cell

Exported Netlist

```

* BEGIN ANSOFT HEADER
* node 1 Conductor_A
* node 2 Conductor_B
* node 3 Ground_Bias
* Length: 1 meters
* T_Rise: 1E-009 seconds
* Model: Lumped Lossy Transmission Line
* Type: RLGC
* Cells: 1
* Project: gencab4
* Cap: c:/files/projects/q3d/gencab4.pjt/es.pjt/es.cap
* Imp: c:/files/projects/q3d/gencab4.pjt/ed.pjt/ed.prz
* Cnd: c:/files/projects/q3d/gencab4.pjt/ac.pjt/ac.adm
* END ANSOFT HEADER
.SUBCKT gencab4 1 2 3
Xgencab4_la 1 4 gencab4_half
Xshnt_001 4 3 gencab4_shnt
Xgencab4_lb 4 2 gencab4_half
.ENDS gencab4
.SUBCKT gencab4_half 1 2
* Self for Conductor
V001_001 5 2 DC 0
R001_001 1 7 0.0159564
L001_001 7 8 1.31303E-007
C_000001 8 9 8 9 1.504E+007
C_000001 8 9 0.174232
G_000002 9 10 9 10 -103.989
C_000002 9 10 -8.62757E-006
G_000003 10 11 10 11 -1300.76
C_000003 10 11 -0.000233219
G_000004 11 12 11 12 -593.011
C_000004 11 12 -0.000204645
G_000005 12 13 12 13 -221833
C_000005 12 13 -0.118011
G_000006 13 14 13 14 -1082.71
C_000006 13 14 -0.000854983
G_000007 14 15 14 15 -1763.97
C_000007 14 15 -0.00266081
G_000008 15 16 15 16 -1630.55
C_000008 15 16 -0.00582644
G_000009 16 17 16 17 -2476.42
C_000009 16 17 -0.0280004
G_00000a 17 5 17 5 -3479.5
C_00000a 17 5 -0.182607
.ENDS gencab4_half
.SUBCKT gencab4_shnt 1 2
CO01 1 2 1.29142E-010
RG001 1 2 6.42475E+006
.ENDS gencab4_shnt

```

Lumped T-model

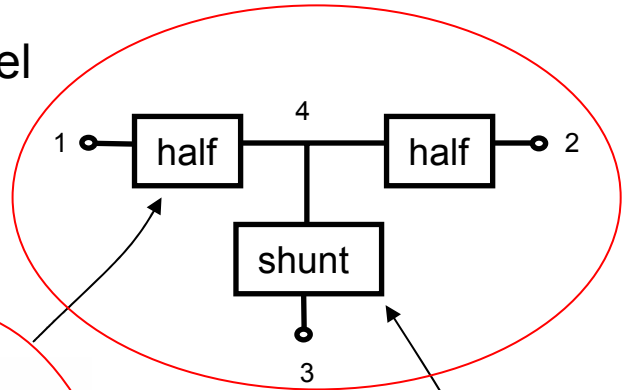

Frequency dependent elements

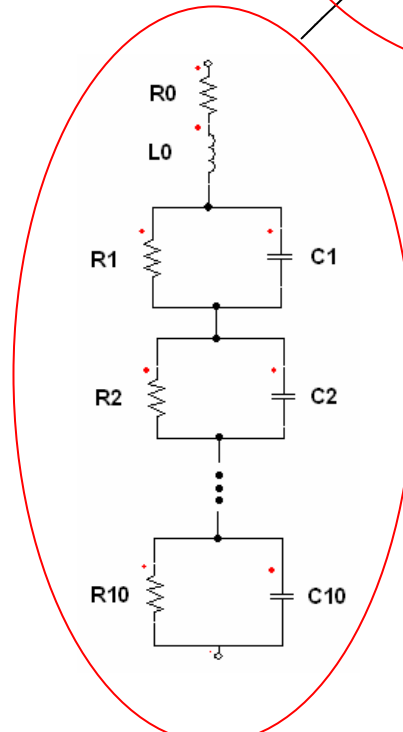

Frequency independent elements

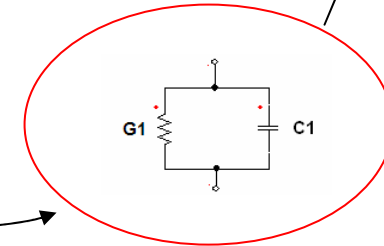

Q3D/Simplorer vs. Experimental Results

- 400V step input with risetime = 0.25usec.
- Lumped frequency-dependent model used with 50 cells.
- Over-voltage and resonant frequency vary with cable length.

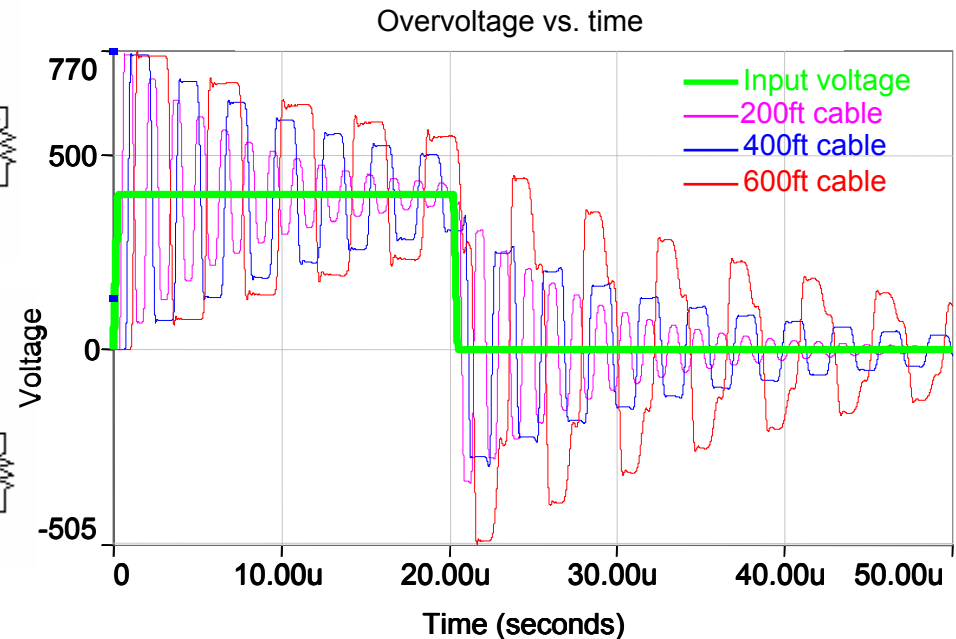
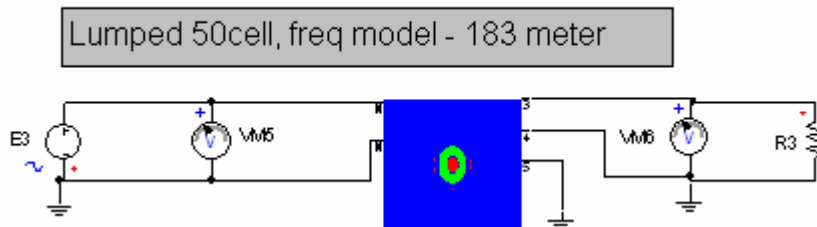
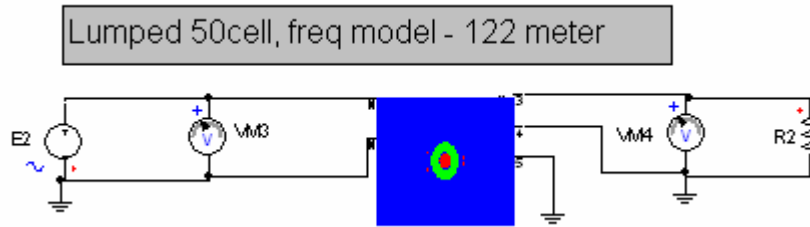
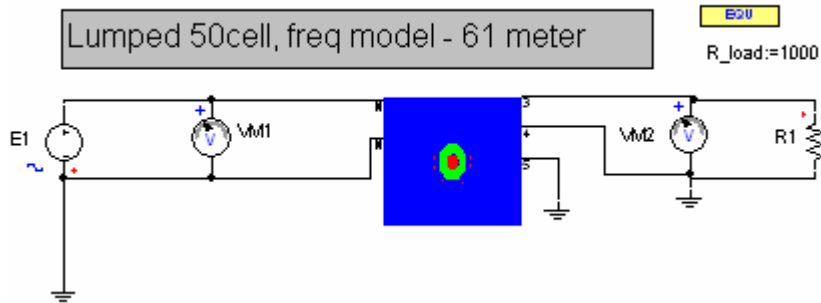

Q3D/Simplorer vs. Experimental Results

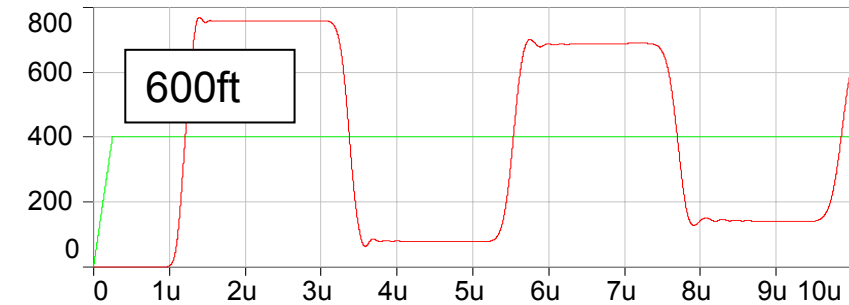
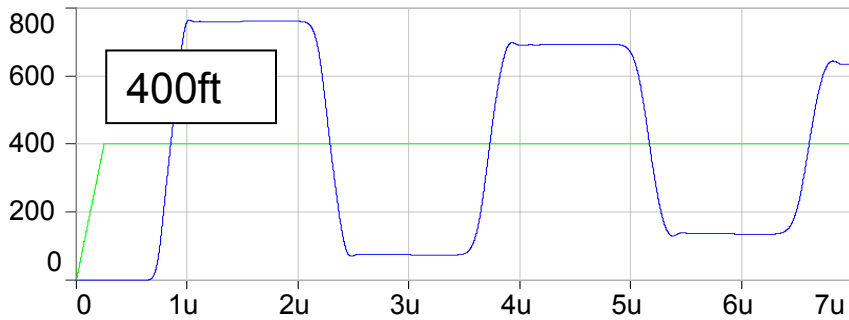
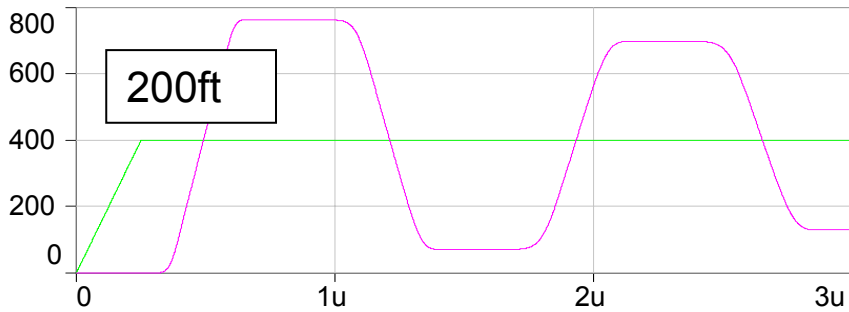

Simulation

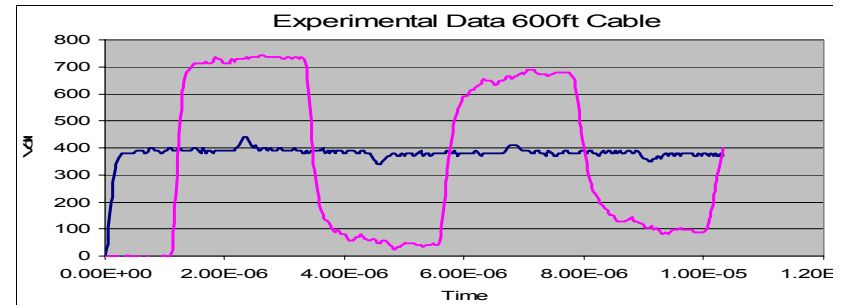
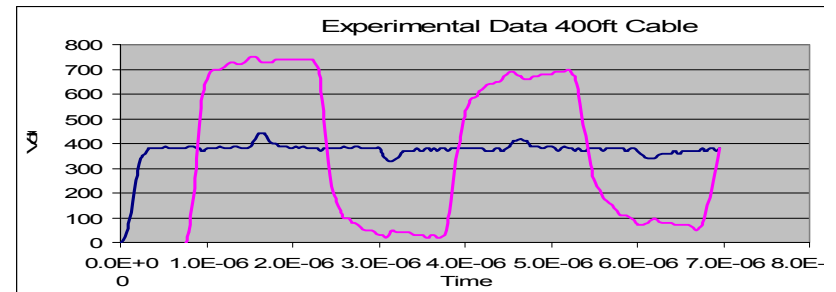
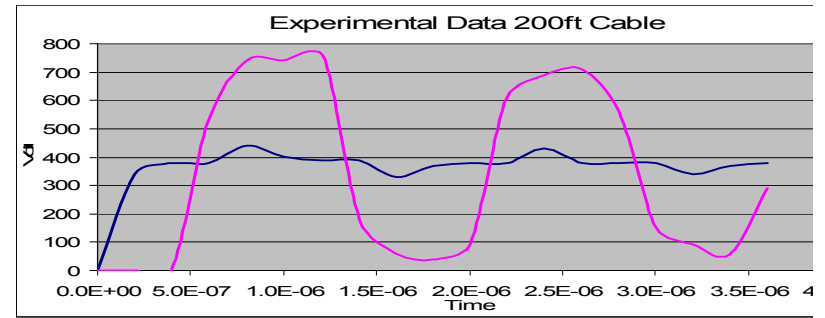

Experimental

Simplorer Transient Results

- Simulation of three cases for coaxial cable:
 - Linear cable model exported at 1Hz (blue).
 - Linear cable model exported at 1MHz (light blue).
 - Frequency Dependent model (red).

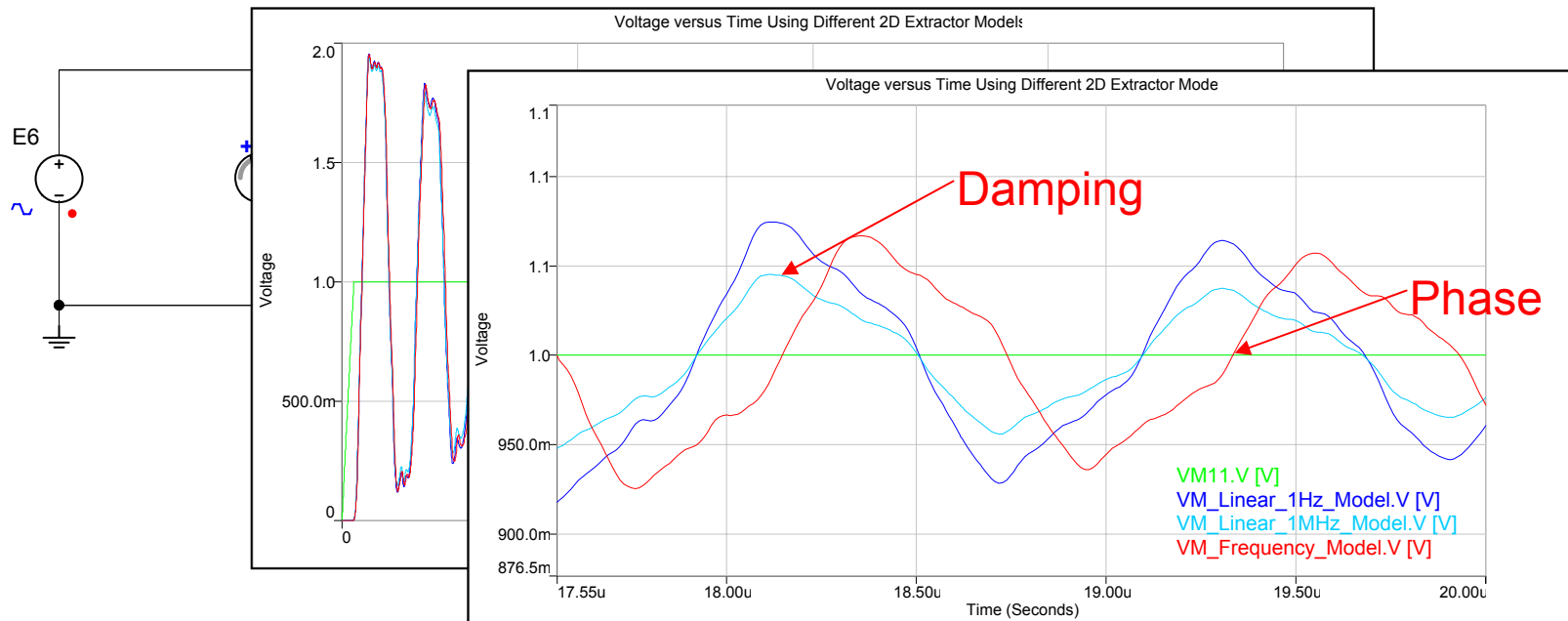

Simplorer Transient Results

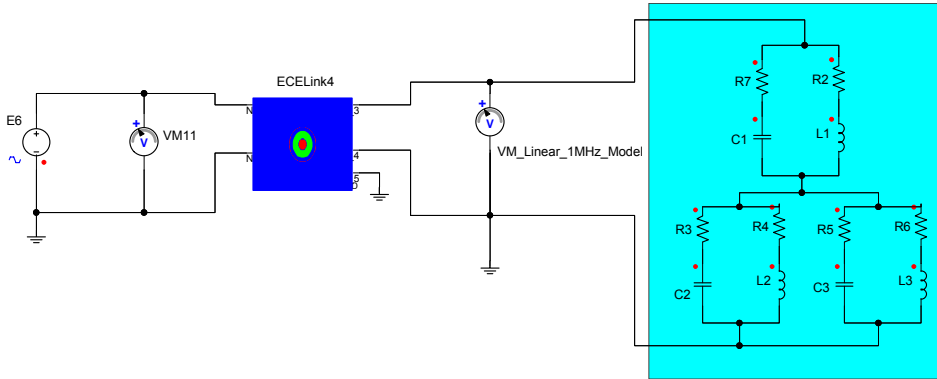

- Simulation of three cases for coaxial cable with load:
 - Linear cable model exported at 1Hz (blue).
 - Linear cable model exported at 1MHz (light blue).
 - Frequency Dependent model (red).
- Electrical motor model is a surge impedance equivalent model obtained from a set of measurements on a 100 hp motor.

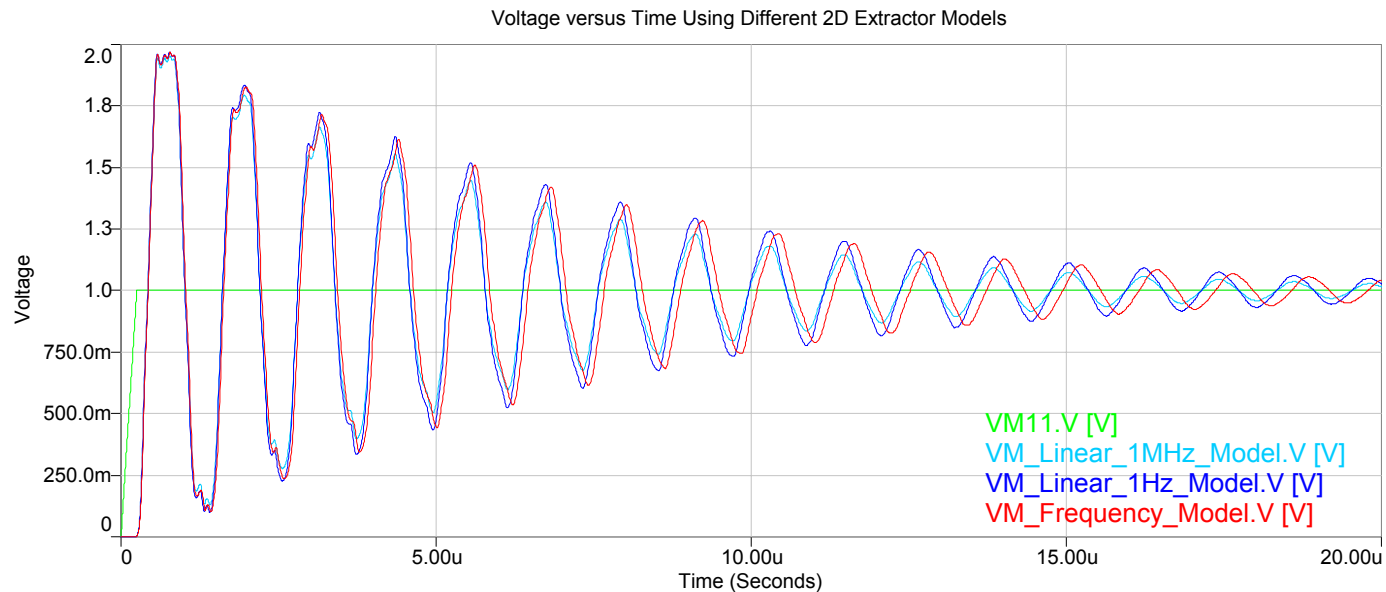

3Phase Coaxial Cable Simulation

3Phase cable cross-section

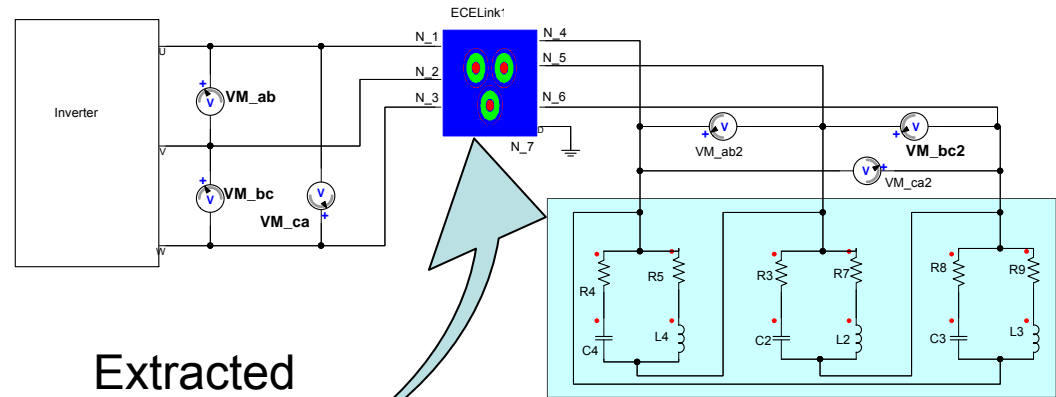
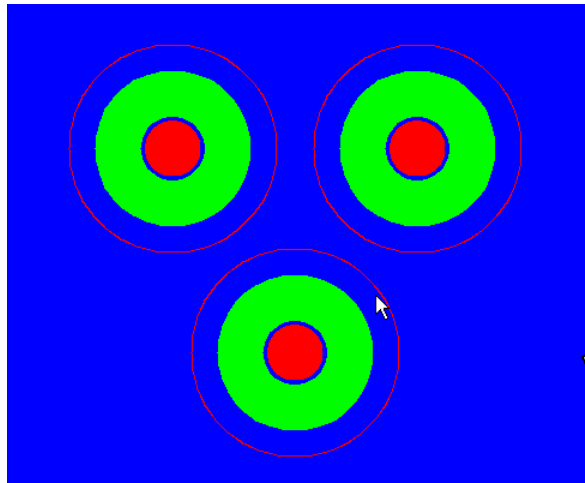

Extracted Model

3Phase simulation results with a 100hp motor surge impedance load.

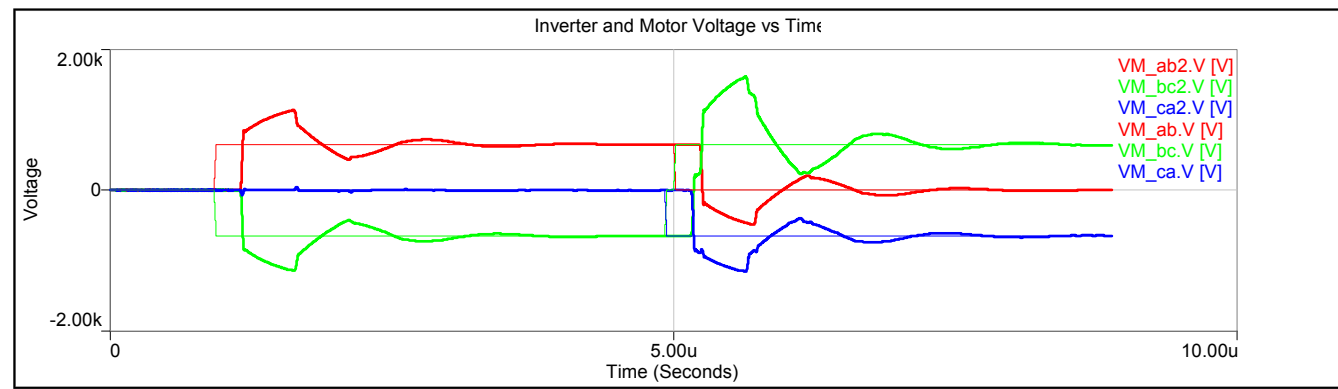

Summary

- **Q3D** and **Simplorer** can be used to easily simulate cable models in the time-domain.
- Three unique methods for creating system models have been presented:
 - Lumped, *frequency-independent*, hierarchical using Simplorer.
 - Lumped, *frequency-dependent* using Maxwell 2D transient with external circuit.
 - Lumped, *frequency-dependent* model exported from Q3D into Simplorer.
- Traveling waves, over-voltages, and resonant frequencies were shown in several examples.

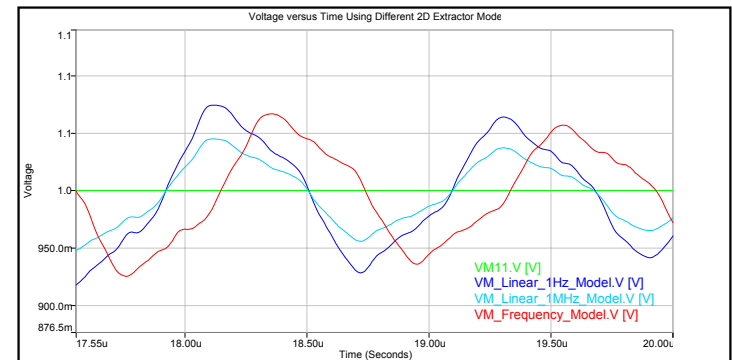
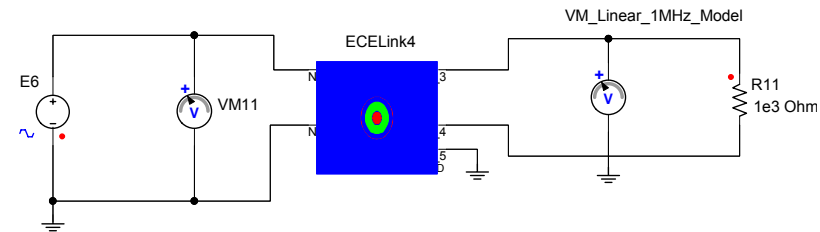

Other Considerations: Q3D/Simplorer Cable Studies

Lumped cell study with different number of cells:

- Frequency dependent 200ft lumped with 1 cell.
- Frequency dependent 200ft lumped with 10 cells.
- Frequency dependent 200ft lumped with 50 cells.

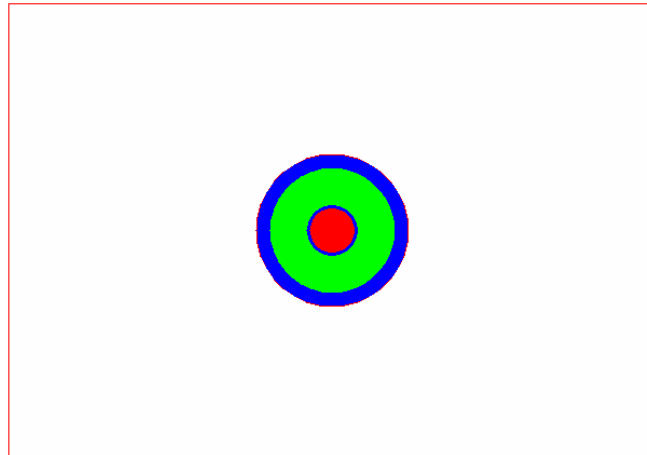

Other Considerations: Q3D/Simplorer Cable Studies

Lumped cell study

- Simulation of three cases for coaxial cable: number of cells = 1, 10, and 50.
- 200meter, lumped model, frequency dependent, 400V step with risetime = 0.25usec.
- Need 50 cells to get $t_{rise}/t_{delay} > 20$.

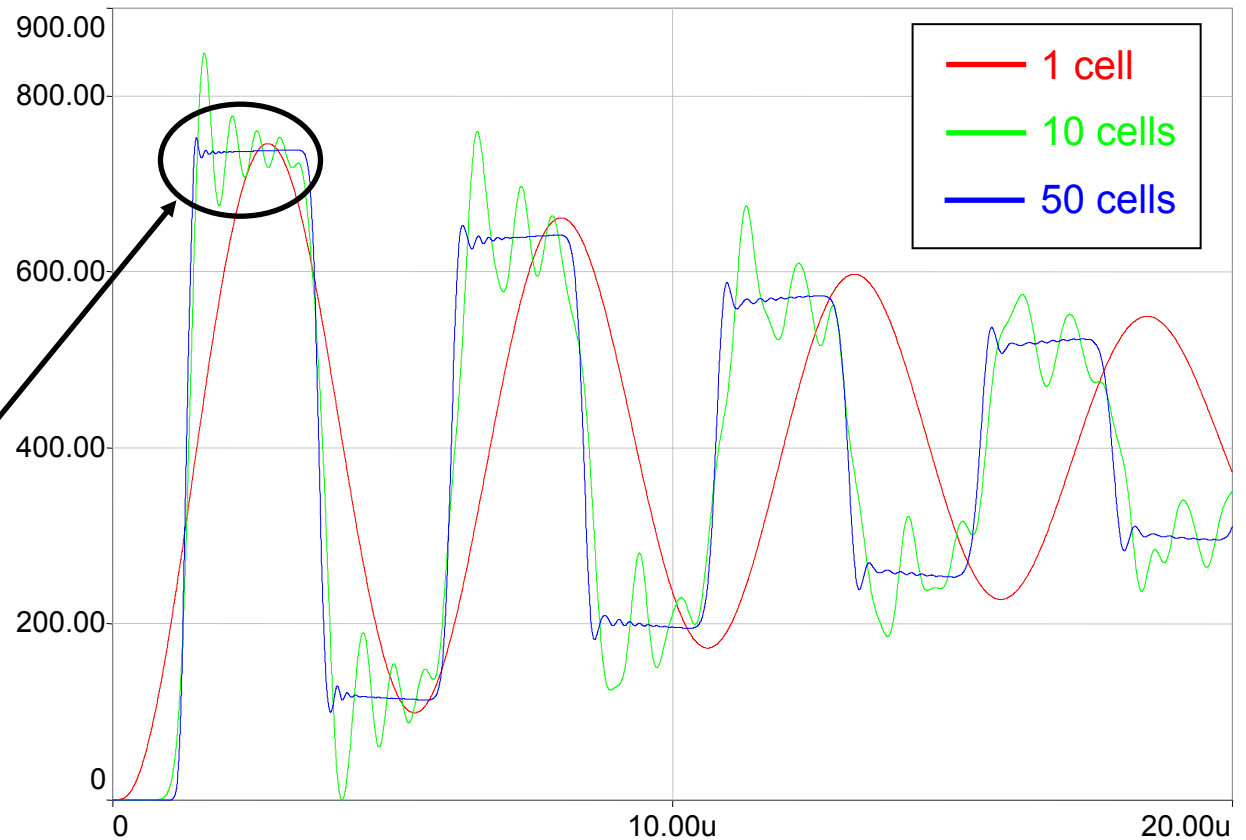
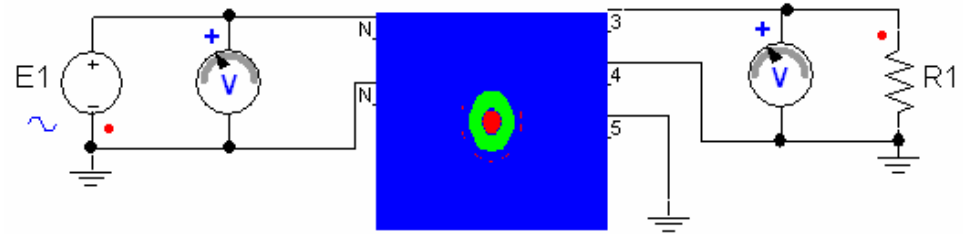

50 cell model needed to get accurate voltages

Other Considerations: Q3D/Simplorer Cable Studies

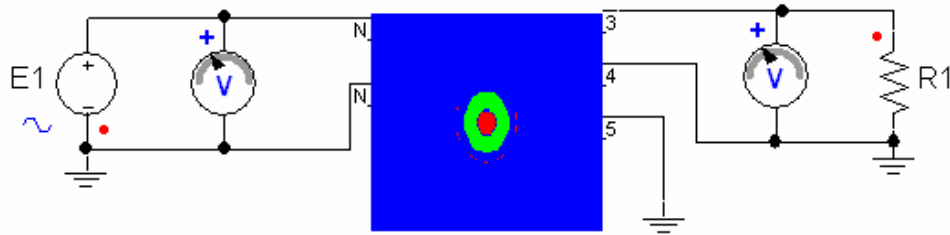

- Frequency Sweeps.
- Bode Plots can help aide in understanding the frequency response of a system.
 - Perform AC analysis in Simplorer.
 - Observe gain and phase vs. frequency.

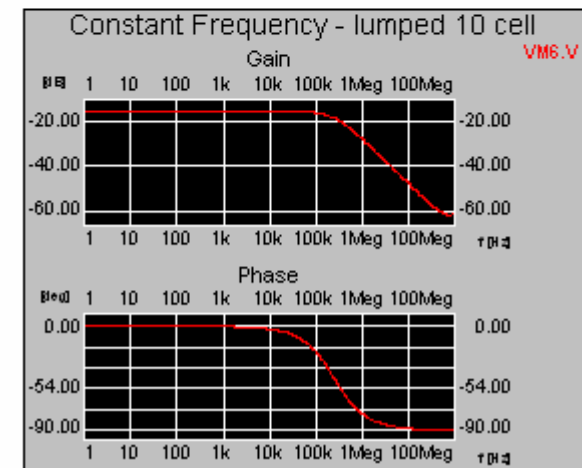
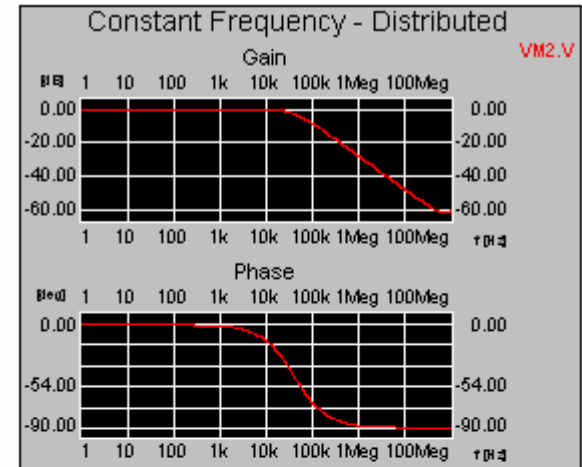

Conclusions

- The Q3D → Simplorer approach is the most robust and complete of the three methods presented.
- The Q3D (2D Extractor) models account for both frequency-dependency and traveling wave harmonics.
- The Q3D → Simplorer approach is seamless and efficient. It automatically provides models for time domain simulations for cable modeling.
- This approach can help engineers model traveling waves, over-voltages, and frequency-dependent phenomenon that occur in all types of interconnect structures.

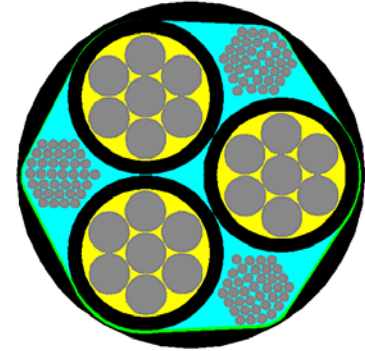

Future Work

- Simulate and validate other cable designs.
- Include various machine inverter models to study effects of frequency dependency, line lengths, rise times, cable designs, and load configurations using Q3D and Simplorer.
- Include frequency-dependent exported models from Q3D of bus structures, connectors, IPEMs, or other electrical devices.



References

References:

A.C. Baisden, D. Boroyevich, J.D. van Wyk, Center for Power Electronics Systems (CPES) Virginia Polytechnic Institute and State University, "Investigation of Conducted EMI in Converters with an RF Filter," IPEC, 2005.

Introduction to Electromagnetic Compatibility by Clayton R. Paul, 1992 by John Wiley & Sons

Electrical Transients in Power Systems by Allan Greenwood, 1971 by John Wiley & Sons

Power System Analysis by Charles A. Gross, 1986 by John Wiley & Sons