

Wideband Ground Bounce Noise Suppression and EMI Reduction in High-Speed Circuits

A Systematic Design to Suppress Wideband Ground Bounce Noise in High-Speed Circuits by Electromagnetic Band-Gap Enhanced Split Powers

Chien-Lin Wang, Guang-Hwa Shiue, Wei-Da Guo , and Ruey-Beei Wu , Senior Member, IEEE

This paper has been accepted for publication in the IEEE Transactions on Microwave Theory and Techniques, 2006.

Speaker : Guang-Hwa Shiue
(薛光華)

Ph.D., National Taiwan University
Assistant Professor, Jin-Wen Institute of Science and Technology

Outline

1. *Motivation*
2. *Introduction to EBG Structures*
3. *Design of Embedded EBG Structures*
4. *Wideband Noise Suppression*
5. *Summary and Conclusions*

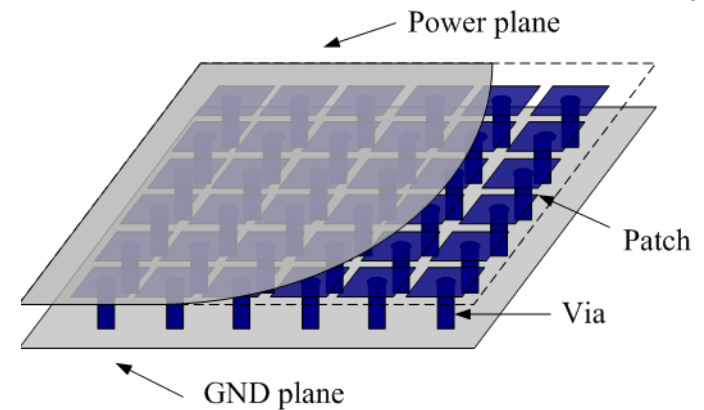
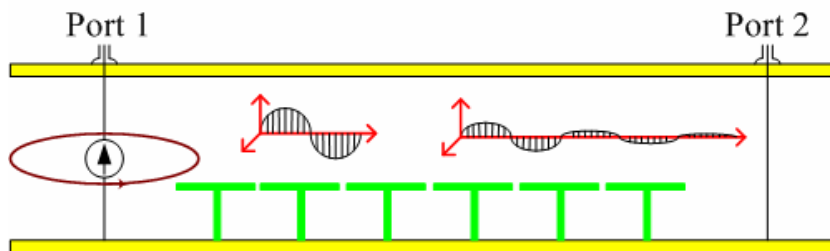

Outline

1. *Motivation*
2. *Introduction to EBG Structures*
3. *Design of Embedded EBG Structures*
4. *Wideband Noise Suppression*
5. *Summary and Conclusions*

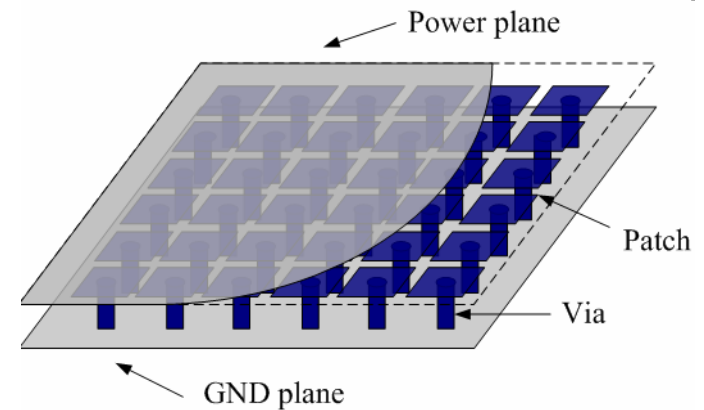
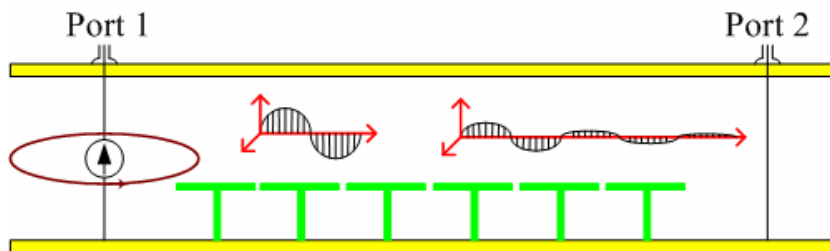

Signal through Planes

- The signal propagation down the vias in a multi-layer environment :
 - It will suffer from composite effects of reflected noise by via discontinuity
 - Ground bounce between power and ground planes

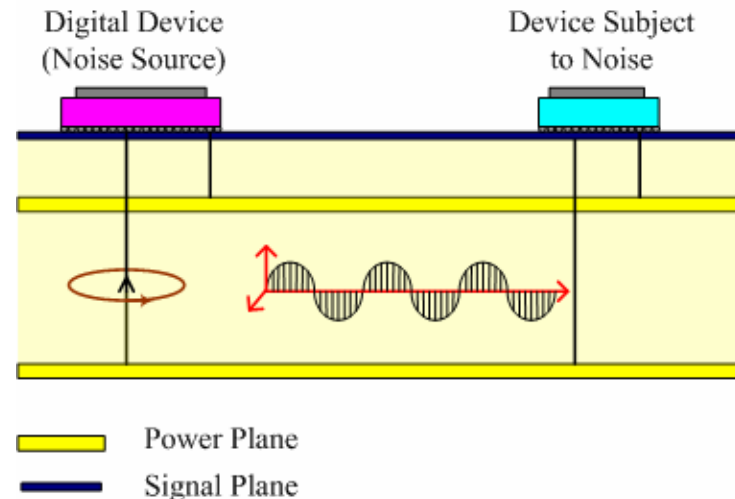
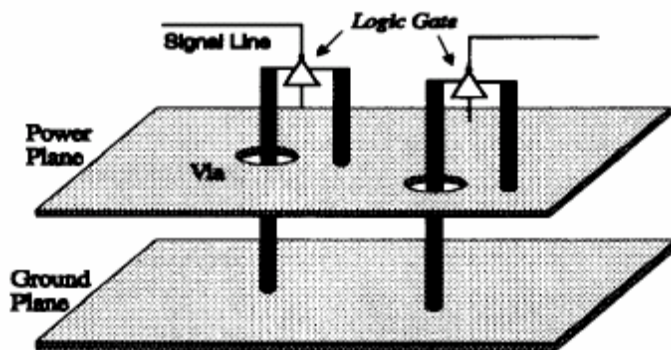

Signal crossing Slot

- Slots are common in PCB or MLC
 - Split image planes for multiple power distribution
 - Isolated islands in power/ground plane to isolate a noisy or sensitive circuit from other circuits

- Signal lines crossing slots to communicate with other chips cause SI concerns
 - Reflection due to the discontinuity in signal return path
 - Ground bounce between power and ground planes

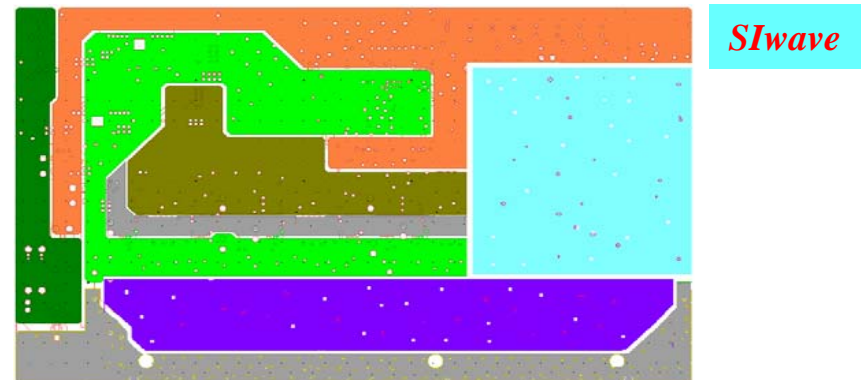
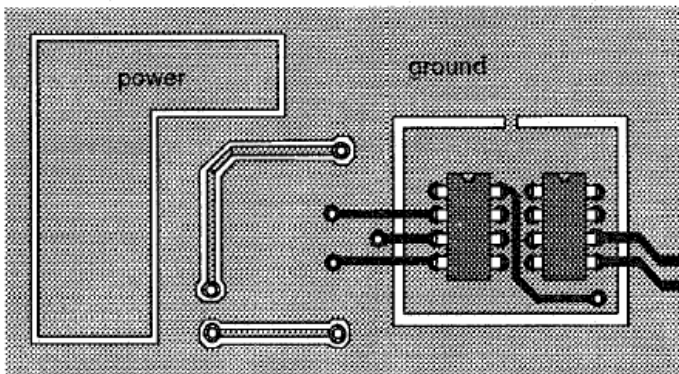

Two Excited Mechanisms of Ground Bounce

E Type :

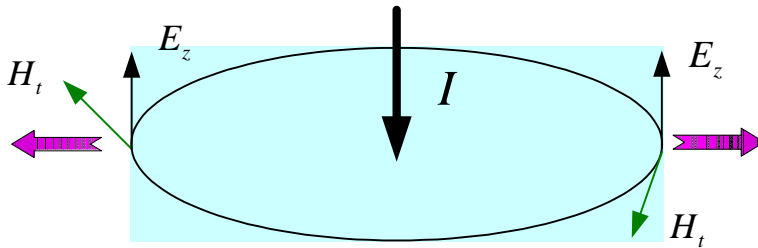
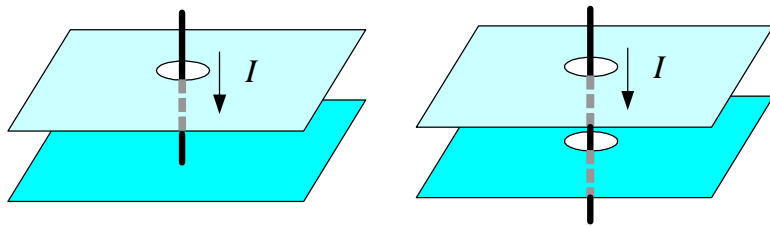

M Type :

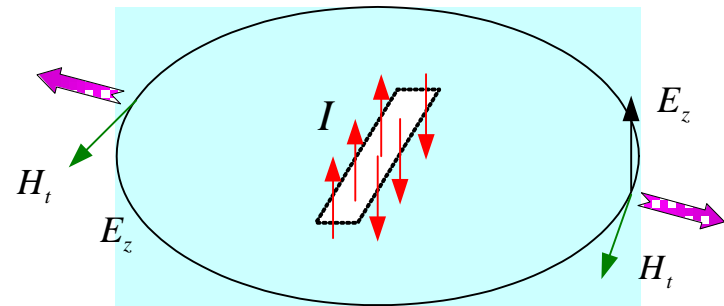
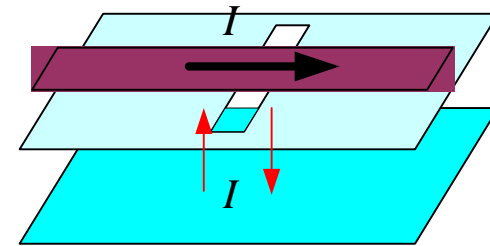

Ref. : S. M. Lin and R. B. Wu, "Composite effects of reflections and ground bounce for signal vias in multi-layer environment," in *Proc. IEEE Microwave Conf. APMC*, vol. 3, pp. 1127-1130, Dec. 2001.

C. T. Wu, G. H. Shiue, S. M. Lin, and R. B. Wu, "Composite effects of reflections and ground bounce for signal line through a split power plane," *IEEE Trans. Adv. Packaging*, Vol. 25, pp. 297-301, May 2002.

Motivation(2/2)

Resonance of Parallel Plate; G

$$f_{mn} = \frac{1}{2\sqrt{\mu\epsilon}} \sqrt{\left(\frac{m}{a}\right)^2 + \left(\frac{n}{b}\right)^2}$$

TEM mode(TM₁₀)

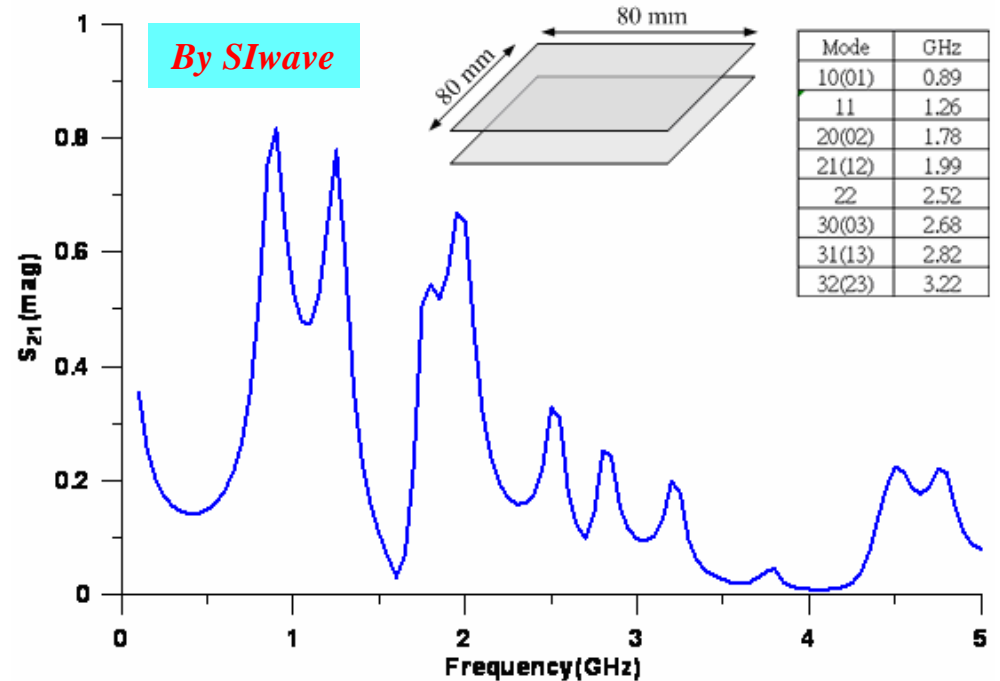
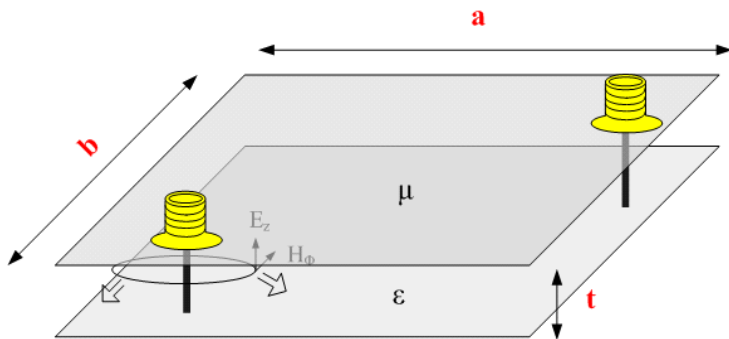

Motivation(2/2)

Ground Bounce Noise Reduction Technique: G

◆ Decoupling Capacitor

limited by the increasing impedance of ESL at high frequencies

◆ Dividing Power Plane

still resonating at certain frequencies and causing significant coupling noise

◆ Embedded Capacitor

expensive with the use of high dielectric material

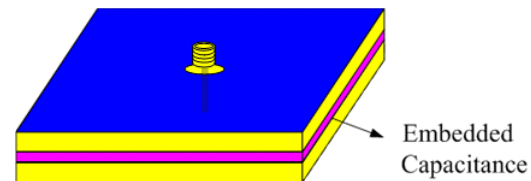
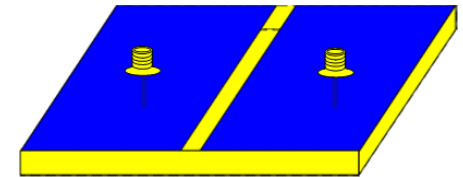
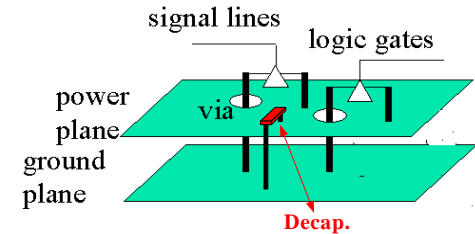

With the increasing clock frequencies of digital circuits, the ultra wideband noise suppression from DC to several GHz becomes a critical design consideration.

Outline

1. *Motivation*
2. *Introduction to EBG Structures*
3. *Design of Embedded EBG Structures*
4. *Wideband Noise Suppression*
5. *Summary and Conclusions*

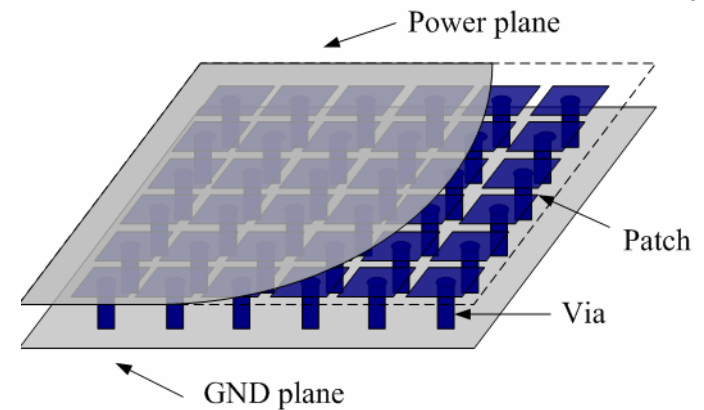
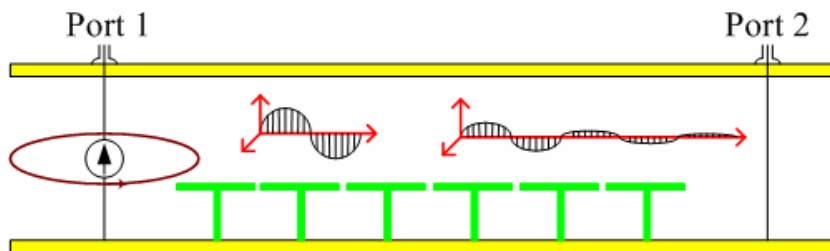

Noise Suppressing Mechanisms with EBG Structures(1/2)

Embedded EBG

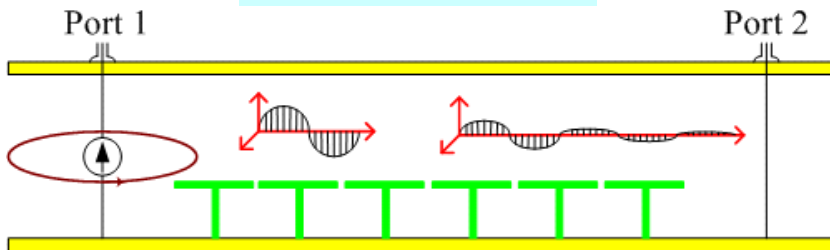

Low Periodic Coplanar PBG

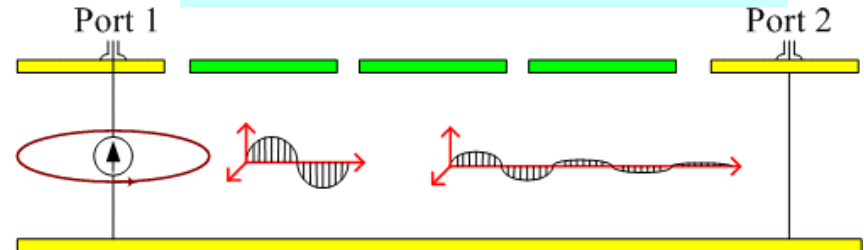

Electromagnetic Band-Gap (EBG)

- ◆ Suppressing SSN by blocking the propagation of the noise along the plane .
- ◆ Acting as band-stop filter and prevents EM energy from traveling the plane at specified frequency bandwidth .

Ref.

- [01] D. Sievenpiper, L. Zhang, R. F. Jimenez Broas, N. G. Alexopolous, and E. Eli Yablonovitch, "High-impedance electromagnetic surfaces with a forbidden frequency band," *IEEE Trans. Microwave Theory Tech.*, vol. 47, pp. 2059–2073, Nov. 1999.
- [02] T. Kamgaing and O. M. Ramahi, "A novel power plane with integrated simultaneous switching noise mitigation capability using high impedance surface," *IEEE Microwave Wireless Comp. Lett.*, vol. 13, pp. 21–23, Jan. 2003.
- [03] R. Coccioli, F.R. Yang, K.P. Ma, T. Itoh; "Aperture-coupled patch antenna on UC-PBG substrate," *IEEE Trans. Microwave Theory Tech.*, vol. 47, pp. 2123–2130, Nov. 1999.
- [04] T. L. Wu, Y. H. Lin, and S. T. Chen, "A novel power planes with low radiation and broadband suppression of ground bounce noise using photonic band-gap structures," *IEEE Microw. Compon. Lett.*, vol. 14, no. 7, pp. 337–339, Jul. 2004.

Noise Suppressing Mechanisms with EBG Structures(2/2)

Embedded EBG

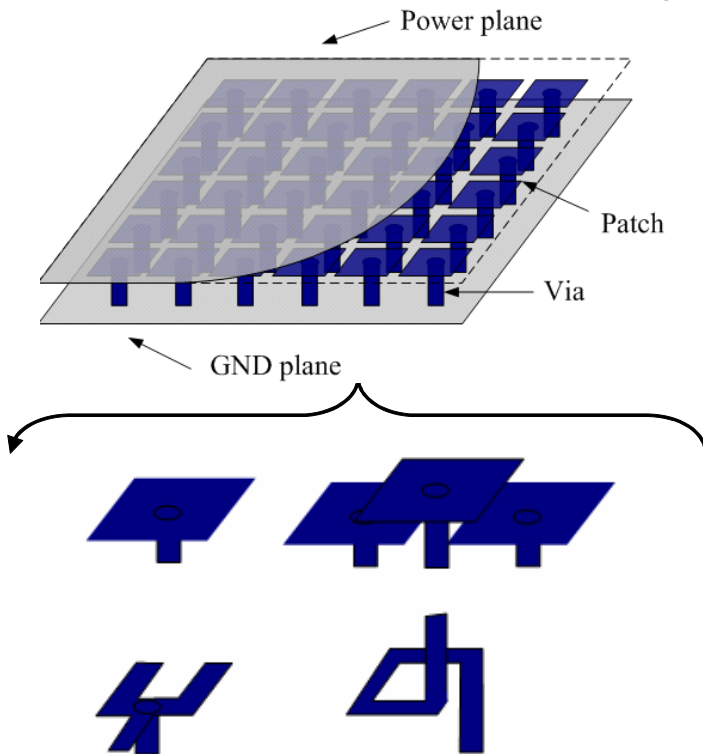

Low Periodic Coplanar PBG

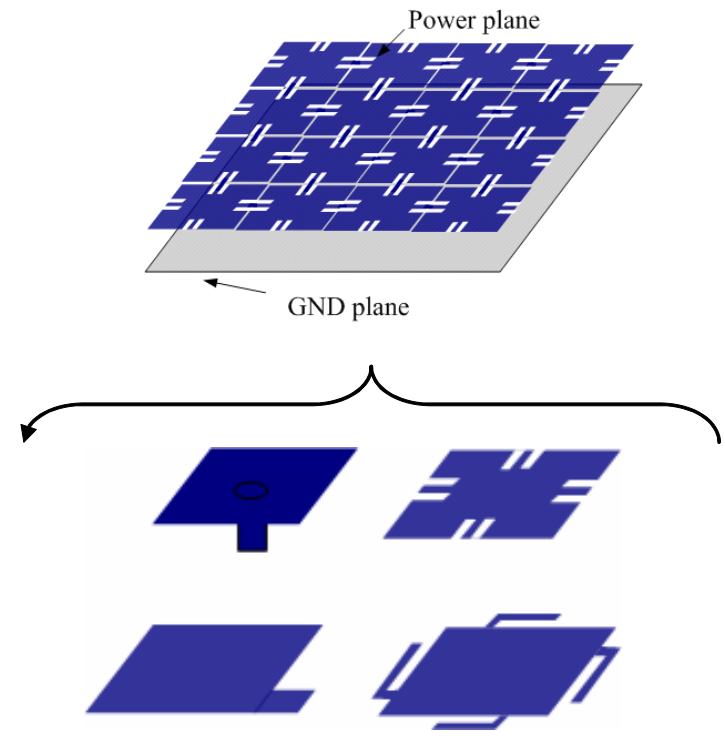

[Ref01] D. Sievenpiper, L. Zhang, R. F. Jimenez Broas, N. G. Alexopolous, and E. Eli Yablonovitch, "High-impedance electromagnetic surfaces with a forbidden frequency band," *IEEE Trans. Microwave Theory Tech.*, vol. 47, pp. 2059–2073, Nov. 1999.

[Ref02] R. Coccioli, F.R. Yang, K.P. Ma, T. Itoh; "Aperture-coupled patch antenna on UC-PBG substrate," *IEEE Trans. Microwave Theory Tech.*, vol. 47, pp. 2123–2130, Nov. 1999.

Equivalent Model of EBG Structures

Embedded EBG

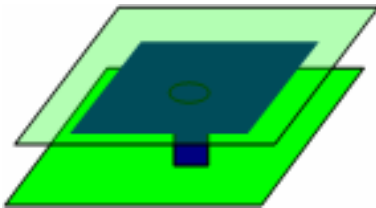

Low impedance Surface (LIS)

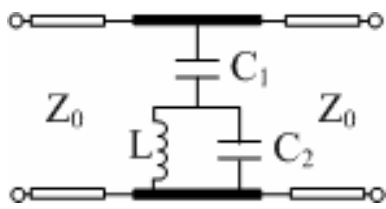

$$f_0 = \frac{1}{2\pi\sqrt{L(C_1 + C_2)}}$$

$$S_{21} = \frac{1}{1 + \frac{Z_0}{2Z_{in}}}$$

$$\frac{\omega_0 C_1 (1 - L_1 C_2 \omega_0^2)}{4c} Z_0 = \pm \Delta \omega$$

Low Periodic Coplanar PBG



High impedance Surface (HIS)

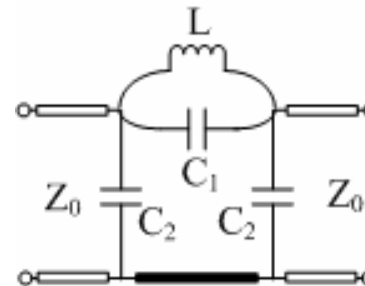

$$f_0 = \frac{1}{2\pi\sqrt{LC_1}}$$

$$\frac{\Delta \omega}{\omega_0} = \frac{Z_0}{\eta}$$

[Ref01] T. Kamgaing and O. M. Ramahi, "A novel power plane with integrated simultaneous switching noise mitigation capability using high impedance surface," *IEEE Microwave Wireless Comp. Lett.*, vol. 13, pp. 21-23, Jan. 2003.

[Ref02] D. Sievenpiper, L. Zhang, R. F. Jimenez Broas, N. G. Alexopolous, and E. Eli Yablonovitch, "High-impedance electromagnetic surfaces with a forbidden frequency band," *IEEE Trans. Microwave Theory Tech.*, vol. 47, pp. 2059-2073, Nov. 1999.

Band Gap Effect of Embedded EBG Structures

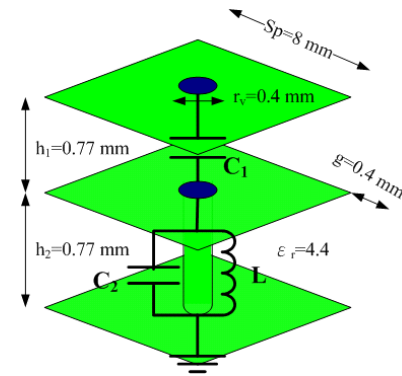
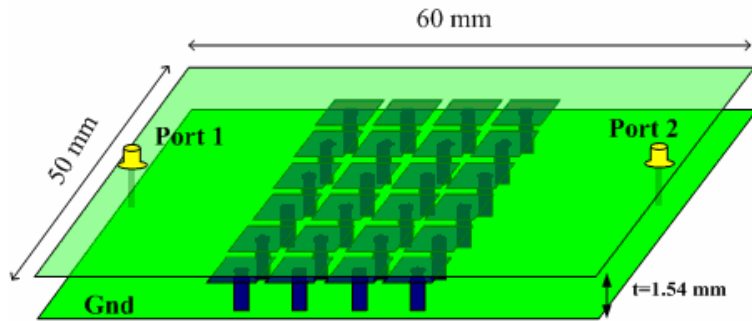

S-parameter simulation

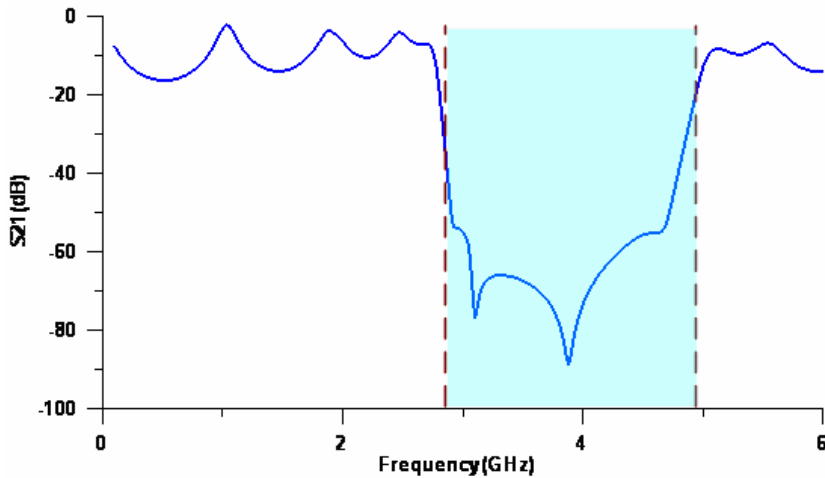

Dispersion diagram

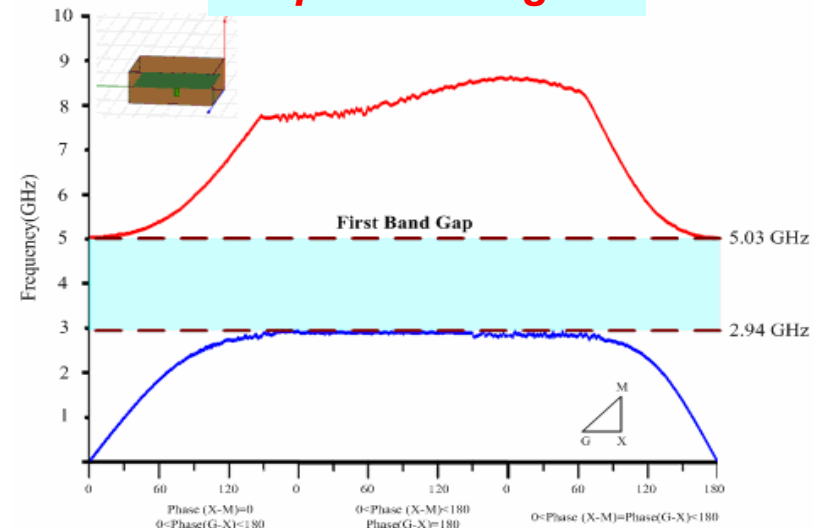

Outline

1. *Motivation*
2. *Introduction to EBG Structures*
3. *Design of Embedded EBG Structures*
4. *Wideband Noise Suppression*
5. *Summary and Conclusions*

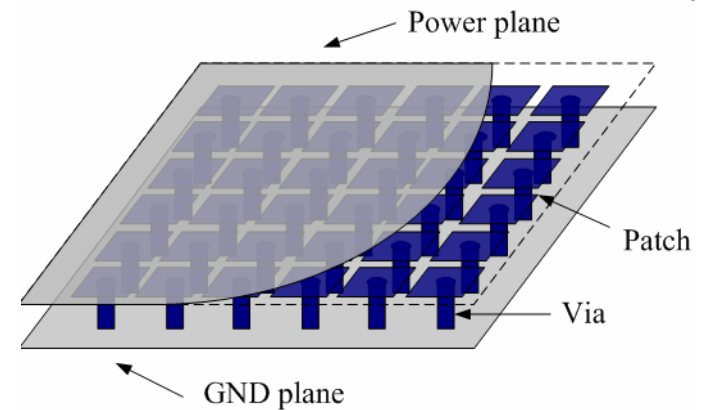
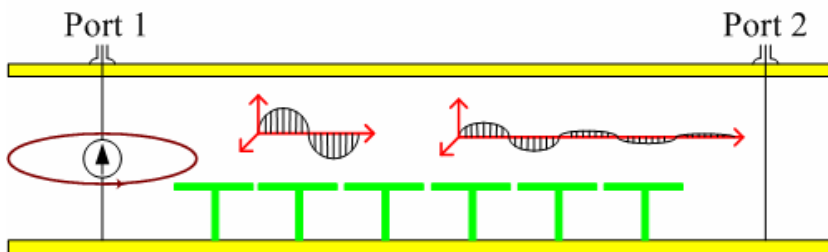

The Modified Formula of Induction Model

By full-wave simulator : f_c @GHz

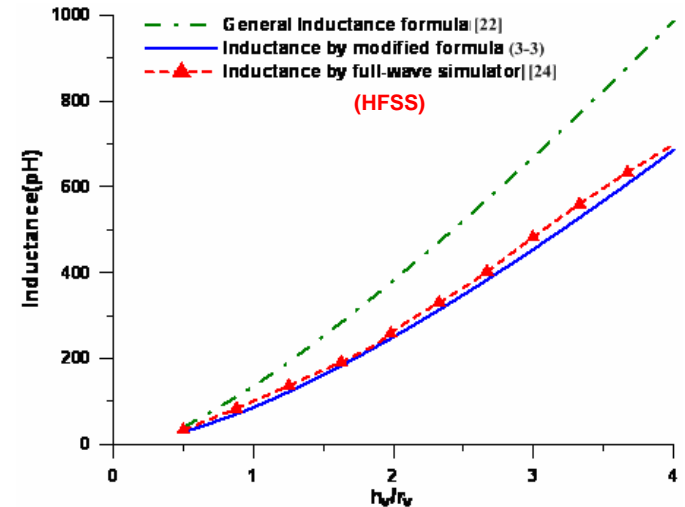
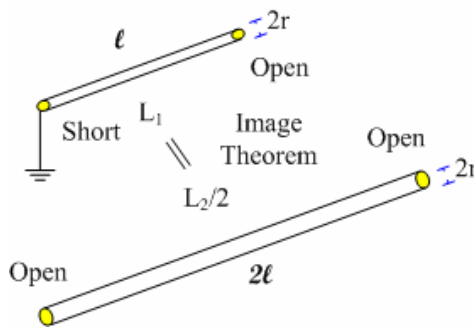
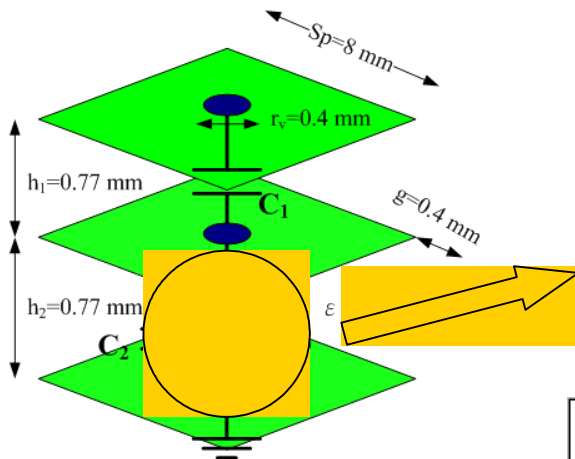

$$f_c = \frac{1}{2\pi\sqrt{L_1(C_1 + C_2)}}$$

$$C_1 = C_2 = \epsilon_r \epsilon_0 \frac{S_p^2}{h_v}$$

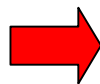

Reference	Design formula of inductance	Inductance(nH)	Center frequency(fc)	Appendix
ReBo [23]	$L = \mu \frac{h}{2} \left[0.026629 \left(\frac{h}{2r_v} \right) + 0.39073 \right]$	0.201 nH		$h/r > 4$
H.J. [22]	$L = \mu \frac{h_v}{2\pi} \left[\ln \left(\frac{2h_v}{r_v} \right) + 1 \right]$	0.362 nH		$h \gg r$
Paper [21]	$L = \mu \frac{h_v}{2\pi} \left[\ln \left(\frac{2h_v}{r_v} \right) - 0.1 \right]$	0.192 nH		$h=1.54\text{mm}$
Modified formula	$L = \mu \frac{h}{2\pi} \left[\ln \left(\frac{2h}{r} + \sqrt{1 + \left(\frac{2h}{r} \right)^2} \right) - \sqrt{1 + \left(\frac{r}{2h} \right)^2} + \frac{r}{2h} + \frac{1}{4} \right]$	0.235 nH		4 GHz

[21] S. Shahparnia and O. M. Ramahi, "Simple and accurate circuit models for high-impedance surfaces embedded in printed circuit boards," *IEEE Antenna Propagat. Symposium* 2004.

[22] H.W.Johnson, High-Speed Signal Propagation: Advanced Black Magic, Prentice Hall,2003 ch.5

Miniaturized EBG Design(1/4)

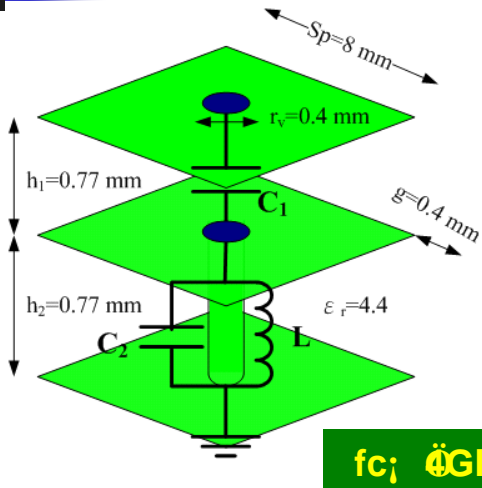

f_c 0 GHz

$$f_c = \frac{1}{2\pi\sqrt{L_1(C_1 + C_2)}}$$

$$C_1 = C_2 = \epsilon_r \epsilon_0 \frac{S_p^2}{h_v^2}$$

$$L = \mu_0 \frac{h_v}{2\pi} \left[\ln \left(\frac{2h_v}{r_v} + \sqrt{1 + \left(\frac{2h_v}{r_v} \right)^2} \right) - \sqrt{1 + \left(\frac{r_v}{2h_v} \right)^2} + \frac{r_v}{2h_v} + \frac{1}{4} \right]$$

Increasing C



[26][27]

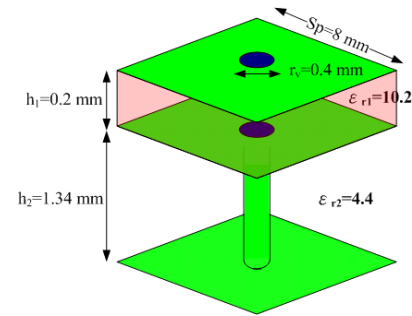

Increasing L

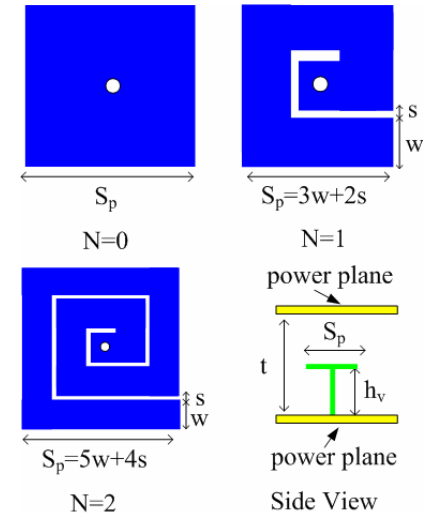

[26] J. Lee, H. Kim, and J. Kim, "High dielectric constant thin film EBG power/ground network for broadband suppression of SSN and radiation emissions," *IEEE Microwave Wireless Comp. Lett.*, vol. 15, pp. 505-507, Aug. 2005.

[27] S. Shahparnia and O M Ramahi, "Miniaturized electromagnetic bandgap structures for ultra-wide band switching noise mitigation in high-speed printed circuit boards and packages," *IEEE 13th Topical Meeting Elect. Perform. Electro. Packag.*, Oct. 2004, pp. 211-214.

Miniaturized EBG Design(2/4)

Spiral EBG Structures

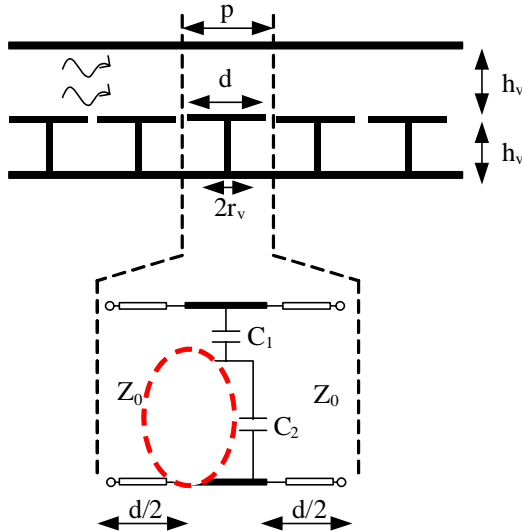
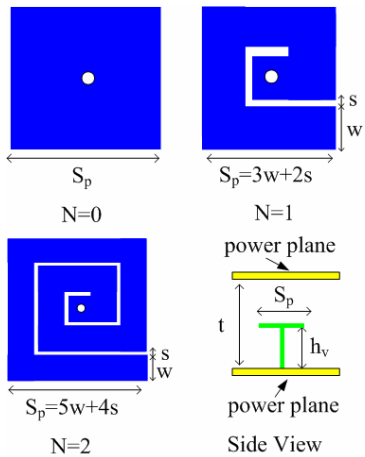

TYPE	Traditional	Spiral EBG
EBG Width (d)	9.5 mm	4.9 mm (N=1)
Frequency Range	2.5 ~ 4.3 GHz	2.8 ~ 4.1 GHz
FBW	53%	38%

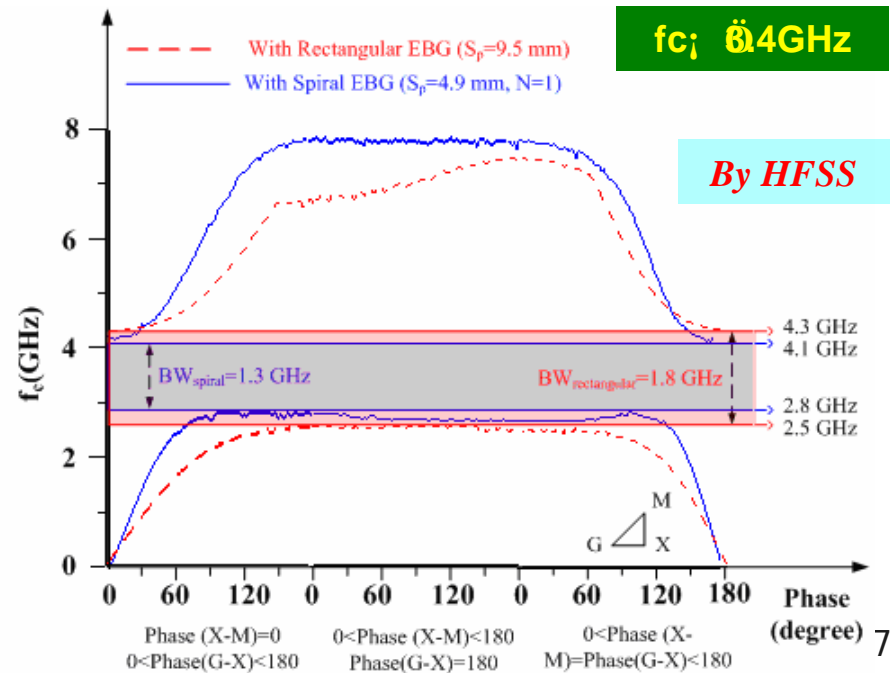

Miniaturized EBG Design(3/4)

$$f_c = \frac{1}{2\pi\sqrt{(L_{via} + L_{spiral})(C_{upper} + C_{lower})}}$$

L_{spiral} can be derived from the spiral EBG design diagram below

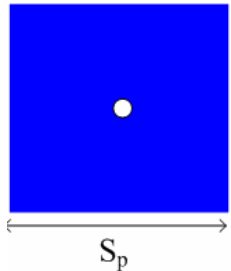
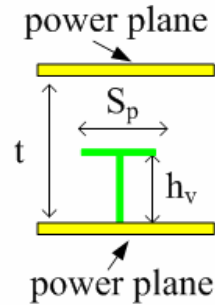
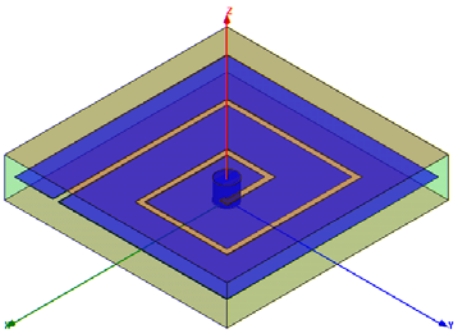

N=0

13 mm

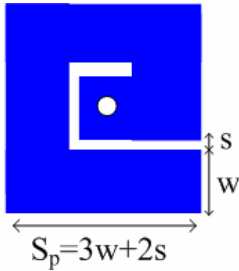

N=1

6.1 mm

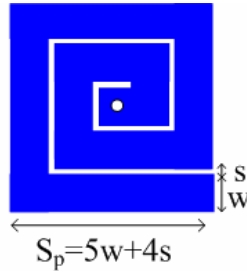

N=2

4 mm

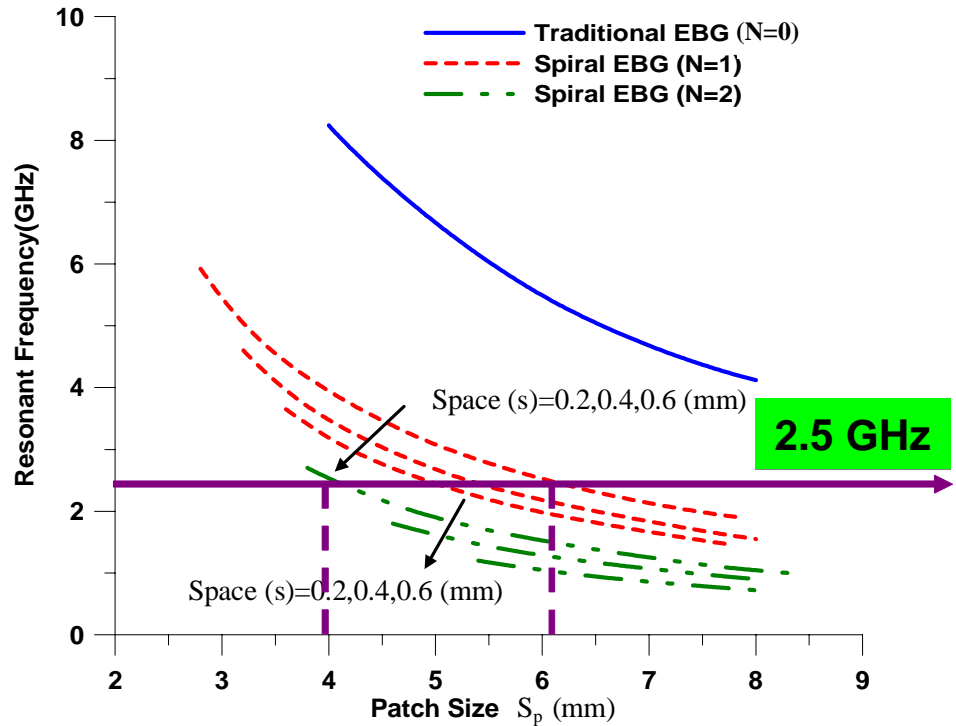

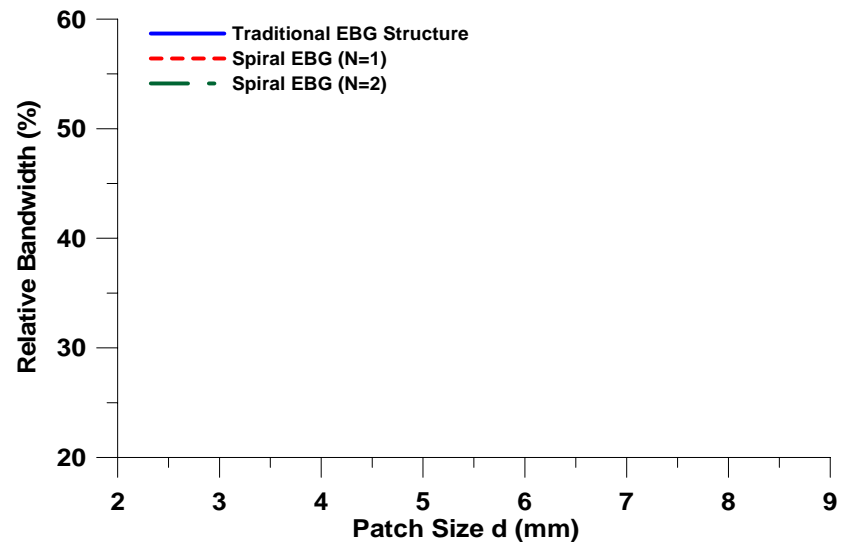
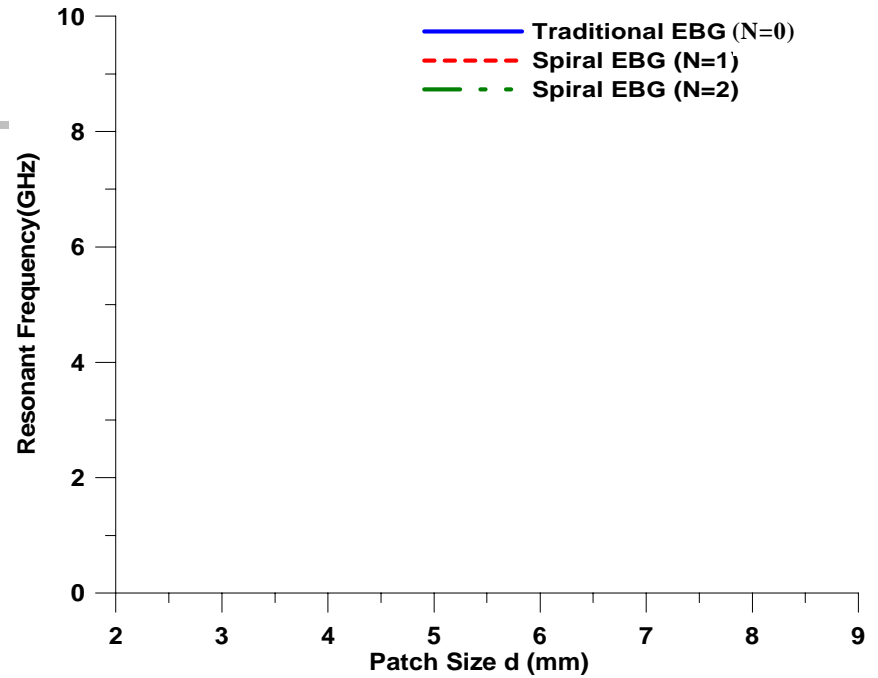
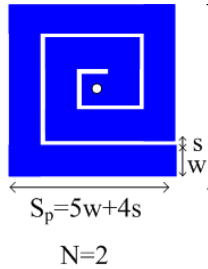
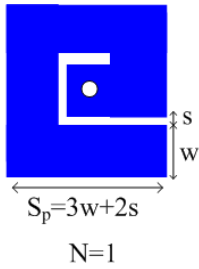
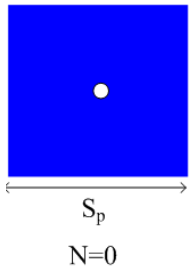
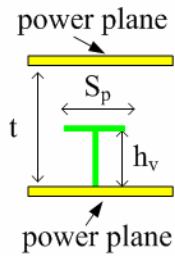
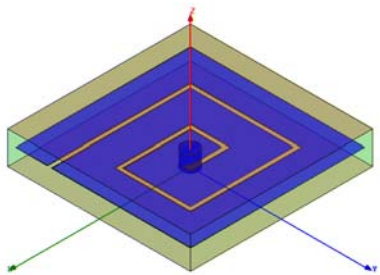

$h_1 = h_2 = 0.77$ mm

Miniaturized EBG Design(4/4)

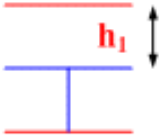
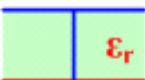

Parameter Analysis of EBG Design

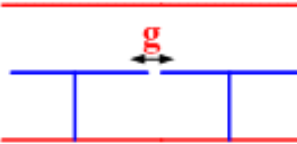
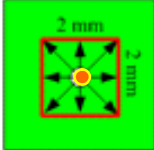
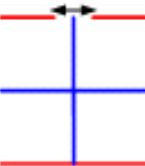
Category	Parameter	Dimension Change	Centre Freq.	Band-edge Effect	BW.
Model Included			negative correlation	Lower Side Band	positive correlation
			negative correlation	Upper Side Band	negative correlation
			negative correlation	Upper Side Band	negative correlation
			positive correlation	Upper Side Band	positive correlation
	Via Poition		negative correlation	Upper Side Band	negative correlation
Model Excluded	Via Type		No effect	No effect	No effect

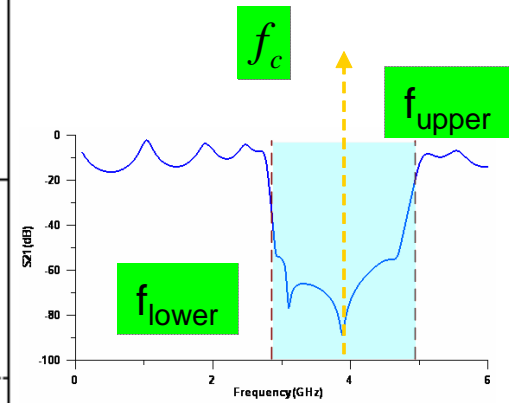
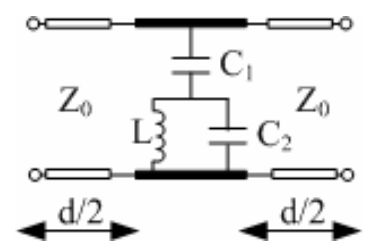
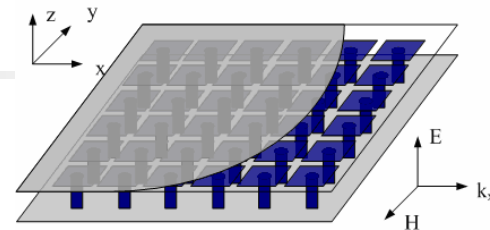

Effective Area Design

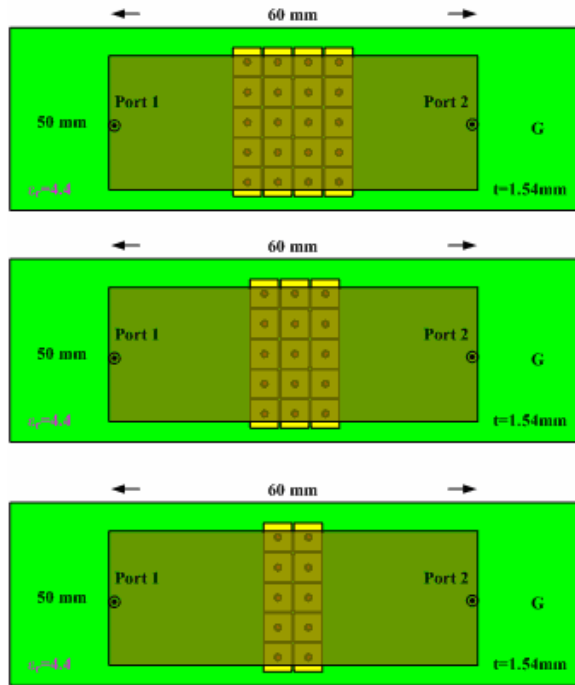

Number of Rows	1	2	3	4
Insertion Loss(S_{21})	5 dB	20 dB	25 dB	30 dB

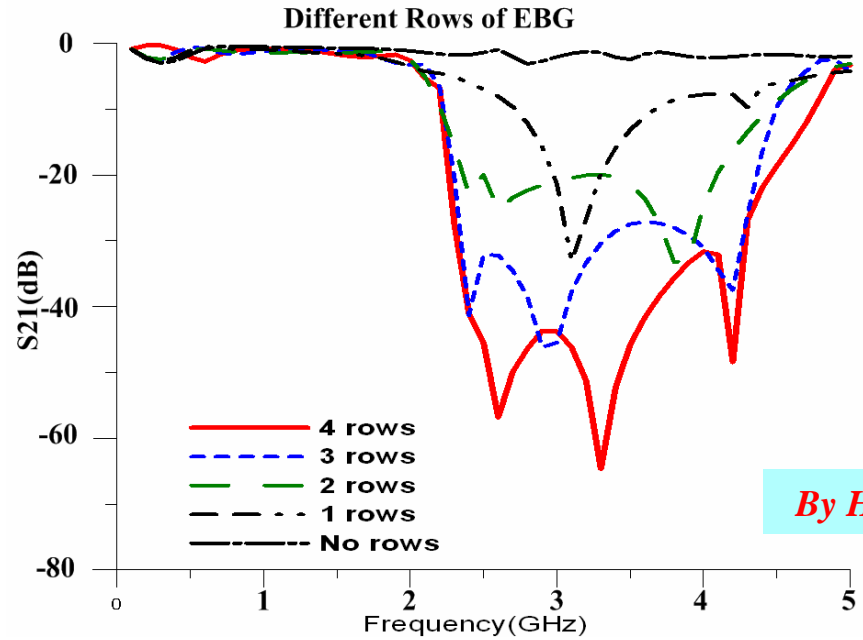

By HFSS

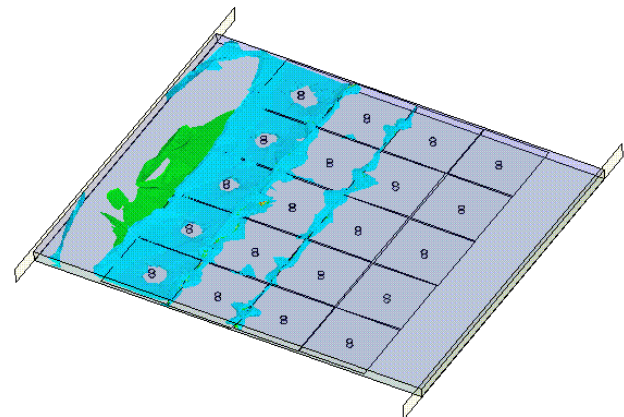

Outline

1. *Motivation*
2. *Introduction to EBG Structures*
3. *Design of Embedded EBG Structures*
4. *Wideband Noise Suppression*
5. *Summary and Conclusions*

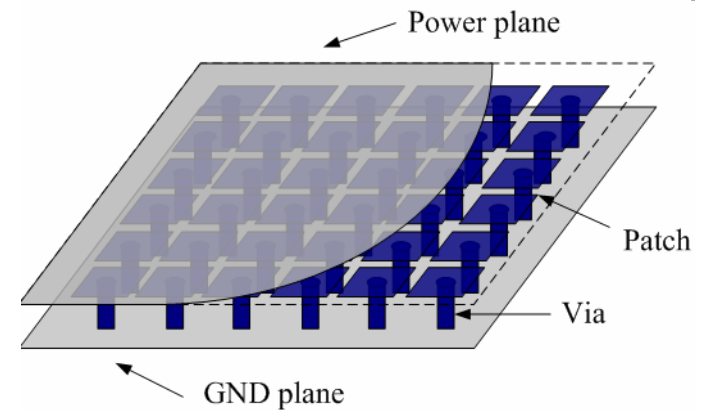
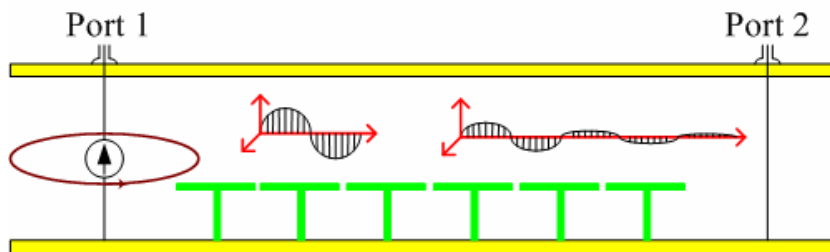

De-Cap. Optimization Combination (1/2)

Decoupling Capacitor Optimization

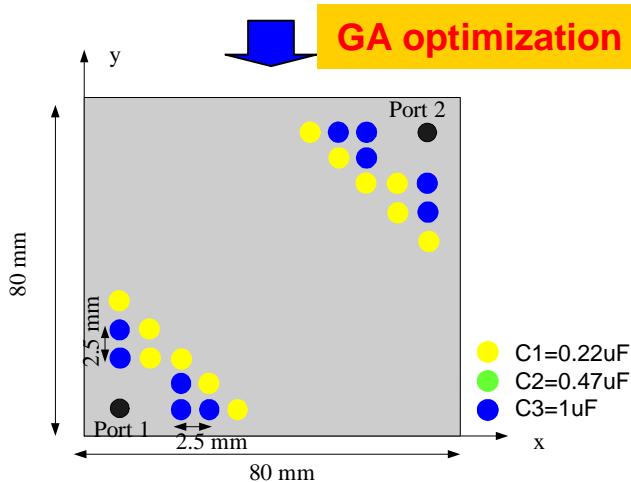
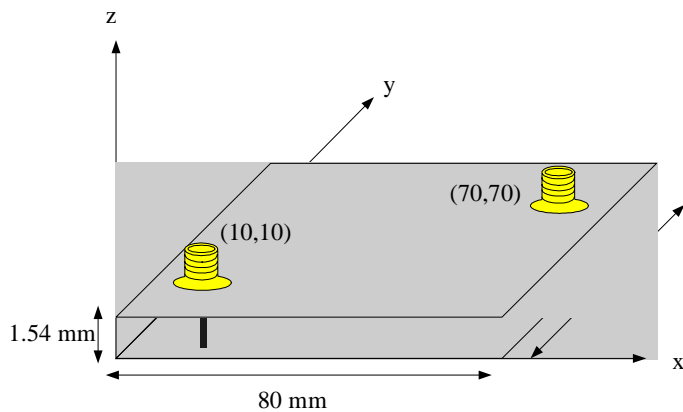

GA optimization [Ref.]

Application:
Use the model below to simulate the frequency behavior of selected TDK MLCCs when performing computerized circuit analysis.

Re: Electrode Resistance
Cp: Capacitance
Rh: Hysteresis Derived Resistance, Rf
ESL: Equivalent Series Inductance
Ri: Insulation resistance

Note: Rh is a function of frequency, it can be calculated by dividing the equivalent resistance (R) in the table below by the frequency of interest.
Ri should be set at 10GΩ at all time.

TC	Case size	Rated Voltage (V)	Cap Value (μF)	TDK P/N	Equivalent Circuit Values			
					Cp (μF)	Re (mΩ)	ESL (pH)	R (MΩ Hz)
X7R/ X5R	C1005 (0402)	6.3	0.22	C1005X5R0J224K	0.22	20.0	600	21.9
			0.47	C1005X5R0J474K	0.47	10.0	600	9.7
			1.00	C1005X5R0J105K	1.00	4.0	600	4.0

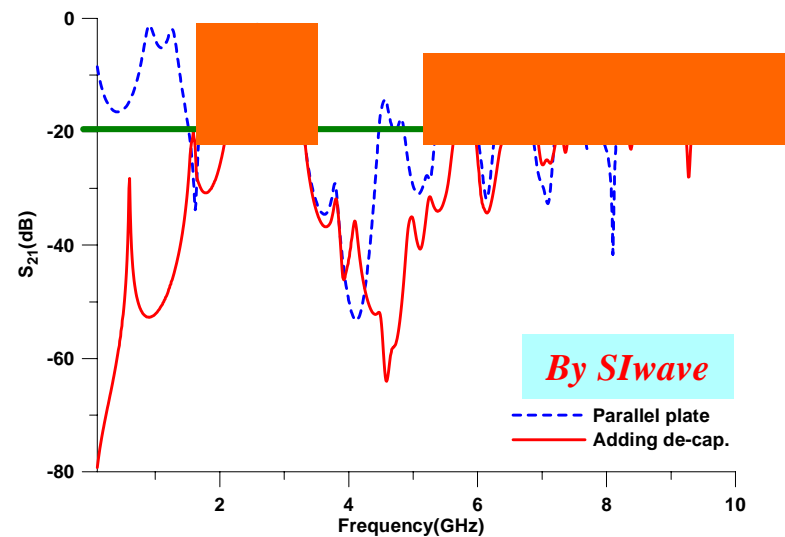

De-Cap. Optimization Combination (2/2)

Decoupling Capacitor Optimization Combined with EBG Structures

By SIwave

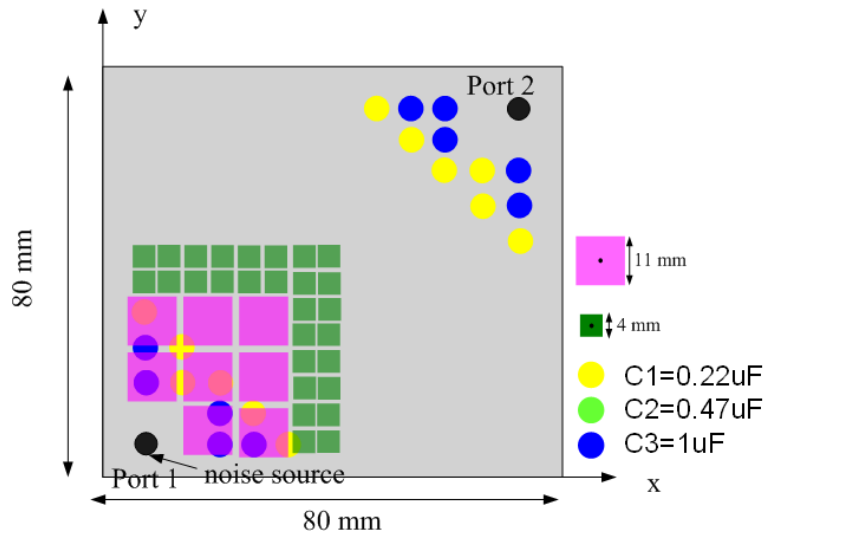

EBG 1

EBG 2

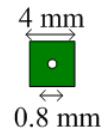
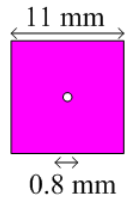

1.8~3.5 GHz

4.8~8.3 GHz

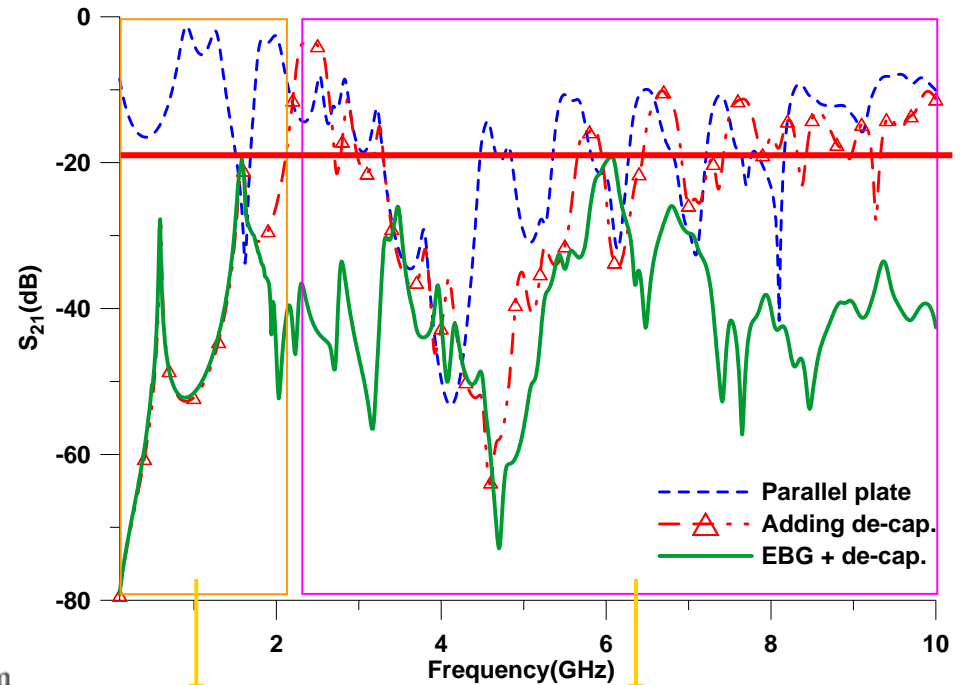

De-cap

EBG

2 GHz<

>2 GHz

Isolation Islands Coupled Noise Suppression(1/3)

Coupled Noise Suppression [Ref.]

$V_s = 0.25V$
 $t_r = 90 \text{ psec}$

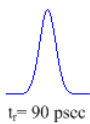
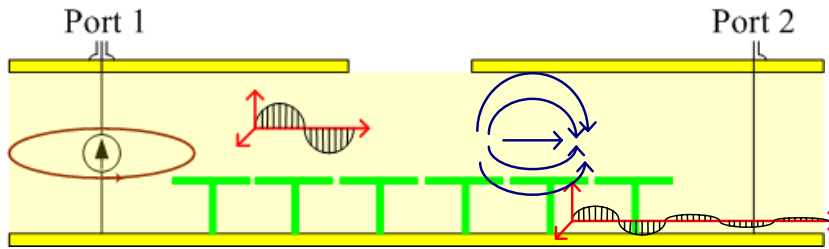
Test Vehicle : Isolation Islands

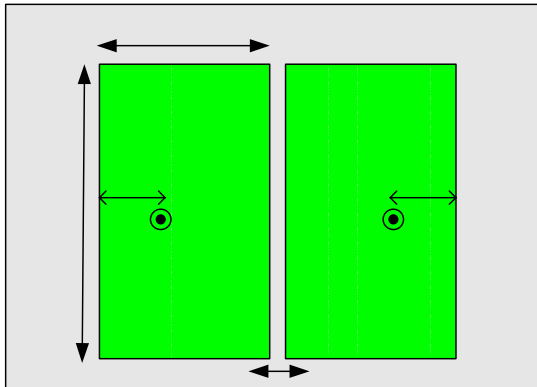

Isolation island are commonly used in PCB to distribute multiple power source or separate noisy circuit areas.

Coupled Noise

$$f_{mn} = \frac{1}{2\sqrt{\mu\epsilon}} \sqrt{\left(\frac{m}{a}\right)^2 + \left(\frac{n}{b}\right)^2}$$

$TM_{10} = 2.3 \text{ GHz}$, $TM_{20} = 4.6 \text{ GHz}$

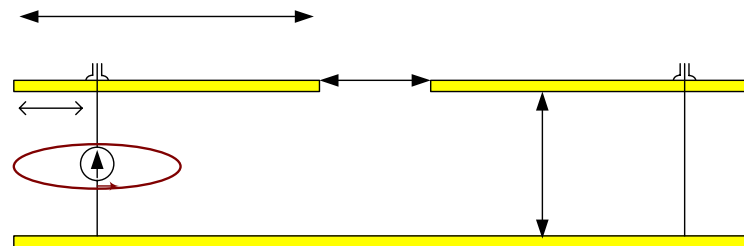

[Ref.] C. T. Wu and R. B. Wu, "Two-dimensional finite- difference time-domain method combined with open boundary for signal integrity issues between isolation islands," *IEEE 11th Topical Meeting Elect. Perform. Electron. Packag.*, pp. 283–286. 2002.

Isolation Islands Coupled Noise Suppression(2/3)

- Coupled Noise Suppression**

By HFSS

$TM_{10}=2.3$ GHz , $TM_{20}=4.6$ GHz

Feeding position: $c=0$

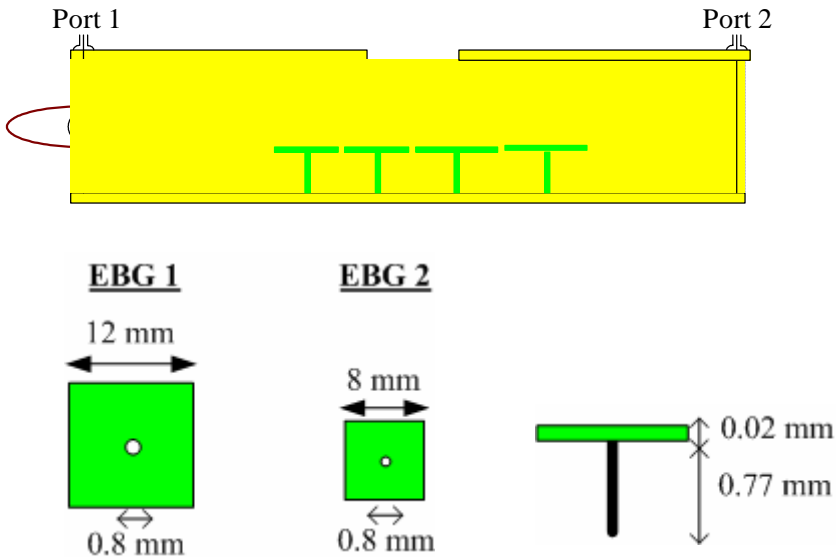

1.6~3 GHz

2.9~5 GHz

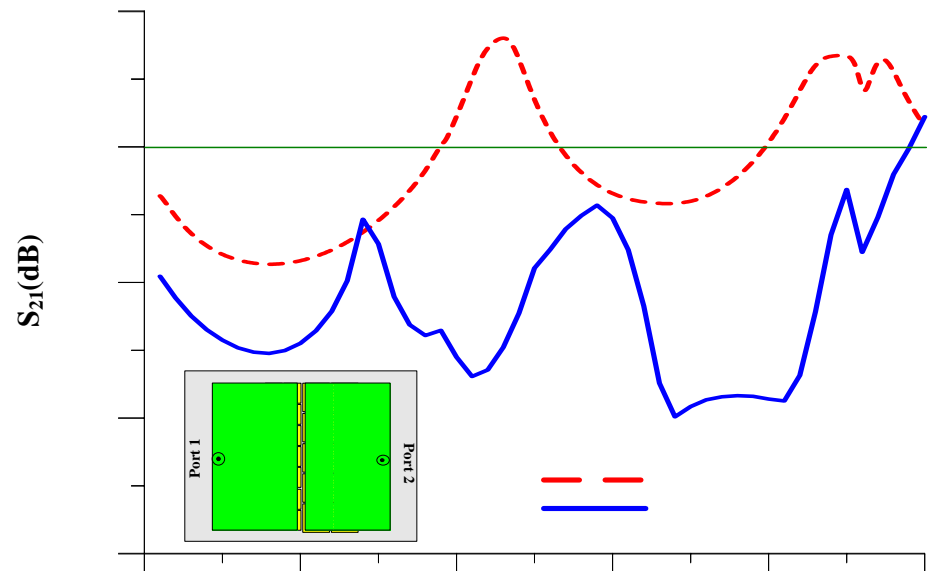

Isolation Islands Coupled Noise Suppression(3/3)

By HFSS

85 % area saved

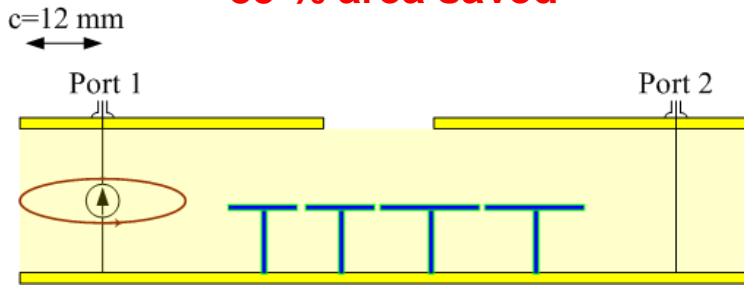

Spiral EBG 1

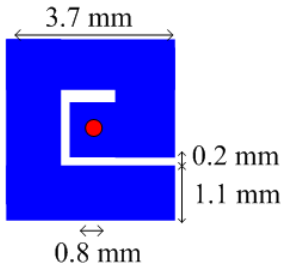

3.4~5.1 GHz

Spiral EBG 2

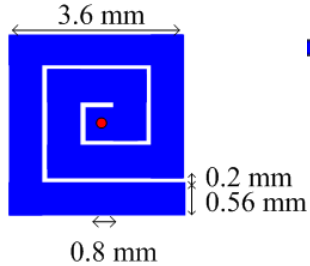

2.25~3.1 GHz

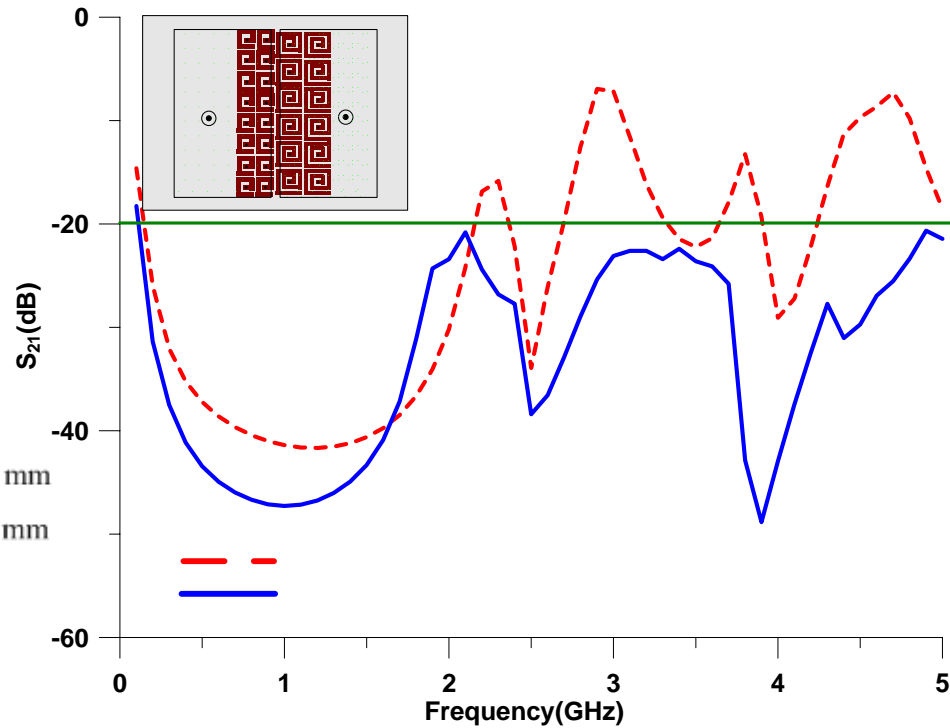
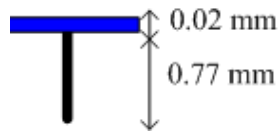

Signal Cross Slot Induced Noise Suppression(1/4)

[Ref.]. C. T. Wu, G. H. Shiue, S. M. Lin, and R. B. Wu, "Composite effects of reflections and ground bounce for signal line through a split power plane," *IEEE Trans. Adv. Packaging*, Vol. 25, pp. 297-301, May 2002.

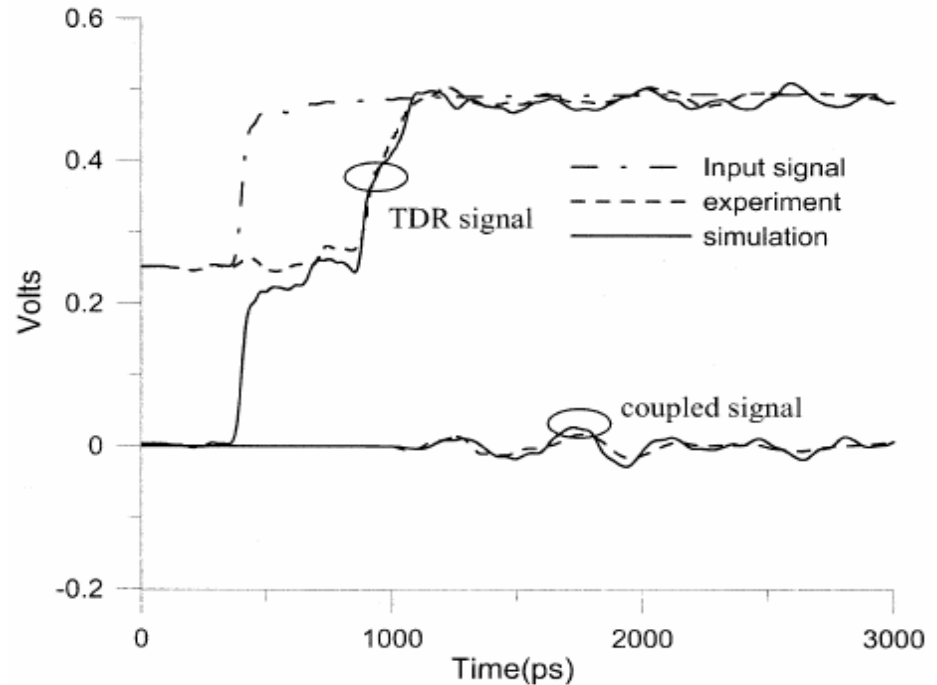
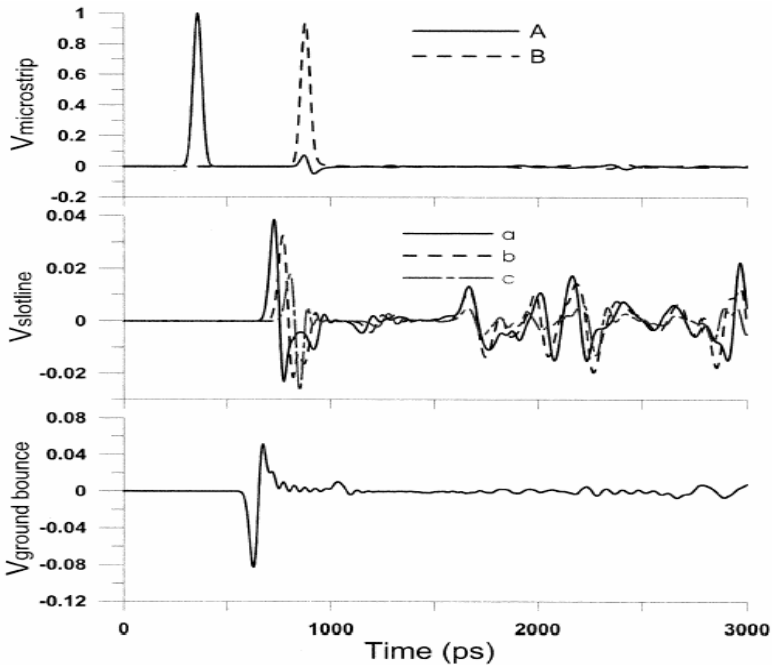
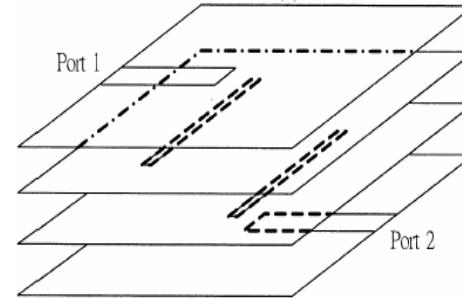
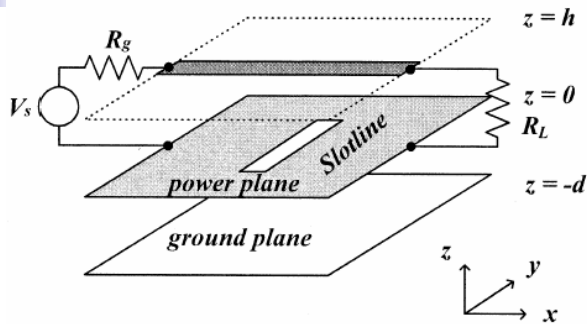

Signal Cross Slot Induced Noise Suppression(2/4)

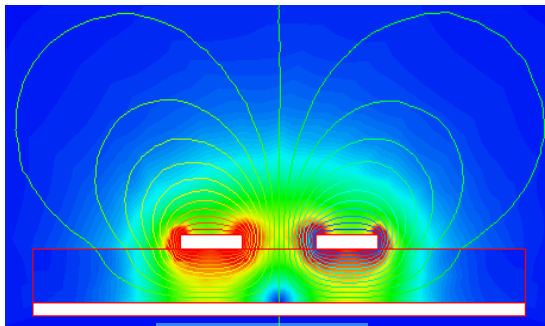
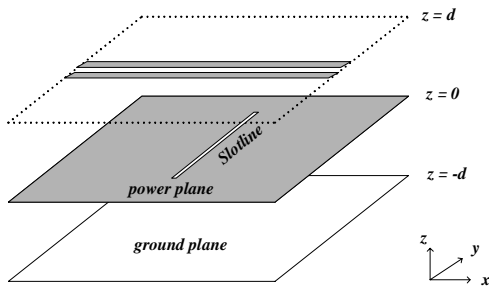
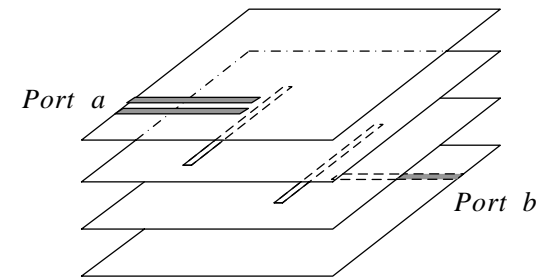

By SI2D

Ref. : G. H. Shiue, S. M. Lin, and R. B. Wu, "Reduction in reflections and ground bounce for signal line through a split power plane by using differential coupled microstrip lines," Proc. IEEE 12th Topical Meeting Elect. Performance Electron. Packag., 2003, pp. 107-110

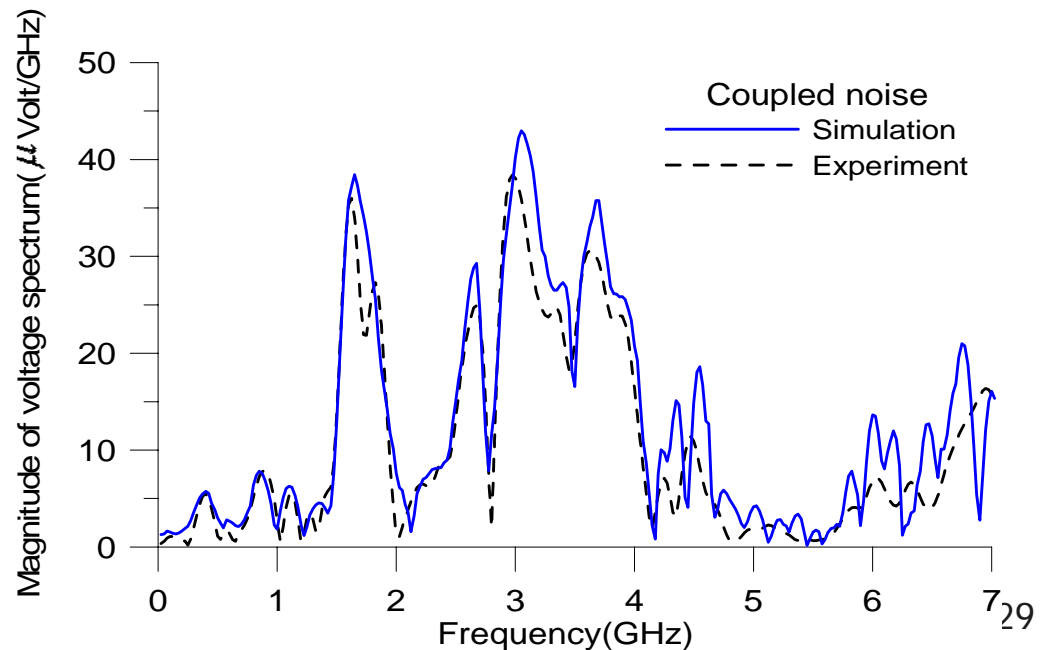
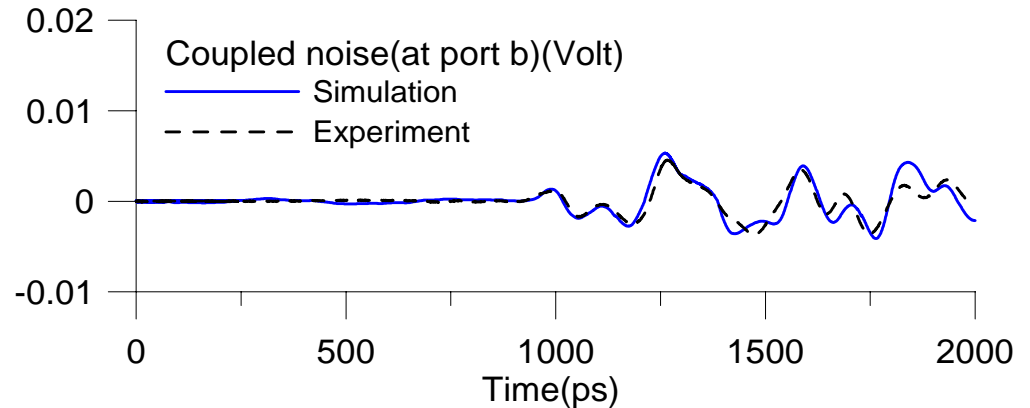

Signal Cross Slot Induced Noise Suppression(3/4)

Signal Line Cross Slot Induced Noise Suppression

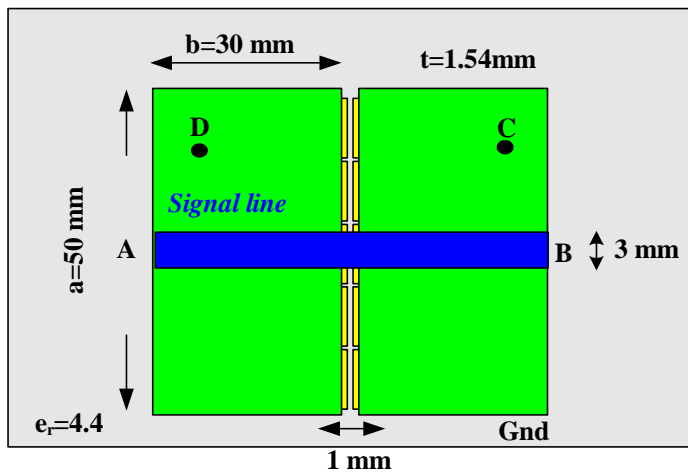
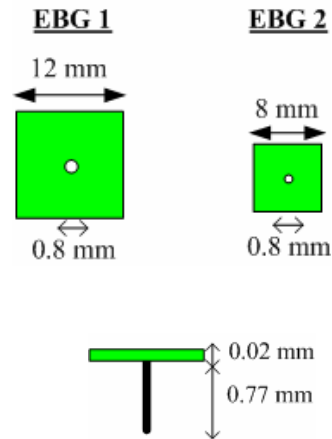
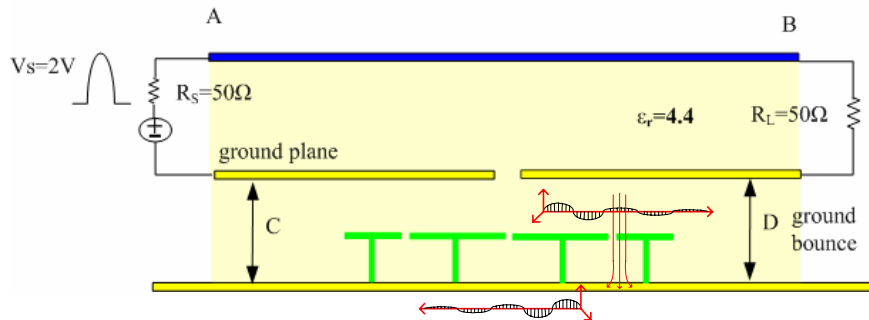

Crossed EBG

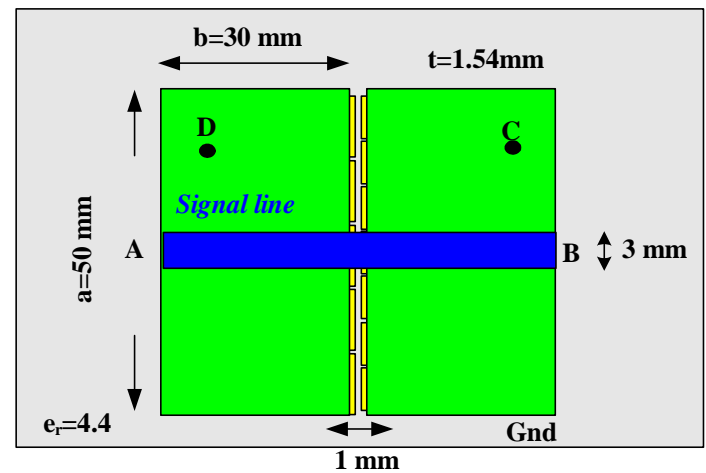

Cascaded EBG

EMI Reduction of Signal Cross Slot

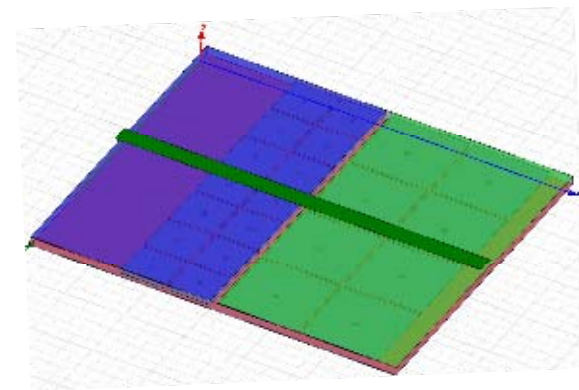
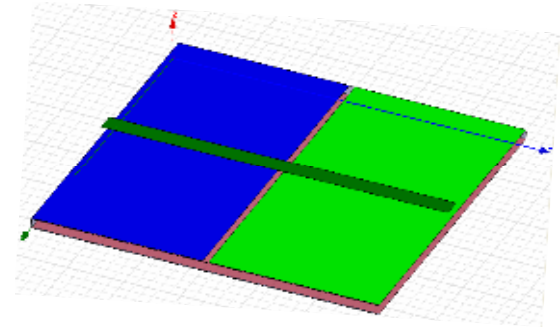
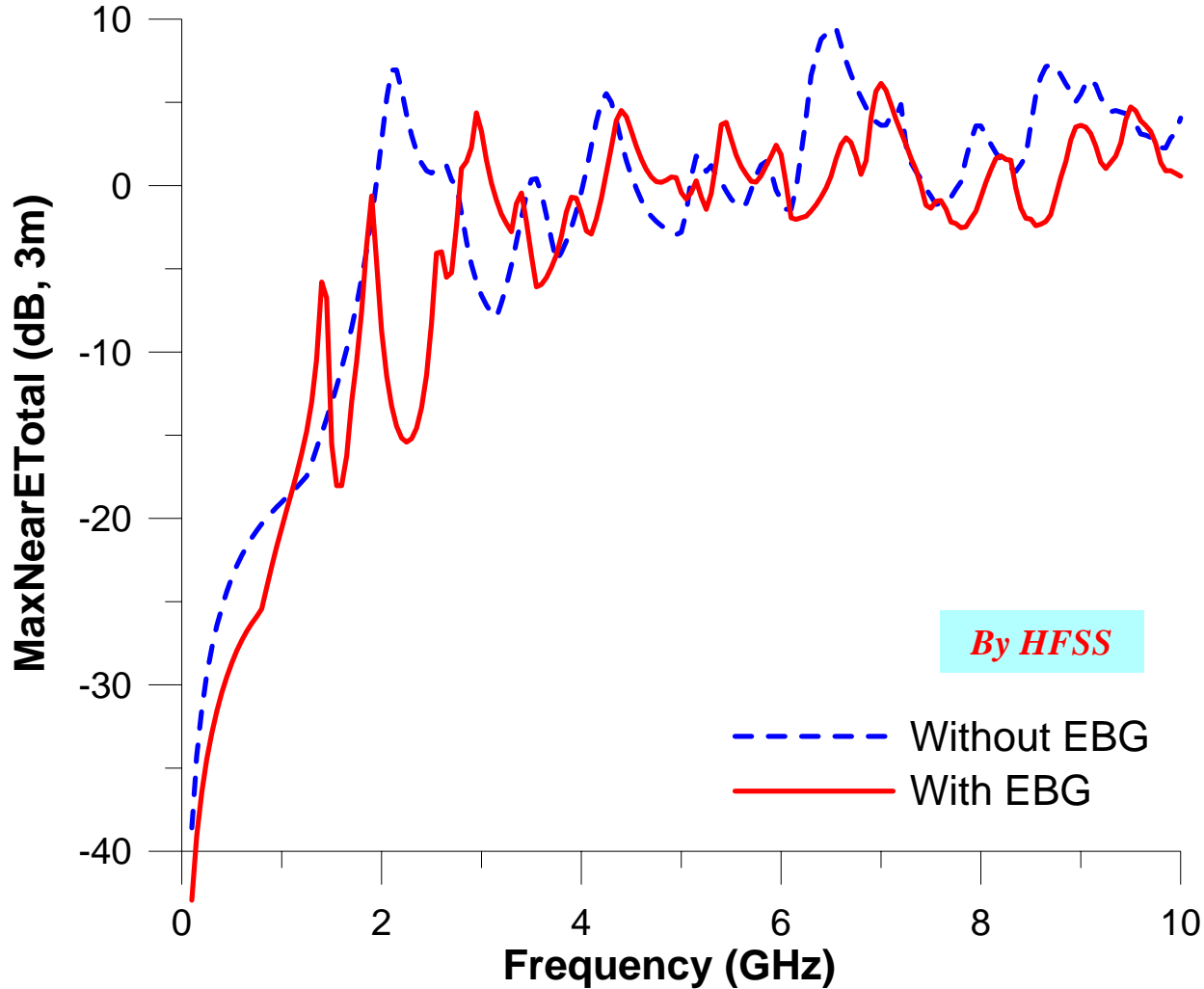

Outline

1. *Motivation*
2. *Introduction to EBG Structures*
3. *Design of Embedded EBG Structures*
4. *Wideband Noise Suppression*
5. *Summary and Conclusions*

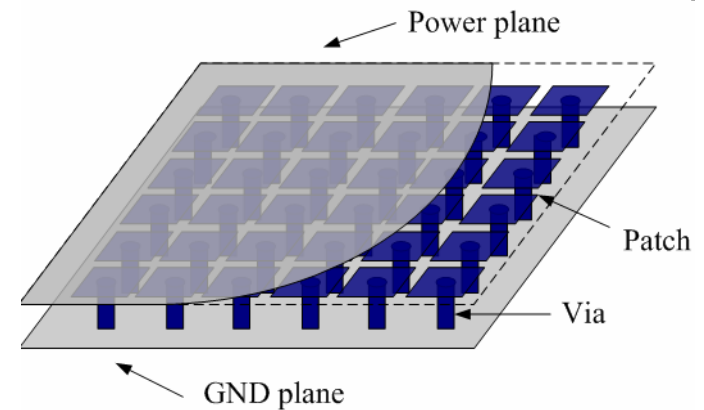
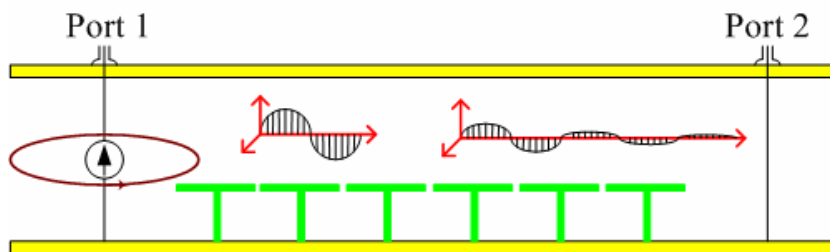

Comparison Table

Good

Bad

EBG Design Consideration		Embedded EBG	
		Patch EBG	Spiral EBG
Convenient		Very Good	Very Good
Layout Area (fc)		Medium	Small
Suppression BW		Medium	Small
Additional Layer		Yes	Yes
Combination (wide-band suppression)	De-cap	Good	Good
	Slot	Good	Good
IR-Drop		-	-
Return Path		Good	Good

EBG

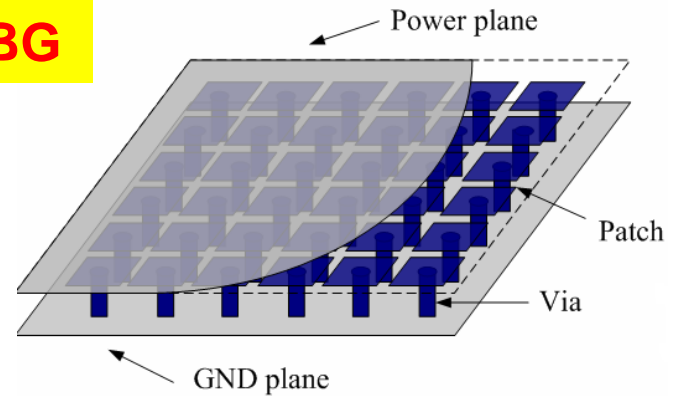

PBG

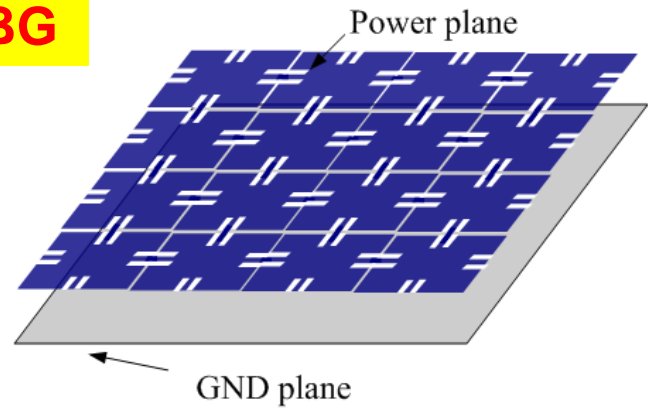

How to implement the structures in practical PCB stack-up ?



6 layers

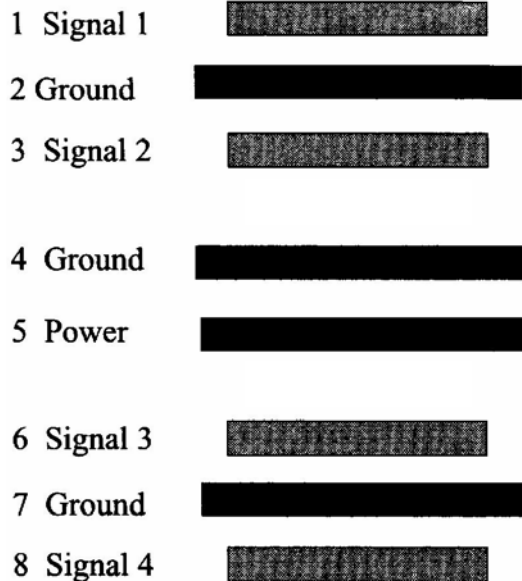

8 layers

EBG

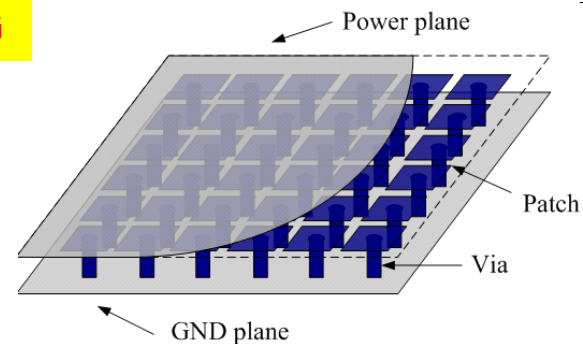

PBG

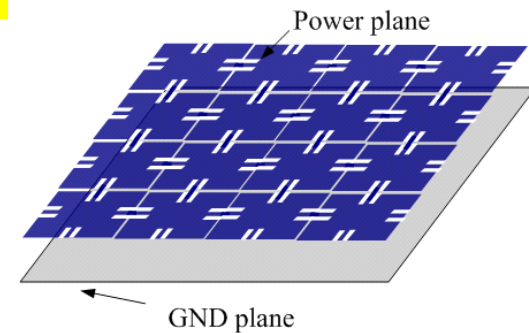

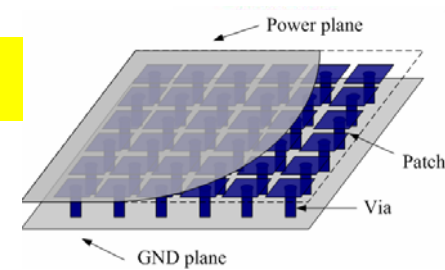

Conclusions

- For the ease and accuracy in the design of embedded EBG structures, the modified design formula of equivalent model, the design formula of stop-band edge, the design diagram of novel compact spiral EBG structures, and the effective layout area of EBG structures are also presented.
- Embedded EBG-enhanced structures for ultra-wide band noise suppression on split power/ground planes, signal line crossing slot and decoupling capacitor combination are proposed.
- A systematic procedure is established and based on which, it becomes more convenient to design EBG structures for suppressing undesired frequencies without resorting to time-consuming full-wave simulator.

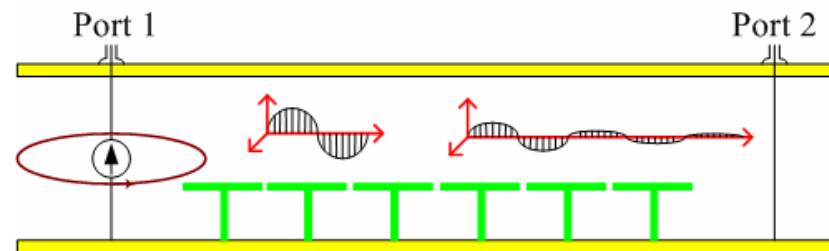

Thank You for Your Attention

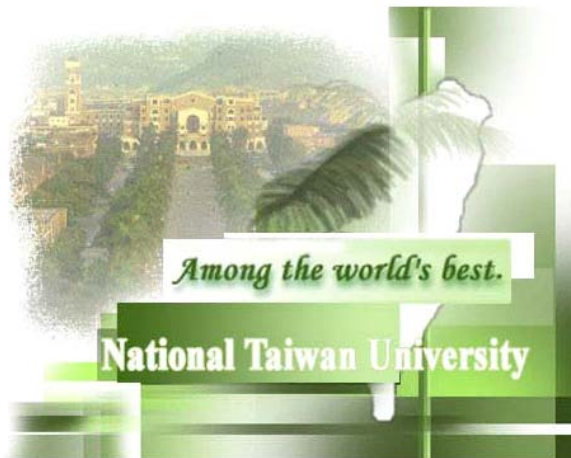

End.....