

Frequency Response Analysis for DC-DC Converters Without Small-Signal Linearization

Kasemsan Siri

Electrical and Electronic Systems Department

The Aerospace Corporation

El Segundo, CA 90245

(310) 336-2931

kasemsan.siri@aero.org

Introduction

■ Familiar Issues:

- Stubborn design flaws
- Schedule slips
- Cost overruns

■ Powerful analysis approach for assisting design and development of power conversion products:

- Converge in timely manner
- Significantly mitigate the above shortcomings

■ Necessities

■ Choices of analysis approach

■ Benefits

Convergence of Product Design

■ Conventional design:

- Heavily dependent on prototyping experimental results
- Verify by frequency response measurements
- Time-consuming to identify or fix design flaws

■ Modernized design:

- Apply modeling & simulation to uncover design performance prior to prototyping
 - verify typical steady-state & transient performance
 - not always uncovering frequency response

■ Advanced design:

- Virtual prototyping through modeling & simulation
- Capable of uncovering frequency response
- Better chance of uncovering flaws before prototyping

Necessities

- **Frequency response analysis tools are necessary for advanced design:**
 - Assist in identifying and resolving design flaws
 - Validate the design prior to hardware prototyping
 - Cost effective
 - Timely complete product development
- **Dilemma of design & test engineers**
 - Avoid analytical modeling
 - Rely on prototype testing (so getting used to)
 - Over simplified testing due to equipment limitations

Analysis Choices

- **Conventional method with small-signal linearization:**
 - Limited to “linearizable averaged” product models
 - Discard parasitic and non-linear effects
 - Quick to get results
- **“Virtual network analyzer” method without small-signal linearization (FFT, Fourier Series)**
 - Also applied to highly non-linear switching models
 - Retain “as is” models as designer’s schematics
 - Significant analysis time but worthwhile

Applicability of Analysis Choices

<i>Analysis Choices</i>	<i>Linearizable Averaged Model</i>	<i>Non-linear Switching Model</i>
Conventional Linearized AC Analysis	✓	✗
Fast Fourier Transformation (Fixed time-step)	✓	✓
Fundamental Extraction from Fourier Series	✓	✓

Analysis, Modeling, and Simulators

Analysis Approaches	Linearized AC
	FFT
	Fourier Series
Modeling Schemes	Linearizable Averaged Models
	Non-Linear Switching Models
Simulator Platforms	Circuit-Oriented
	Control -Oriented

FFT ANALYSIS on Control-Oriented Simulator

- **FFT frequency response analysis without small-signal linearization**
 - **No need to use approximated models**
 - **Extract frequency response directly from simulated time-domain signals**
- **Control-oriented simulators offer more flexibility**
 - **Use of programmable SCRIPT files, allowing**
 - **repetitive simulations & data acquisition,**
 - **repetitive & programmable FFT processing .**

Converter System with Signal-Injection for Loop-Gain Response Analysis

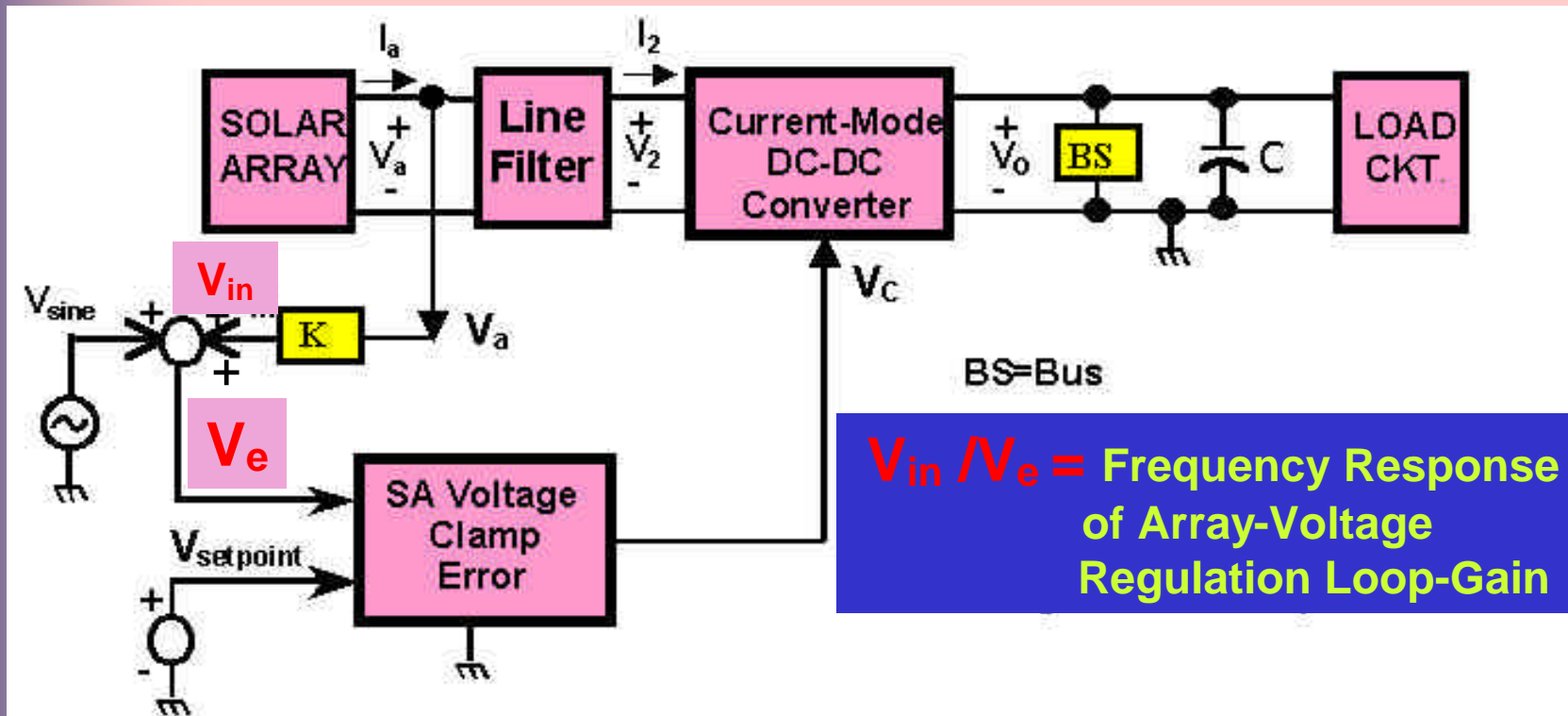

Control-Oriented Large-Signal Modeling

- Modeling in control-oriented simulators requires overhead analytical effort,
 - to convert circuits into control blocks.
- The control blocks derived from circuits can be
 - interconnected transfer functions and/or
 - linked sets of state and output equations
 - which are formatted in vectors and matrices.
- Achieve control-oriented power system model by
 - combining all derived control-oriented models and
 - connecting them together.
- Simulate & verify the system model in time-domain before frequency response analysis.

Non-Linear Switching Model of the Power Converter & Control System

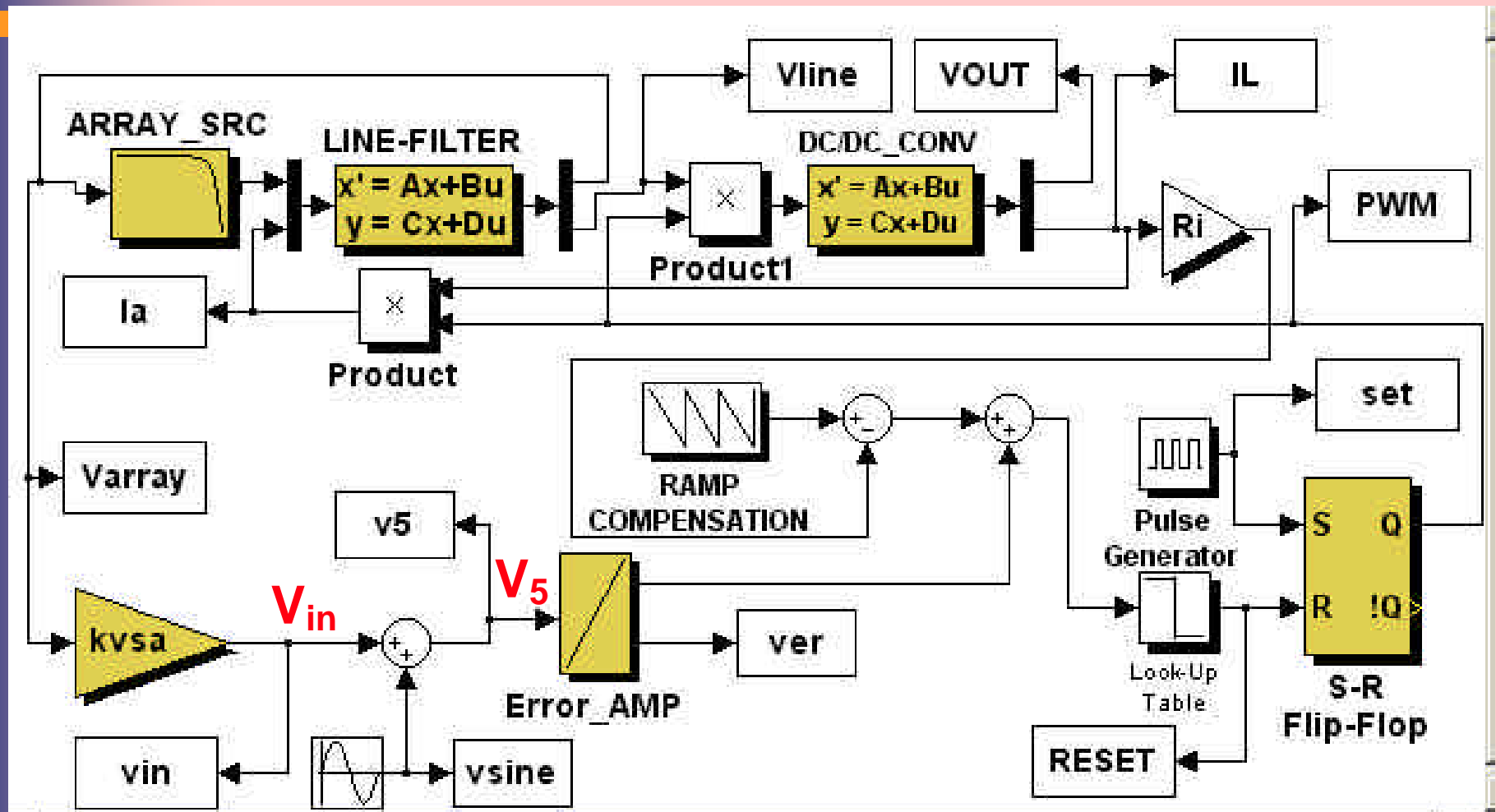

Find $V_{in}/V_5 = ?$

FFT Analysis Flow Charts

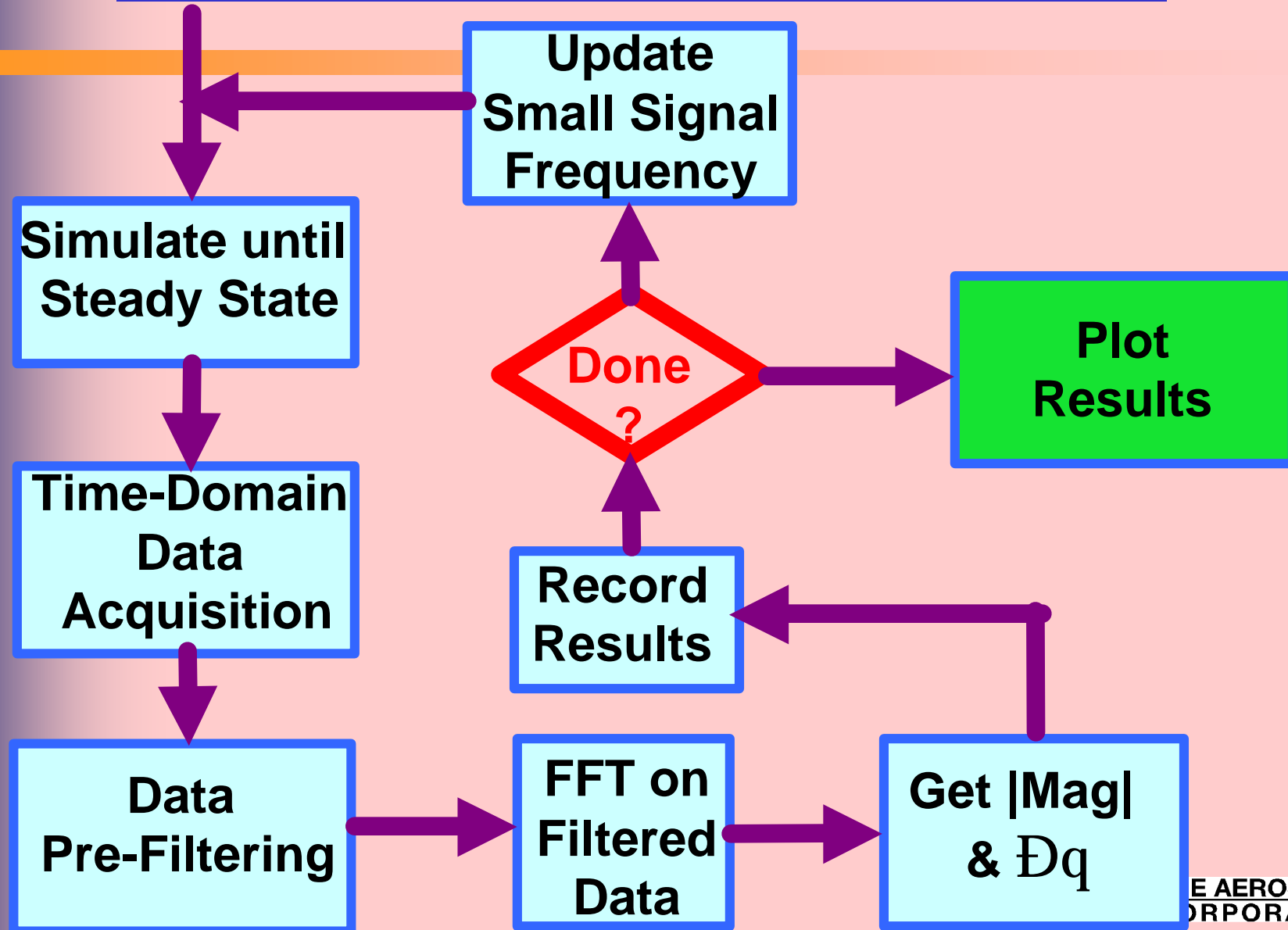

Well Correlated Results from Both Large-Signal Averaged and Non-Linear Switching Models

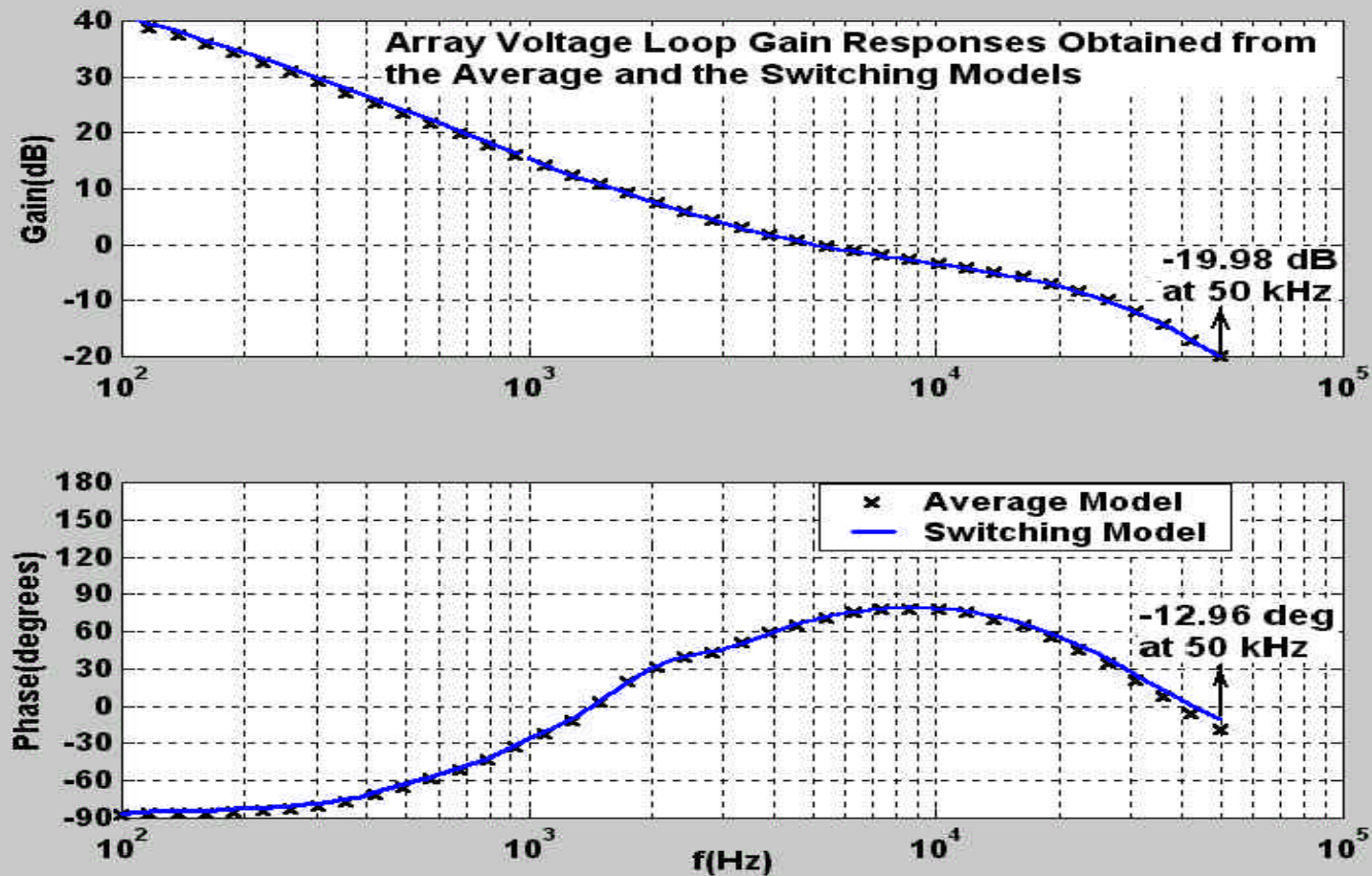

FFT works well for both averaged and non-linear switching models developed in a control-oriented simulator

Circuit-Oriented Non-Linear Switching Model for Loop Gain Extraction (SIMPLORER)

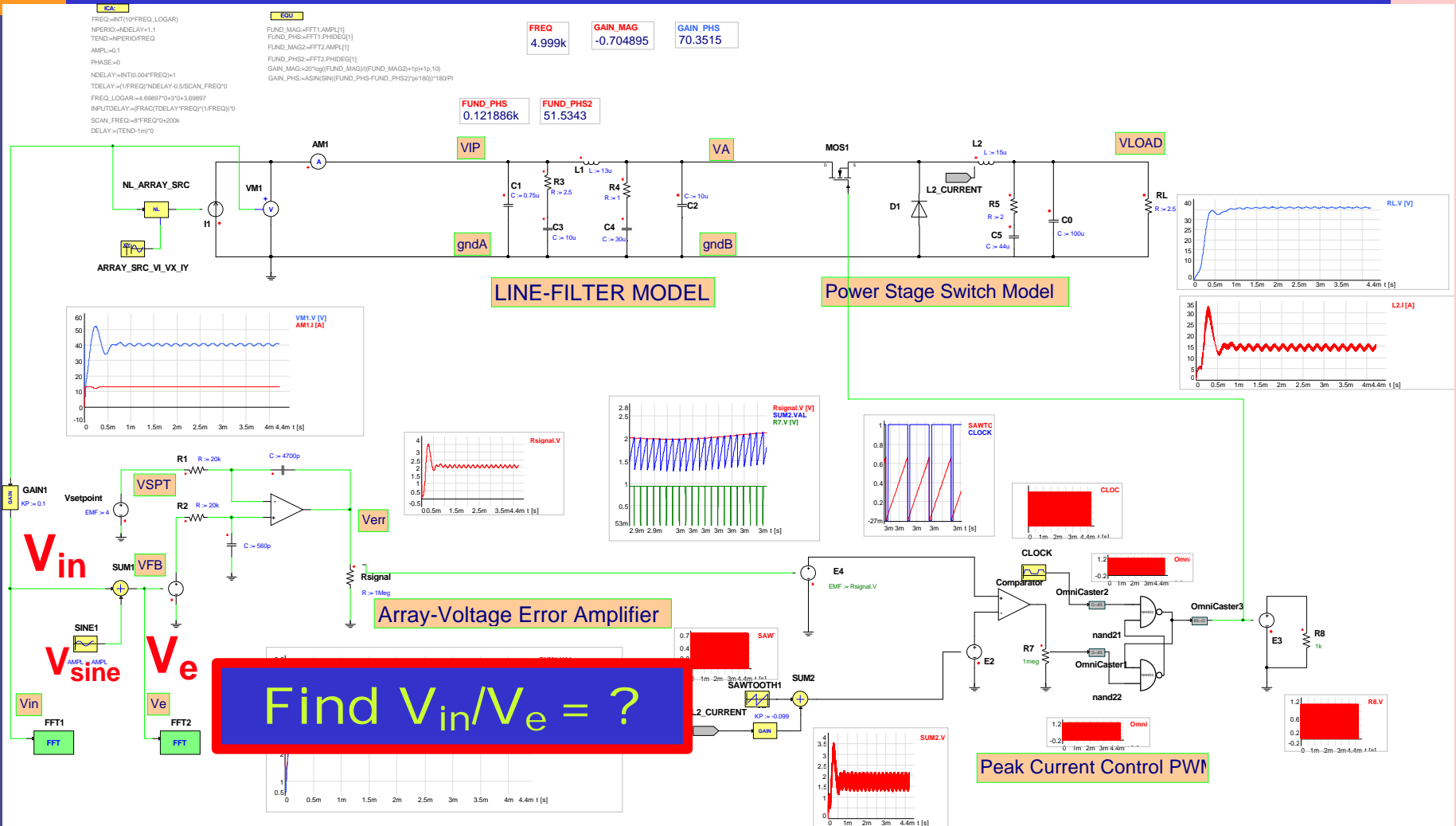

Excellent Correlation Between SIMPLORER Simulation and PSPICE Test Data

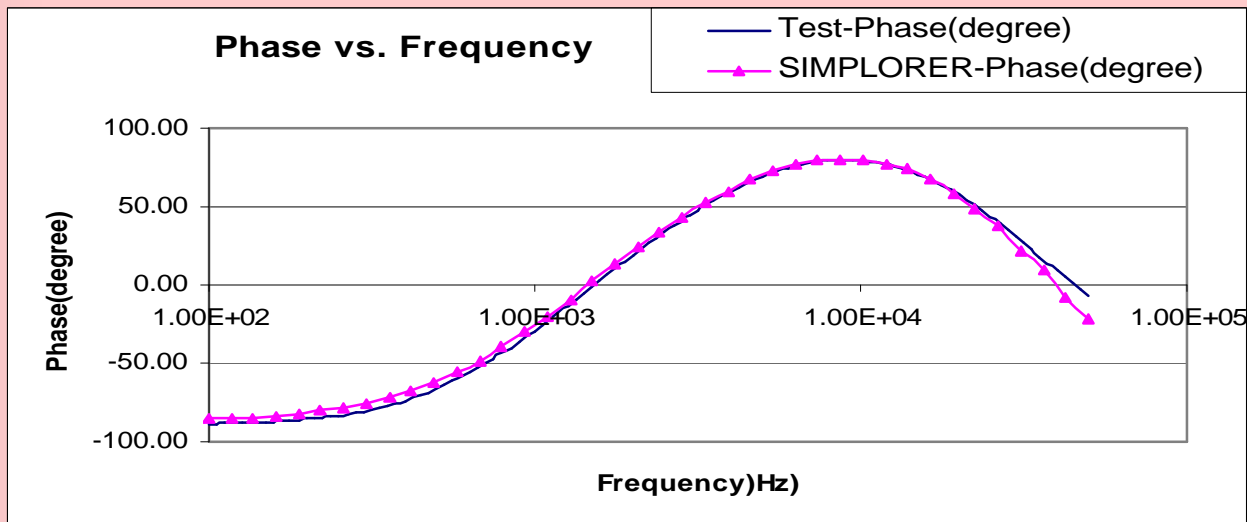
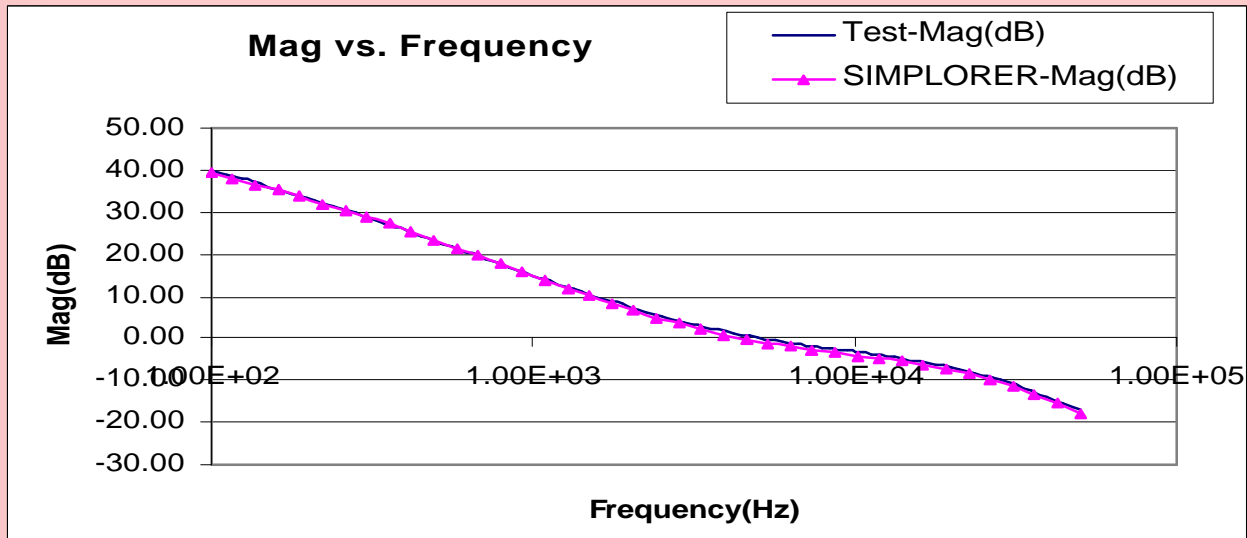

FOURIER ANALYSIS APPROACH USING CIRCUIT-ORIENTED SIMULATION

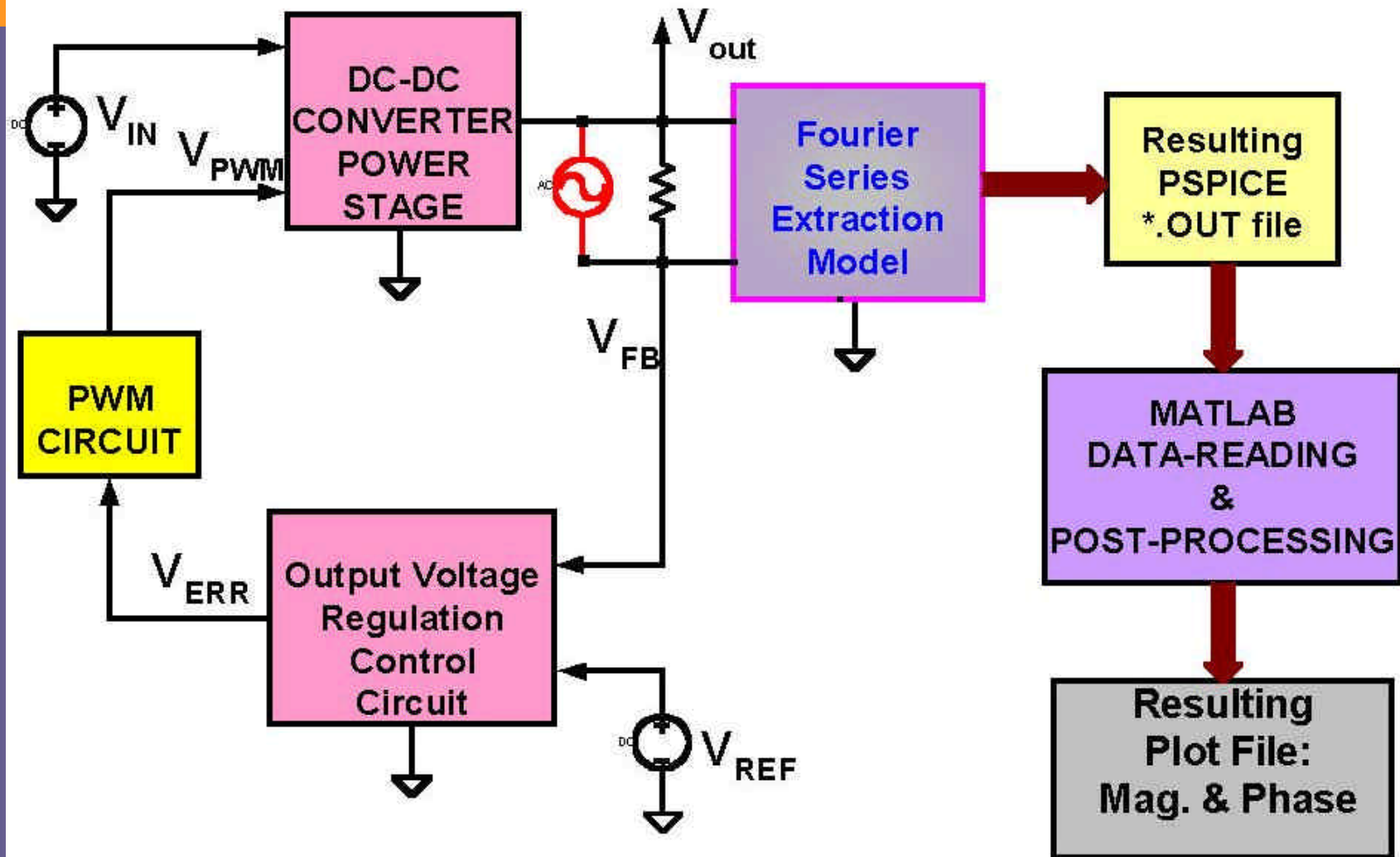

FOURIER EXTRACTION ALGORITHM

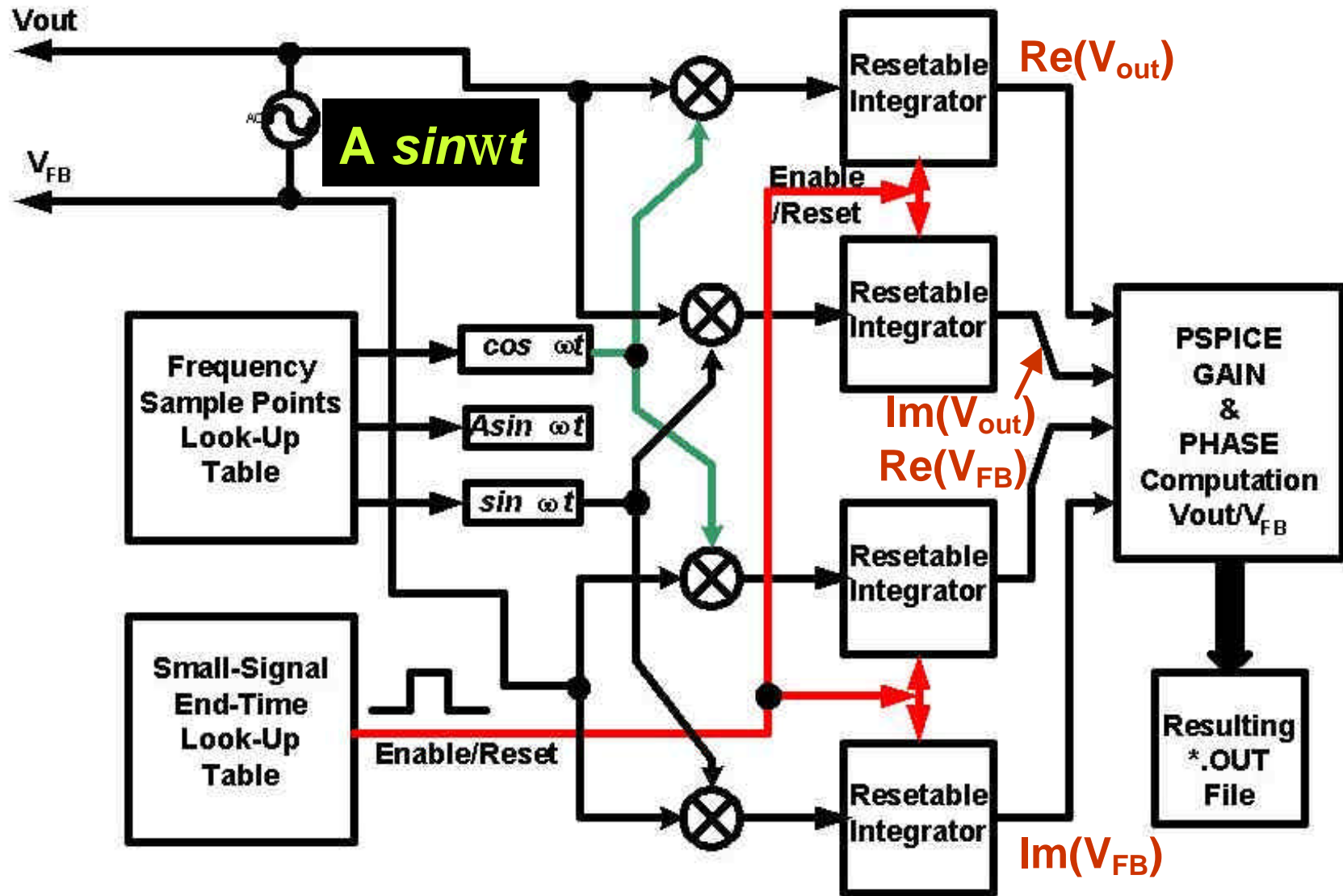

Loop-Gain Response from Two Different Circuit-Oriented Analysis Approaches

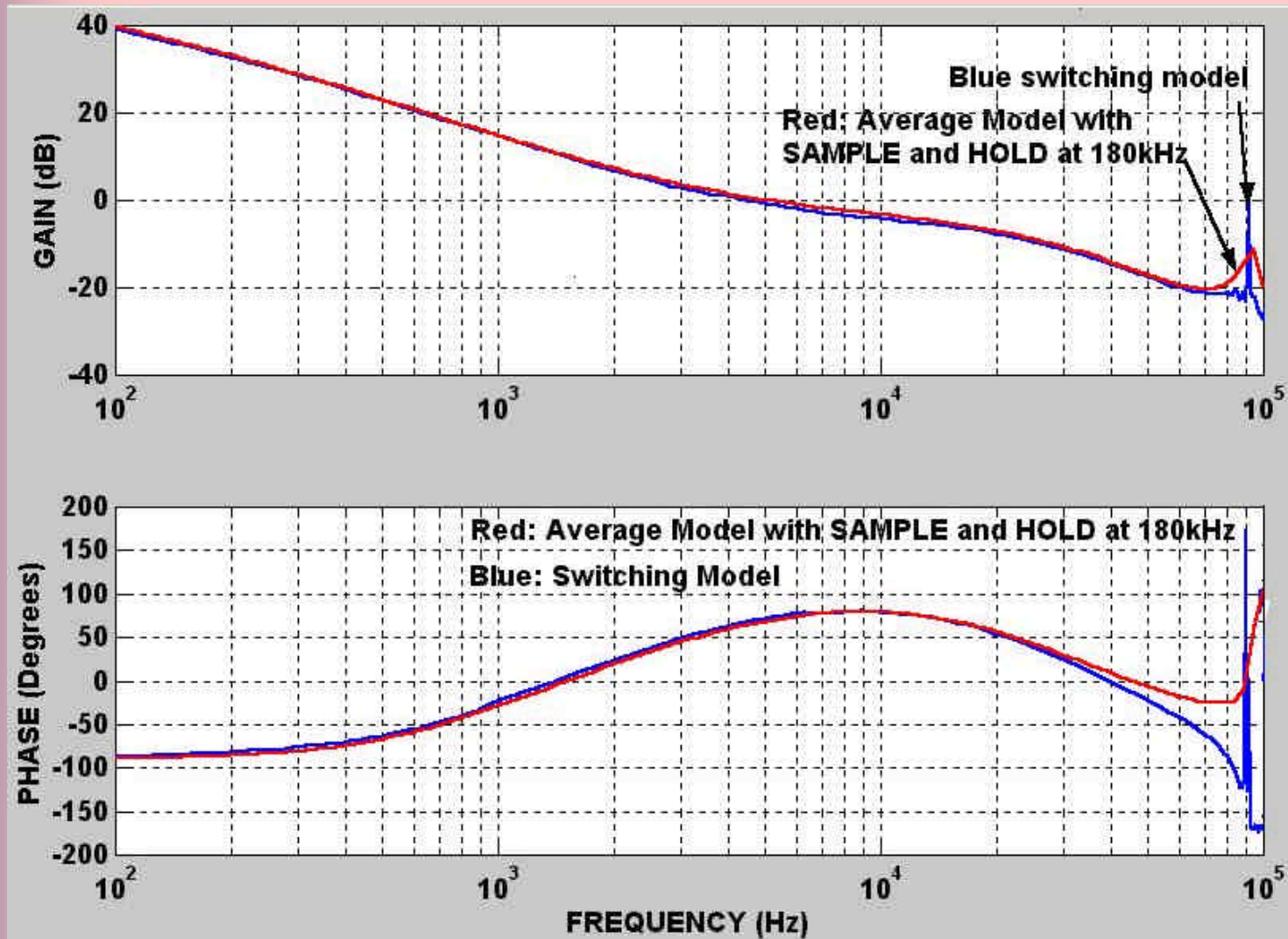

Benefits of Linearization-Free Analysis

■ Extended accuracy including:

- Non-linear effects
- Parasitic components
- retaining “as is” circuit behavior like “virtual prototype”

■ Modeling simplicity:

- No need for overhead analytical effort in deriving linearizable averaged model
- Direct construction of “as is” models from schematic circuit diagrams

■ Applicable to larger classes of product design

- Particularly, DC-DC converter systems of which linearizable models are not available.

Conclusion

- **FFT or Fourier-series analysis is applicable to converter system models being developed in both control-oriented and circuit-oriented simulators, offering**
 - Repetitive simulation runs & programmable data processing
 - Flexible choices of large-signal modeling & simulation platforms:
 - Pulse-by-pulse non-linear switching model
 - Large-signal averaged model
 - Retention of the system non-linearities and parasitic effects
- **‘Virtual network analyzer’ is necessary for switch-mode DC-DC converter systems of which the linearizable averaged models are not available.**
- **The powerful analysis tool offers:**
 - Modeling simplicity,
 - Direct application to the time-domain response, and
 - Extended accuracy of the extracted frequency response

Acknowledgement to Contributors

- **John Kooker:** University of California at San Diego
 - Production of the test converter model in SIMPLORER
- **Jason Ly:** The Aerospace Corporation
 - Application of FFT and data plotting using MATLAB Script files
 - Co-simulation between MATLAB & SIMULINK