

Free-Piston Stirling Converter Controller Development at NASA Glenn Research Center

Timothy Regan
Sest, Inc.

Concept

- Stirling Radioisotope Generator (SRG) Application

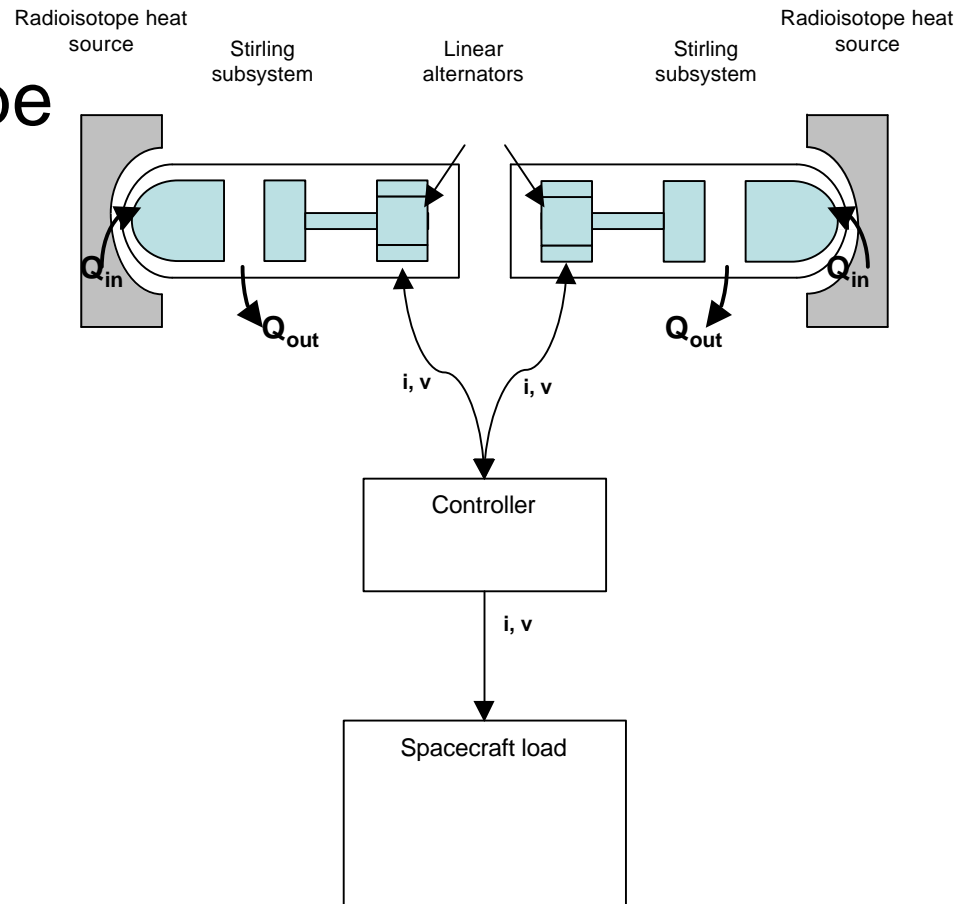

Concept

- Terrestrial generators modulate the fuel to keep frequency constant

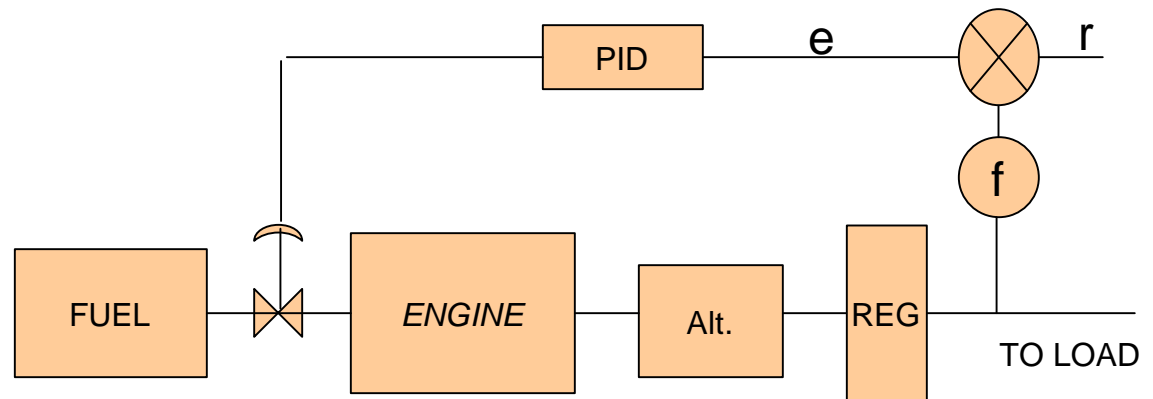

- Terrestrial generators regulate the alternator excitation to keep voltage constant

Concept

- SRG application uses constant Q_{in}

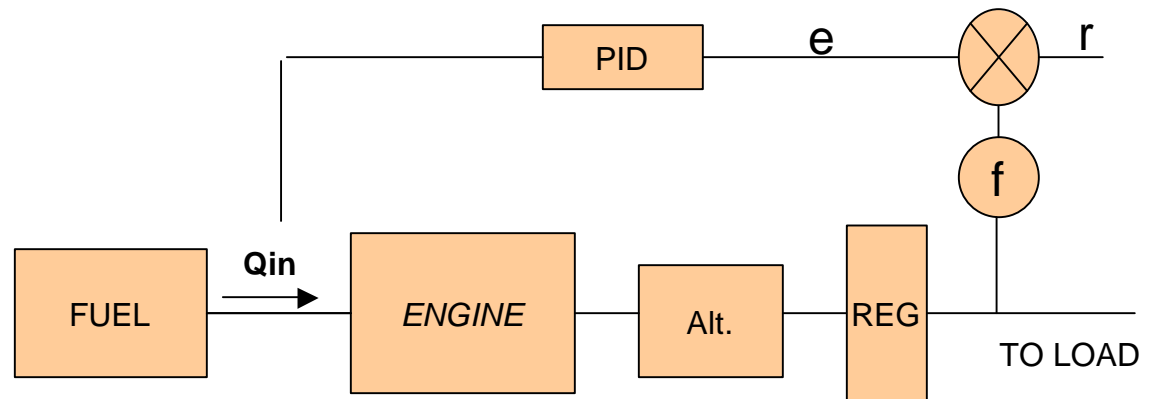

Concept

- SRG application uses permanent magnet alternators with no means to control alternator excitation

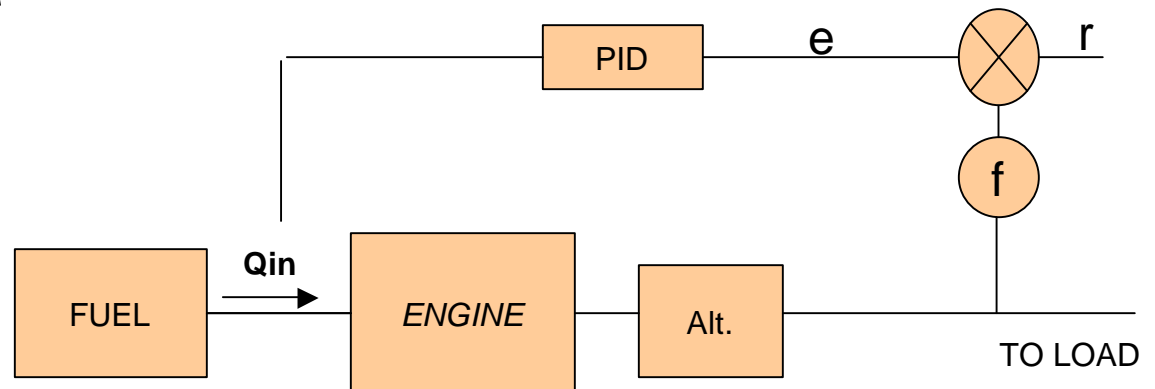

Concept

- In SRG application, total load is kept constant by adjusting parasitic load

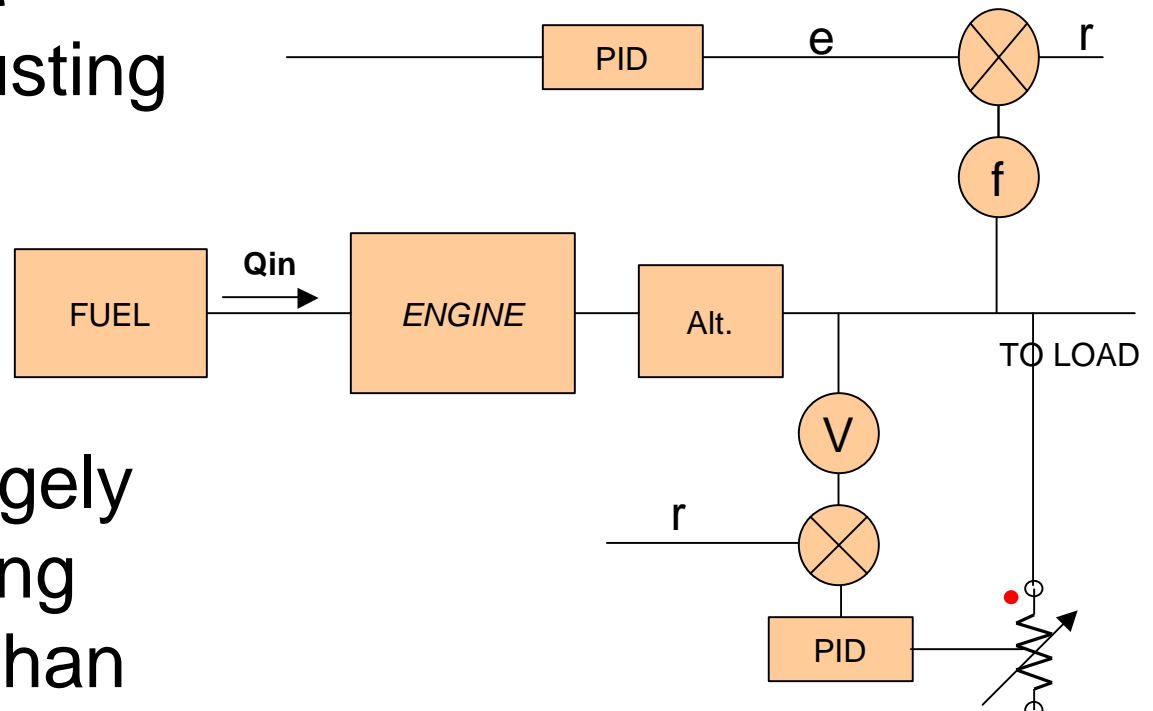

- Frequency is largely dictated by Stirling dynamics (less than 1% variation)

Concept

- Equilibrium operation where load power crosses engine power

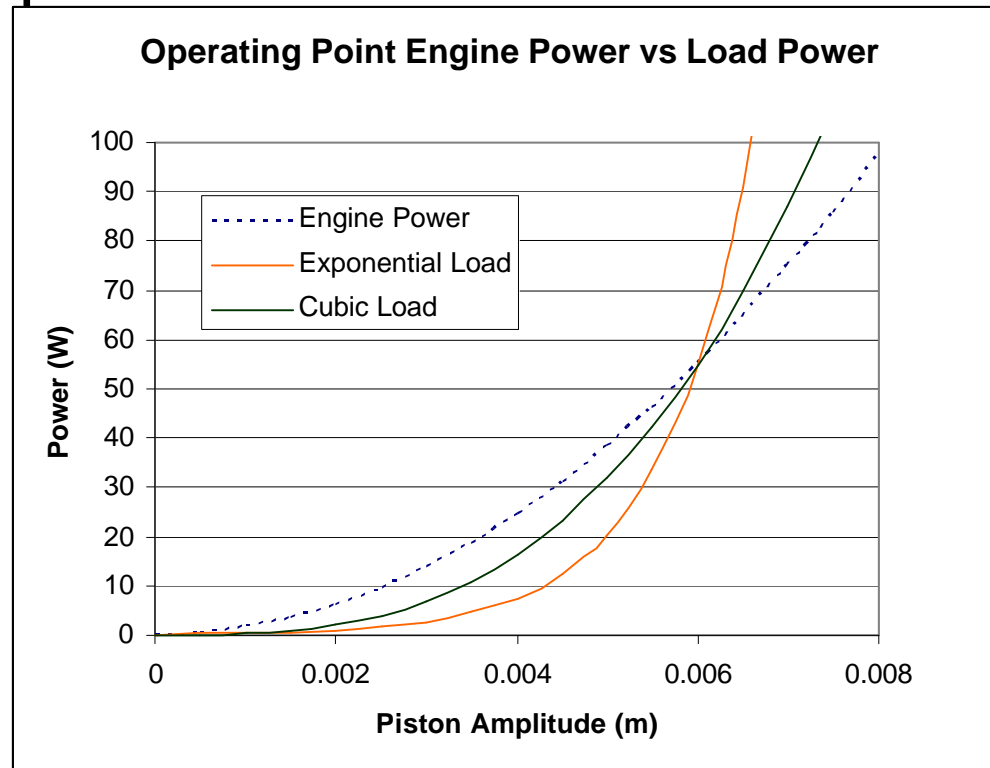

Simplorer Model

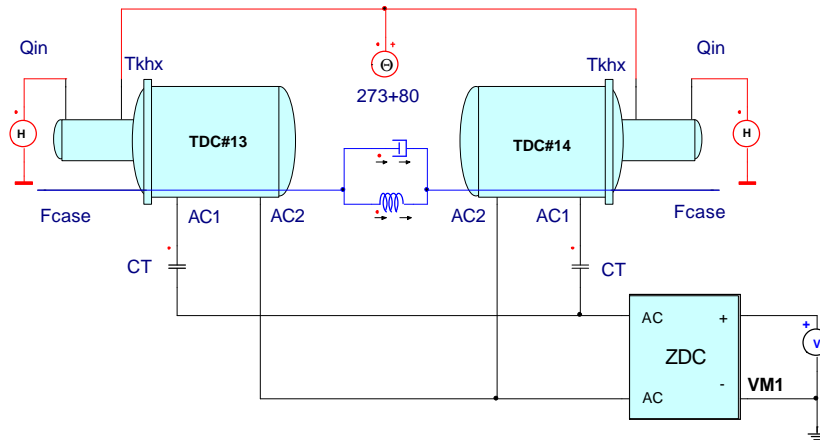
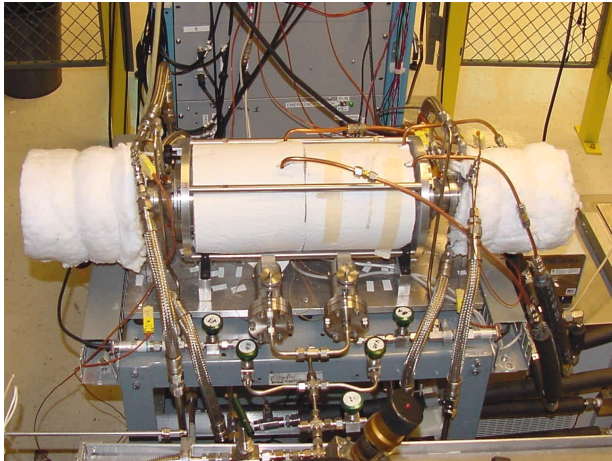

- Used Simplorer simulation software
 - ODE's
 - Thermal
 - Mechanical
 - Electrical/electronics
- Simplorer model allows multiple convertors
- Variety of controllers

Simplorer Model

- Open loop start-up transient response helpful in controller design.
- Disturbance rejection

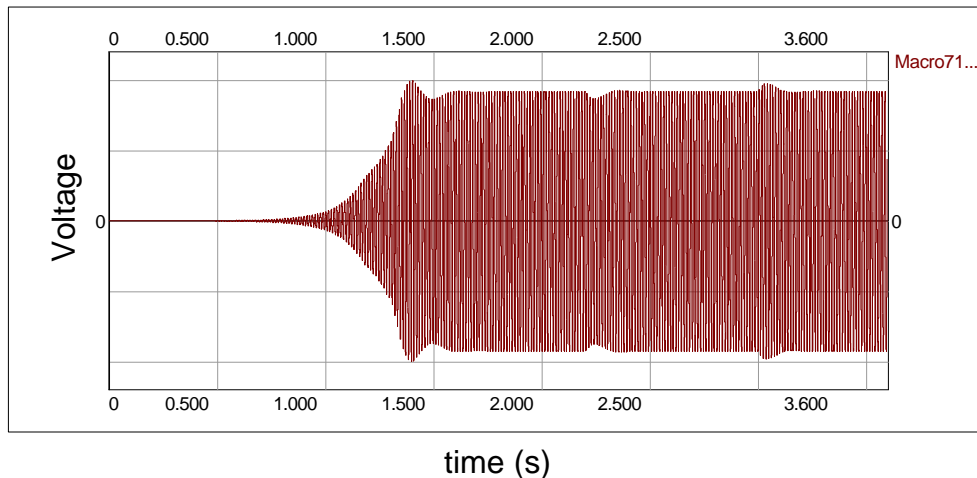
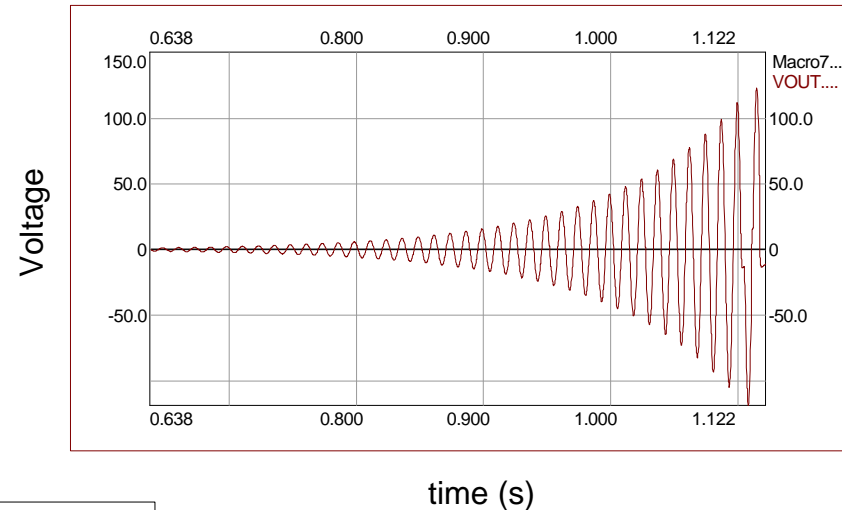

Controllers

1. STC Zener Diode Controller
2. GRC Digital Controller (SP-100 Heritage)
3. GRC 2nd Generation Digital Controller
4. GRC Advanced Controller (P-F correcting/PWM)

1. Zener Diode Controller

- Zener
 - reference voltage
 - Measures the V_{dc}
 - Load applied when $V_{dc} > V_{ref}$
- Looks at instantaneous V_{dc}
 - No memory of last half cycle

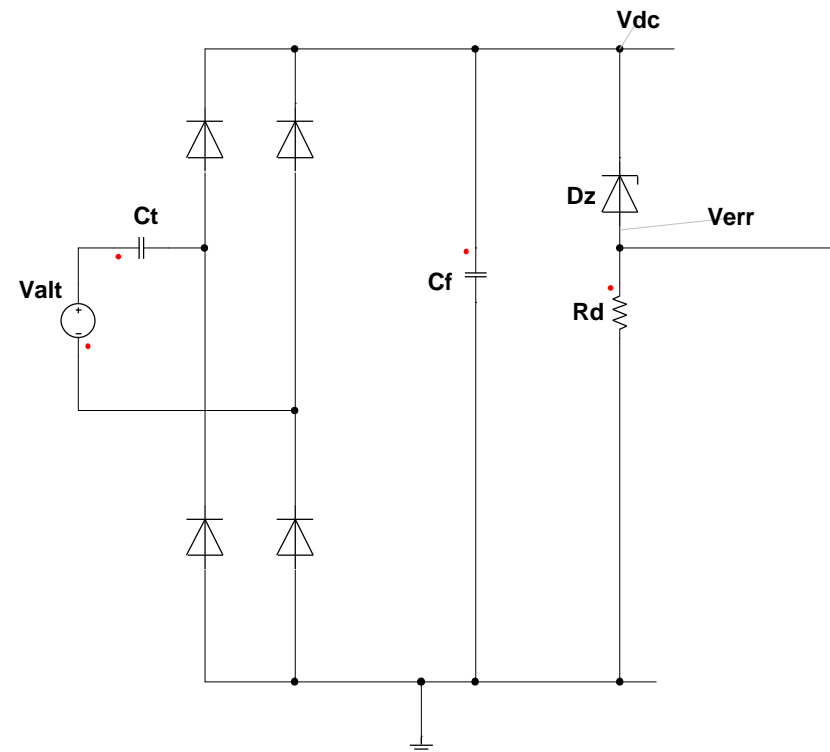

1. Zener Diode Controller

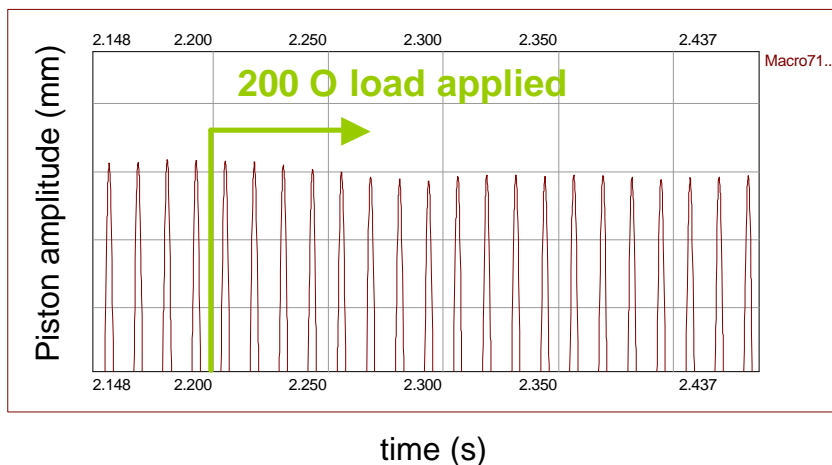
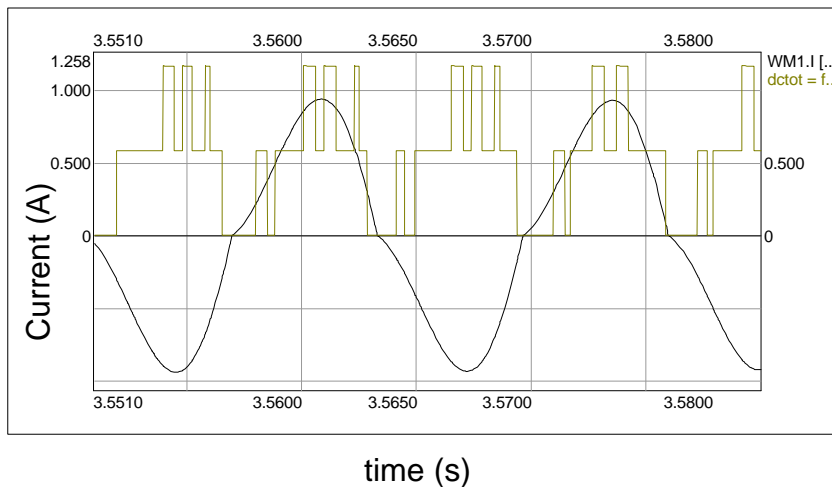

- Parasitic resistance applied to DC bus
- Rectifier
 - DC load can occur anytime during the cycle
 - AC load (stator current) always centered about V_{peak}

1. Zener Diode Controller

- Maintains constant output voltage over wide range of output power

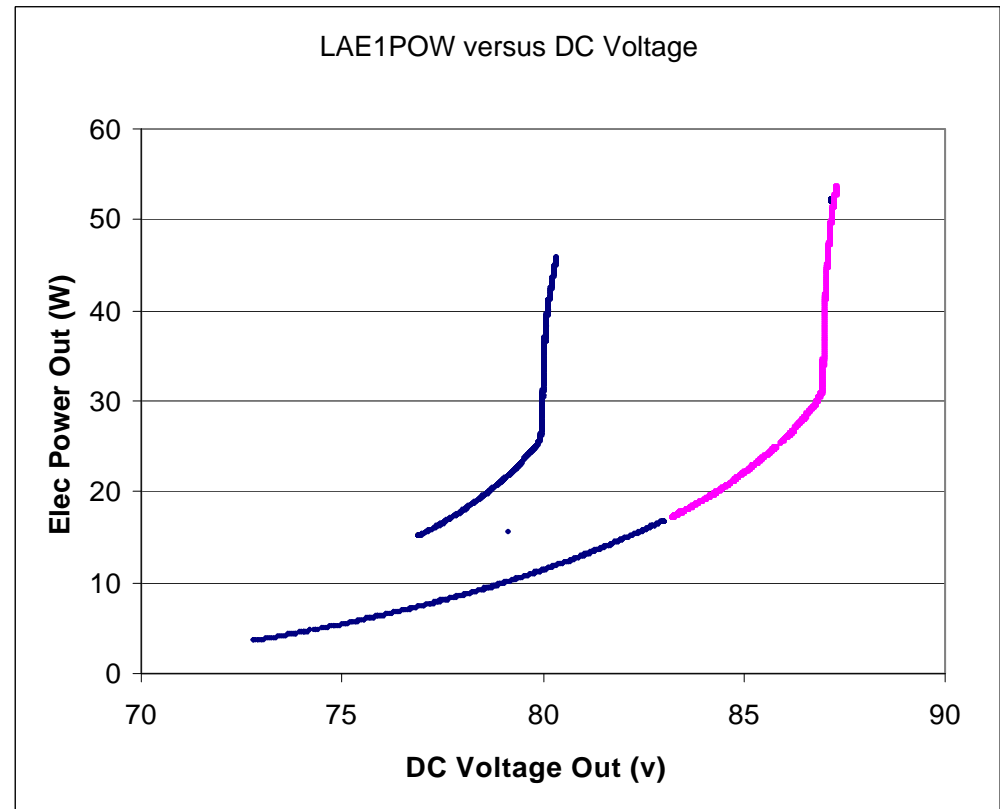

2. GRC Digital Controller

- Applies parasitic load to AC bus
- Voltage-controlled resistor load
- Produces characteristic that crosses convertor characteristic at a sharp angle

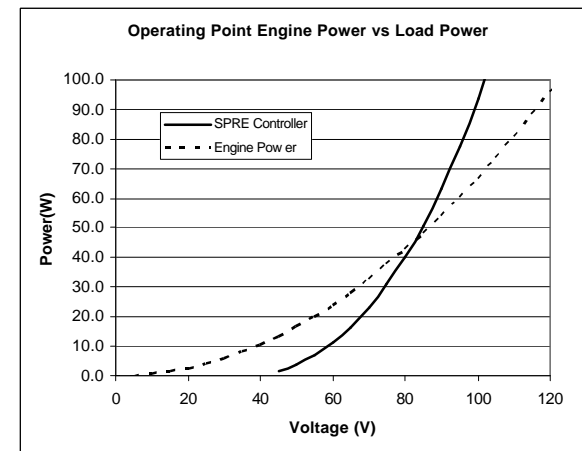
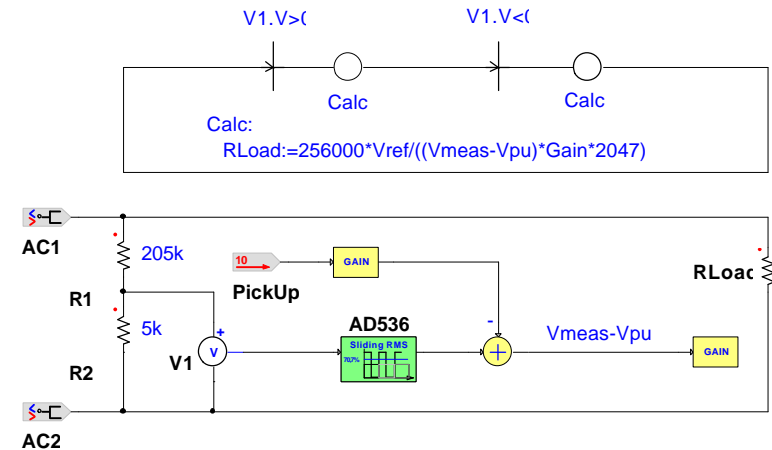

2. GRC Digital Controller

- Applies parasitic load to AC bus
- Voltage-controlled resistor load
- Produces characteristic that crosses convertor characteristic at a sharp angle

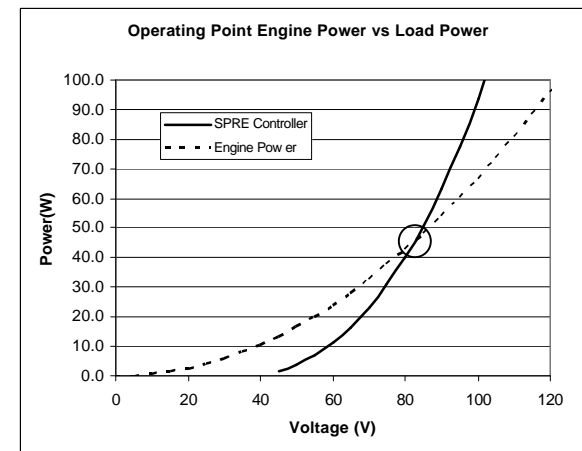
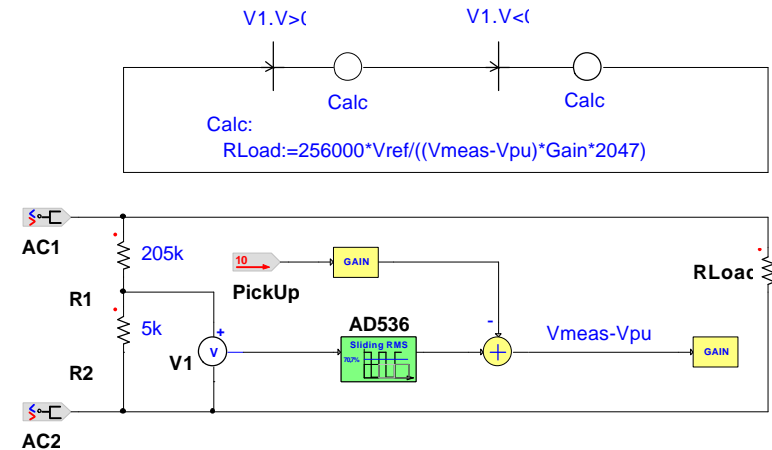

2. GRC Digital Controller

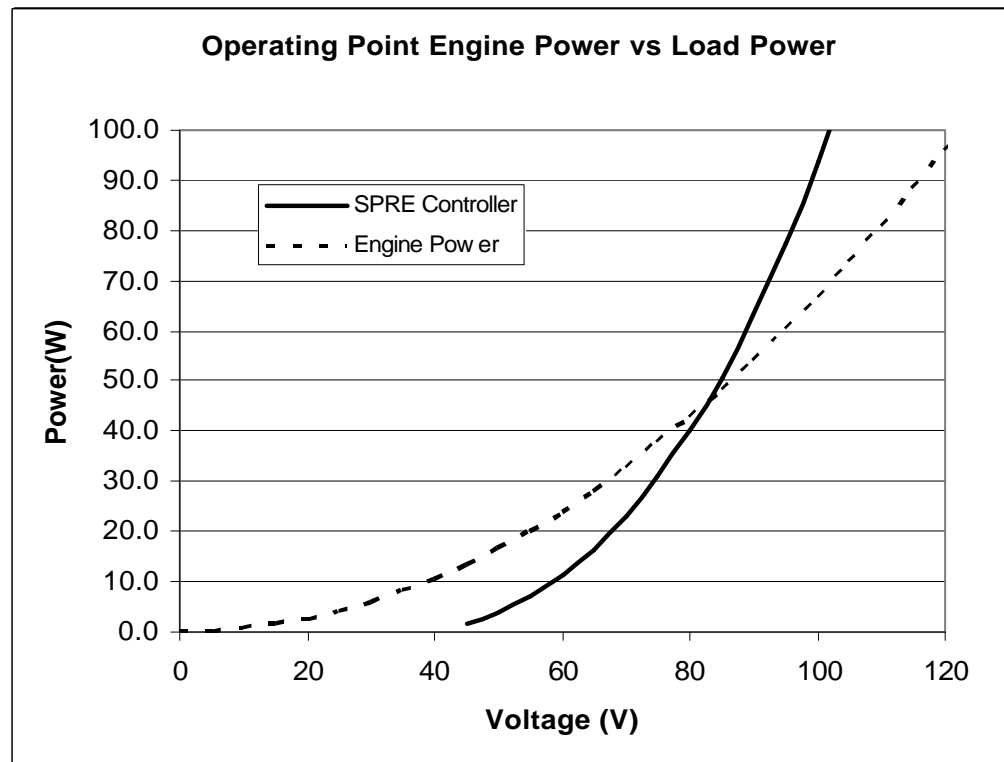

- PID Control feature on original

2. GRC Digital Controller

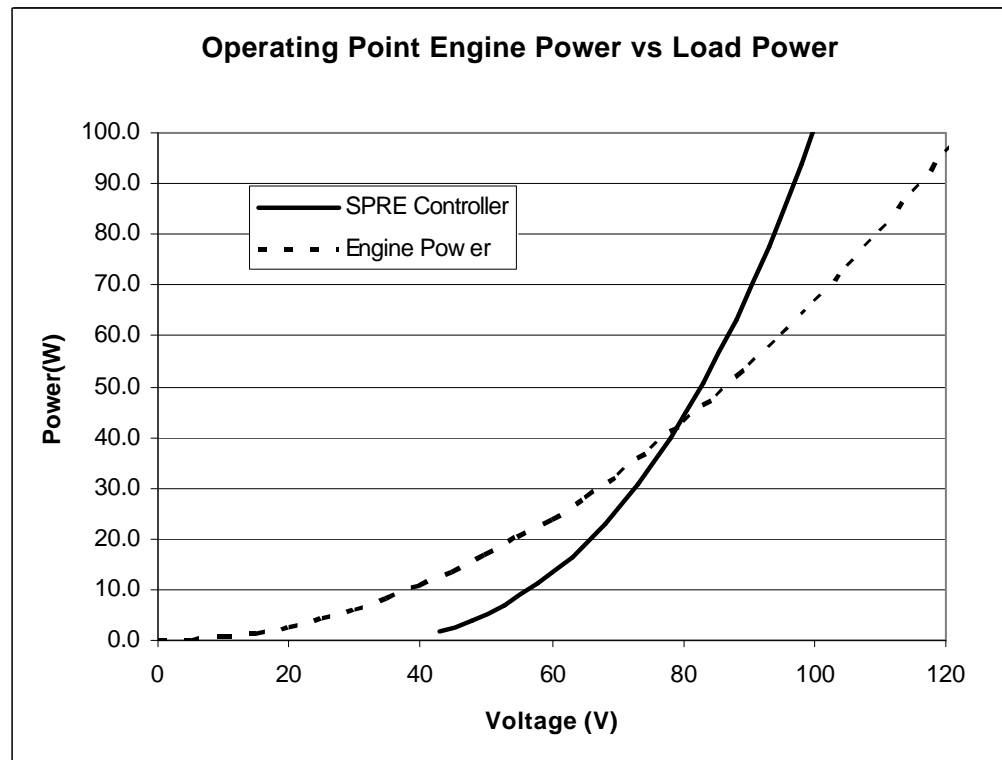

- PID Control feature on original

2. GRC Digital Controller

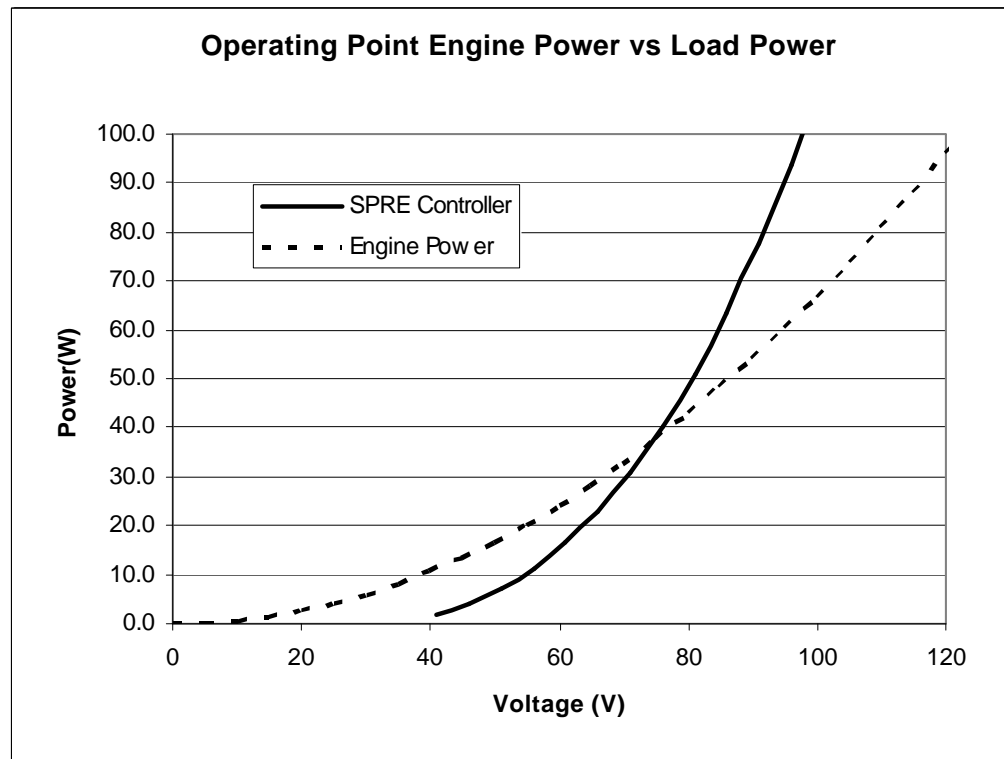

- PID Control feature on original

2. GRC Digital Controller

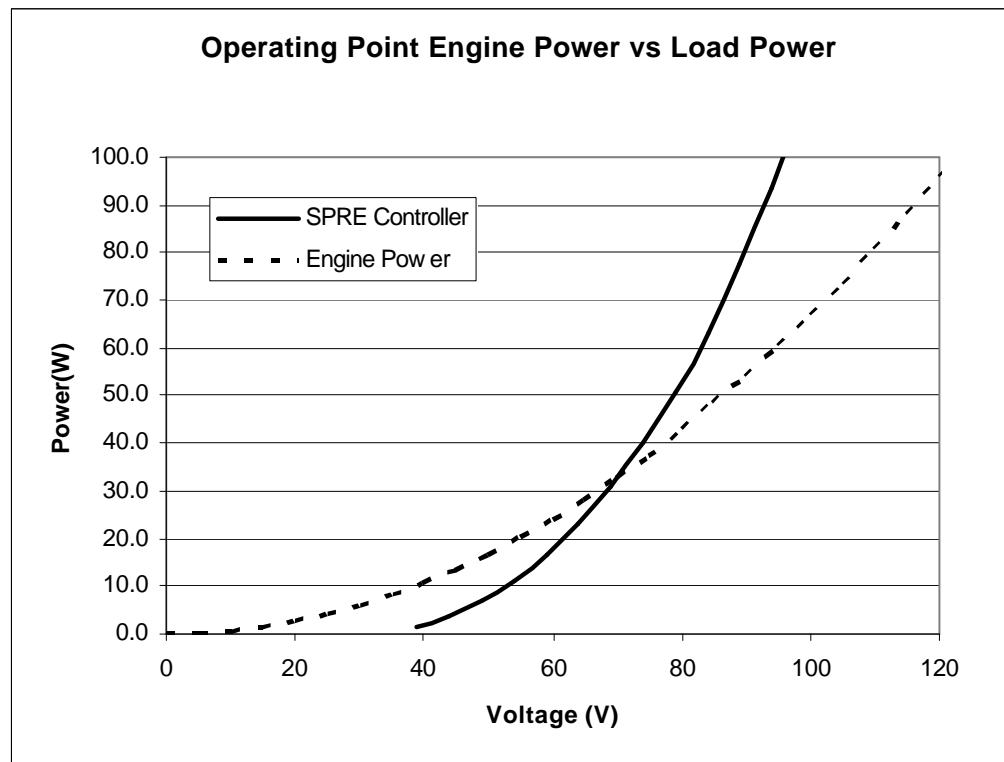

- PID Control feature on original

3. GRC 2nd Gen Digital Controller

- Adjusts Parasitic Resistance to Maintain Setpoint

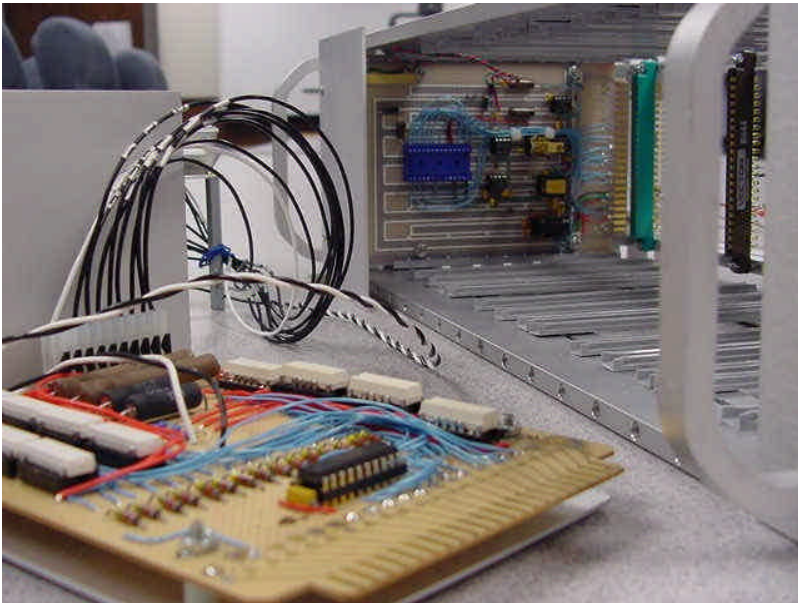

```
Calc:
Rcorr:=256000/(Verr/Vref*2047)
Prr:=pr* Rcorr/abs(Prr+Rcorr)
```

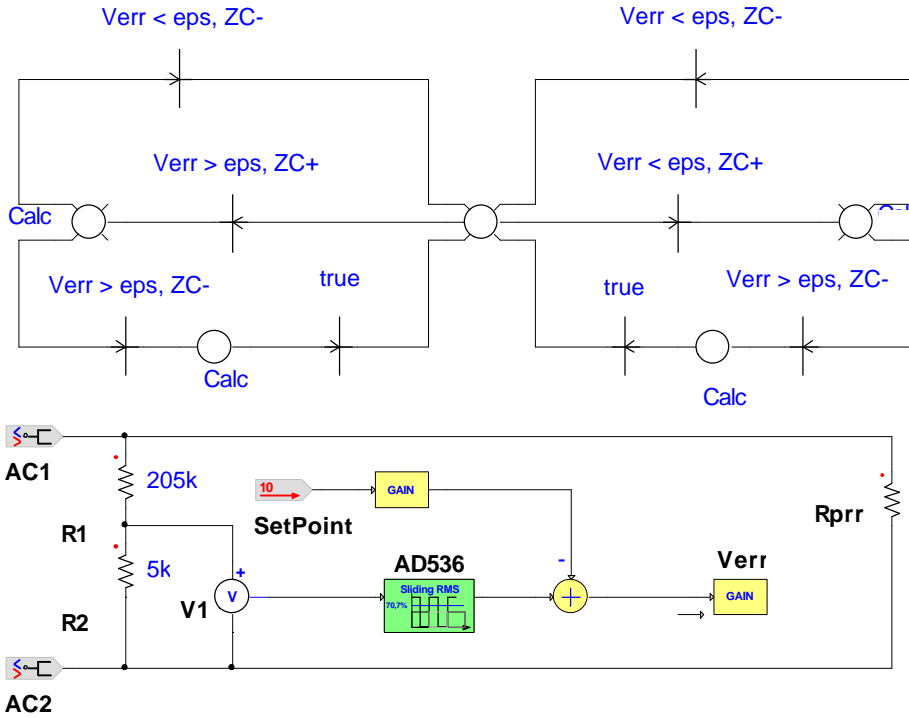

3. GRC 2nd Gen Digital Controller

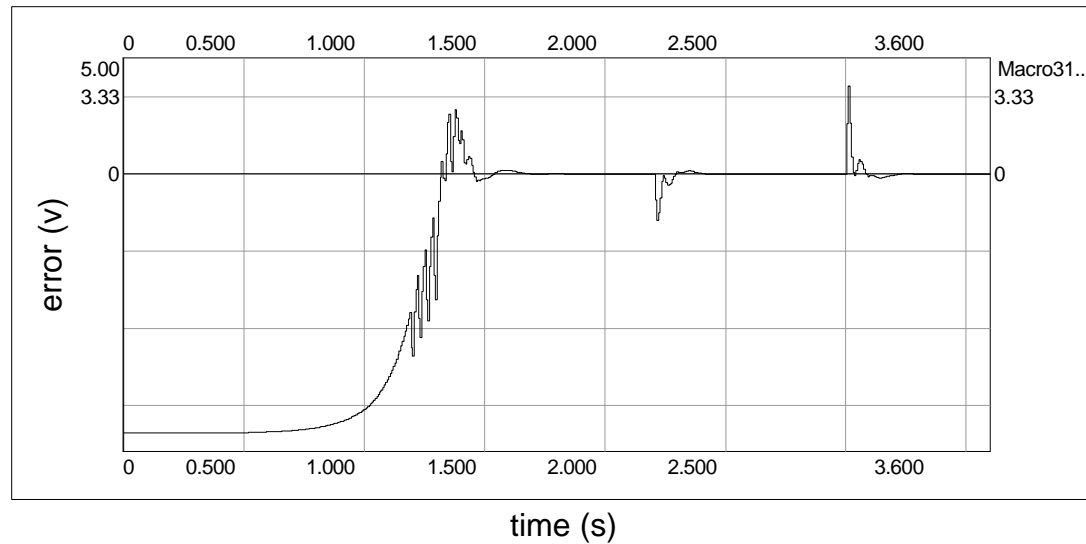

- Disturbance rejection
- Management of Startup transient
- Overshoot

3. GRC 2nd Gen Digital Controller

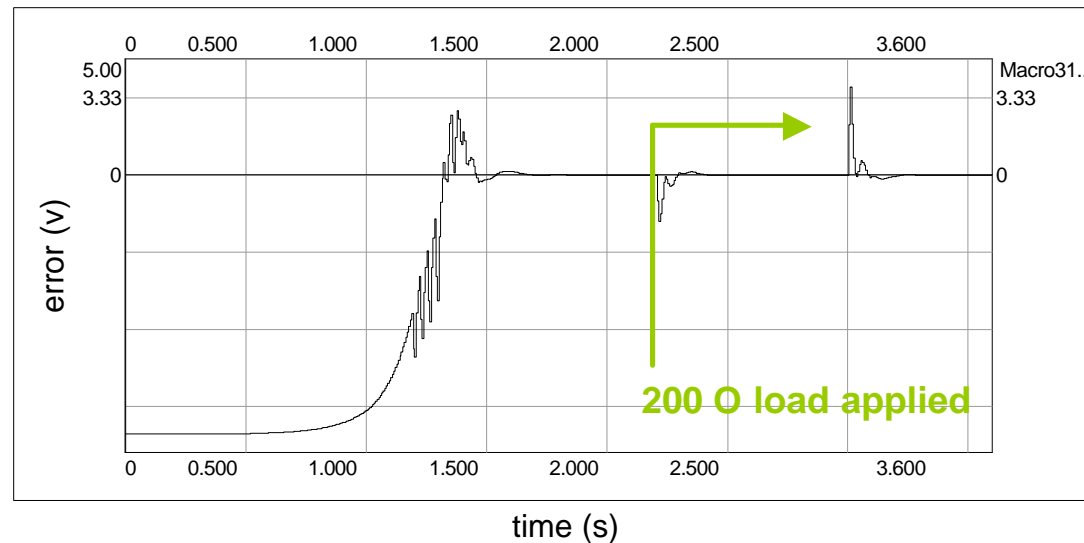

- Disturbance rejection
- Management of Startup transient
- Overshoot

3. GRC 2nd Gen Digital Controller

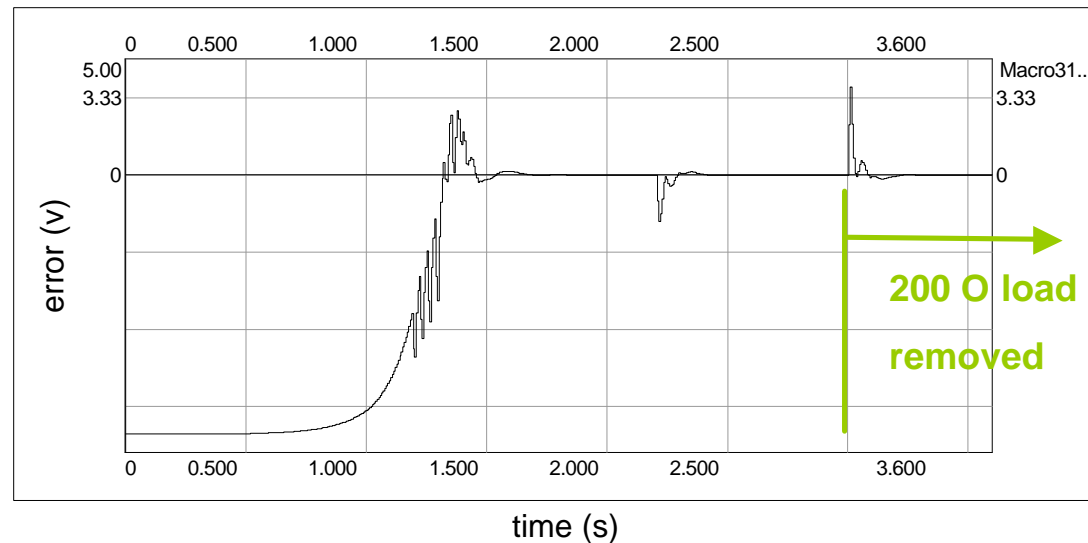

- Disturbance rejection
- Management of Startup transient
- Overshoot

4. GRC Advanced Controller

- Power factor correcting
 - No Tuning Capacitors
- Follows reference current
- Operate convertors in parallel or independently
 - Manage vibration like cryocoolers

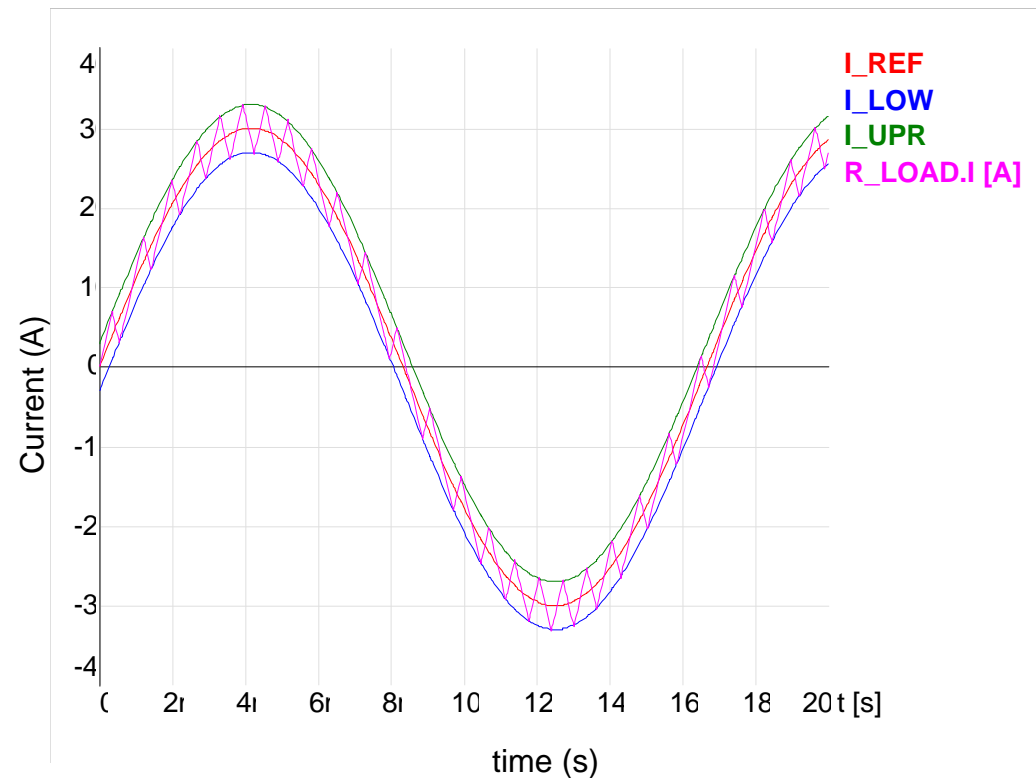

4. GRC Advanced Controller

- EMF Data from piston position sensor

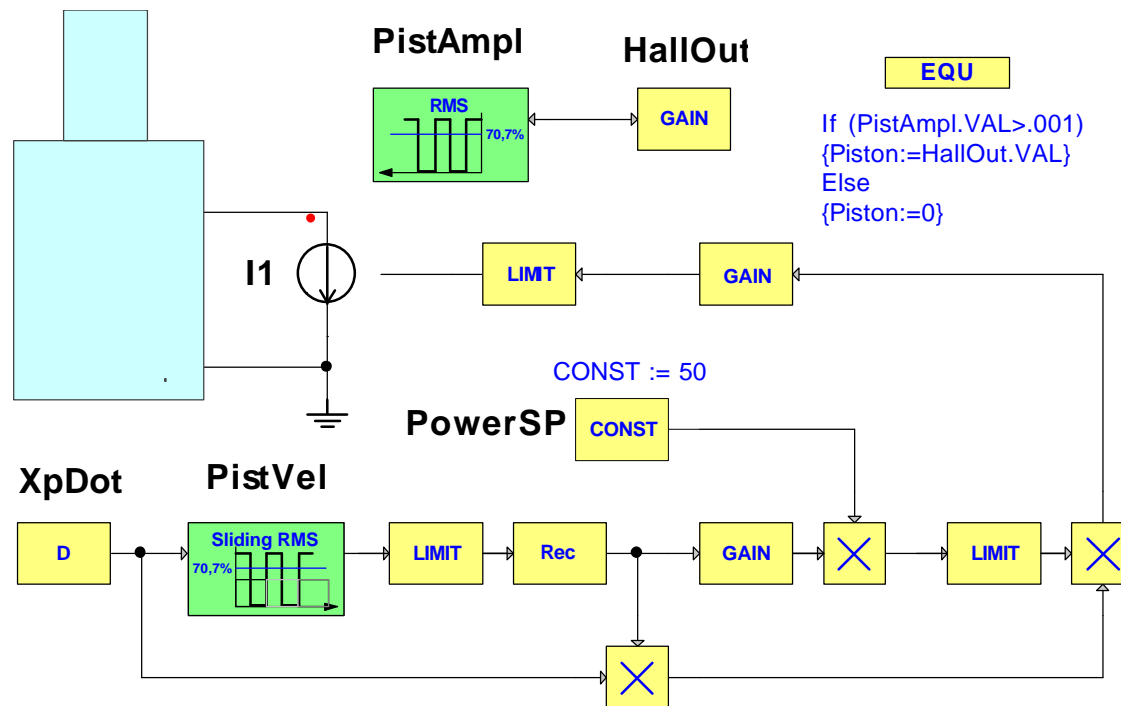

Summary

- Recognized work to date on Free-piston Stirling convertor control
- Discussed control concept
- Covered the types of controller studied at GRC
 - STC Zener Diode
 - GRC Digital (SP-100 heritage)
 - GRC 2nd Generation Digital
 - GRC Advanced (P-F correcting, PWM)

Future Plans

- Use the model to develop controllers capable of reducing vibration of paired convertors. (cf Kopasakis & Cairelli)
- Incorporate 3D FEM of Alternator electromechanics into Simplorer model.
- Develop a Sage interface to improve accuracy of thermodynamics used in the model.

Acknowledgement

- The work described in this paper was performed for the Office of Space Science (Code S) and the Office of Aerospace Technology (Code R) at NASA Headquarters, both of which provided funding for these efforts.
- The author acknowledges with appreciation the efforts and manuscript comments of Jeffrey Schreiber of GRC, Ed Lewandowski of Sest, Inc. and Scott Gerber of Zin Technologies.