



# Power System Design with Ansoft EM Tool Suite

**Scott Stanton**  
[stanton@ansoft.com](mailto:stanton@ansoft.com)  
Pittsburgh, PA

**Jian Huang**  
[jhuang@ansoft.com](mailto:jhuang@ansoft.com)  
San Jose, CA

sponsored by:



**automotive  
engineering**  
INTERNATIONAL

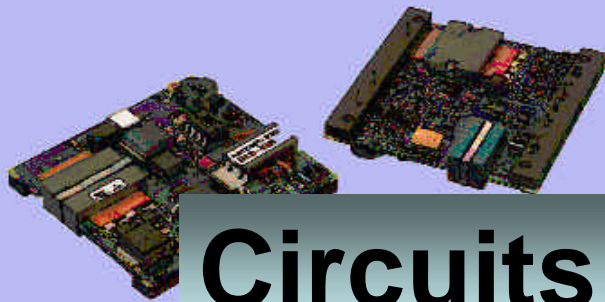

**Circuits**



DC **MOSFET**



**Transformer**



**Power Converter**

# Multi Domain Design

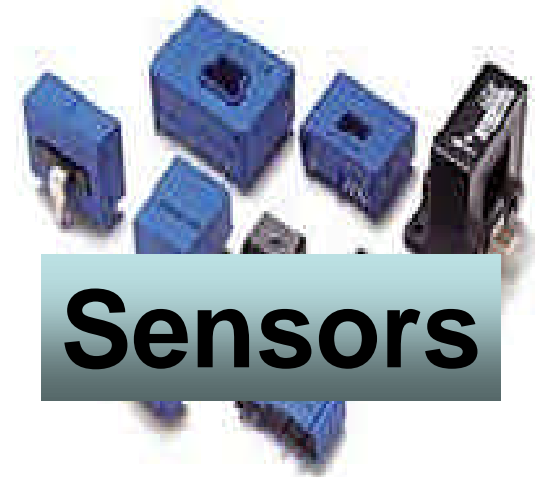

**Sensors**

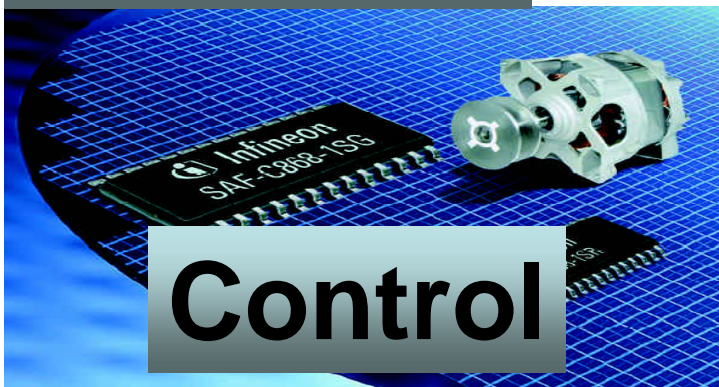

**Control**

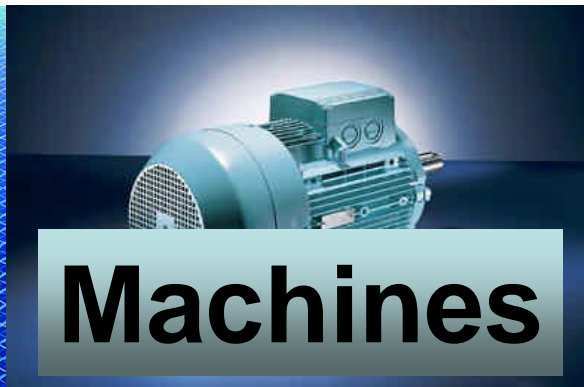

**Machines**

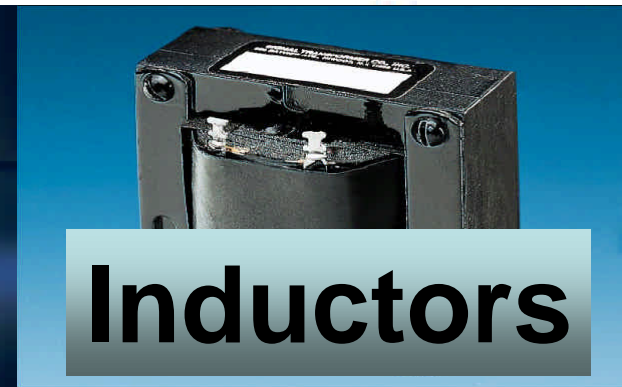

**Inductors**

# The Challenge

Predicting the performance of the system in advance of building a prototype is needed to maintain a competitive advantage



*automotive*  
**engineering**  
internacional

AUTOMOTIVE ELECTROMECHANICAL  
SIMULATION **WORKSHOP** 2004

# Ansoft Tool Suite

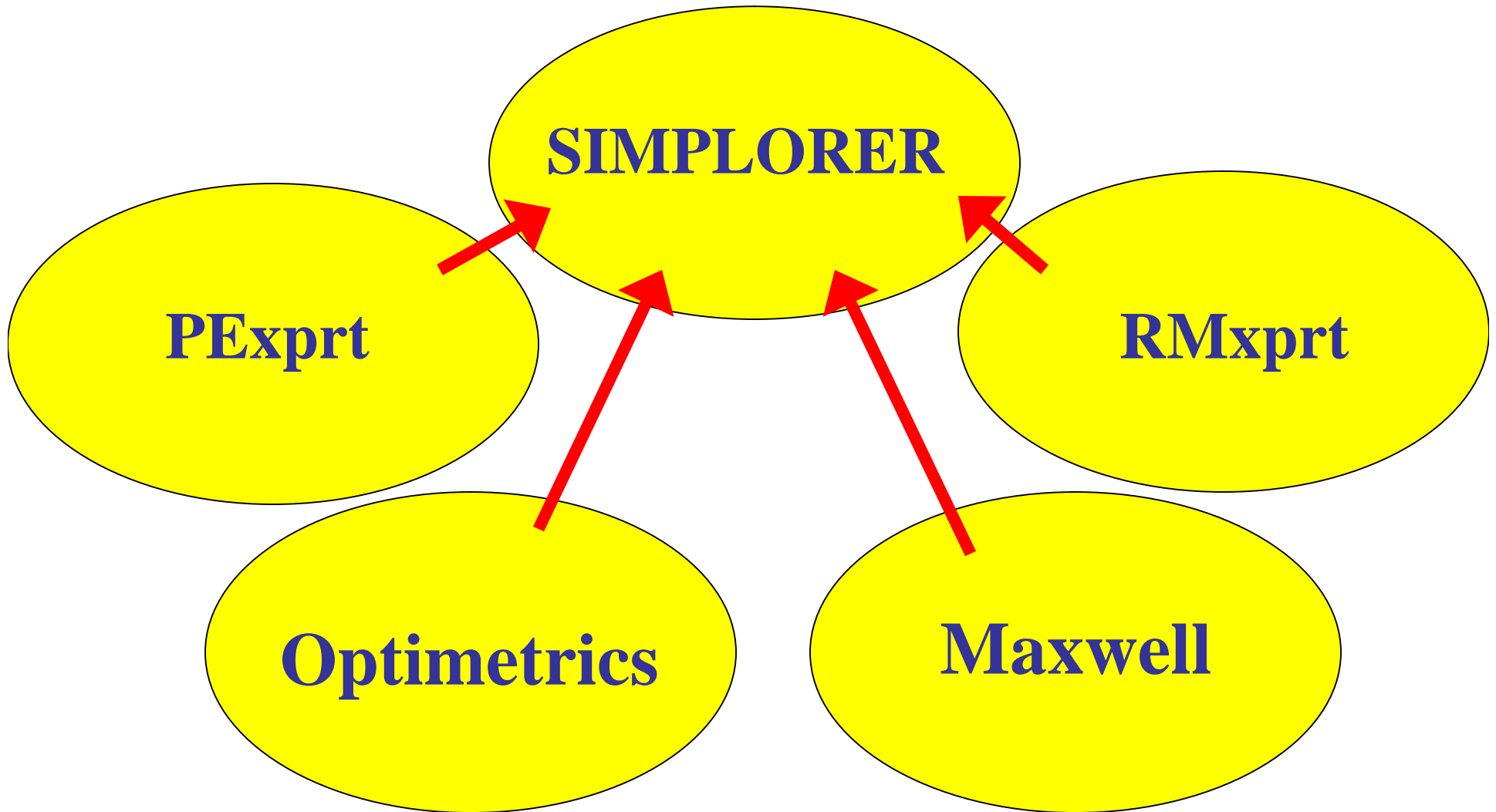

# Integrated Design Flow

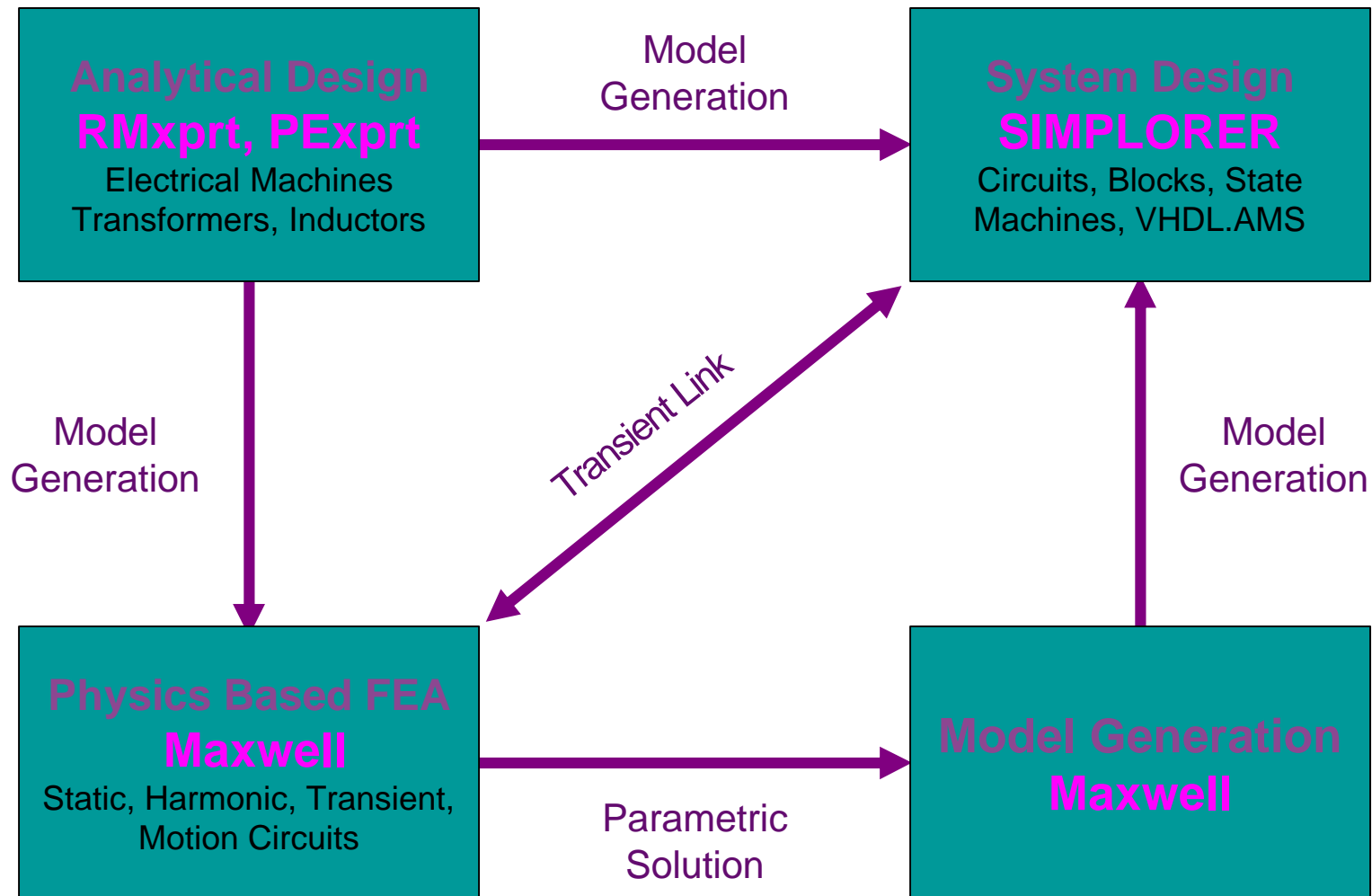

# The Power System structure

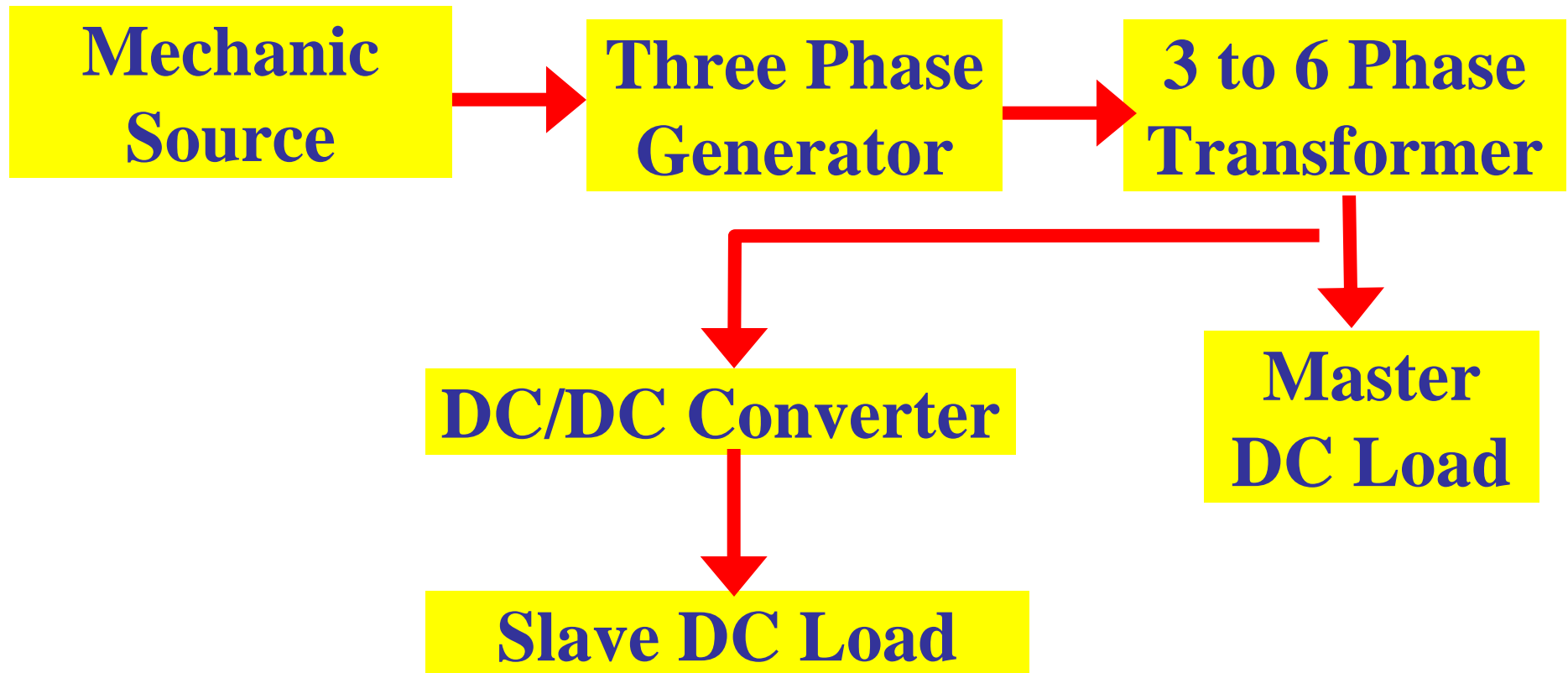

# Three Phase to Six Phase Transformer

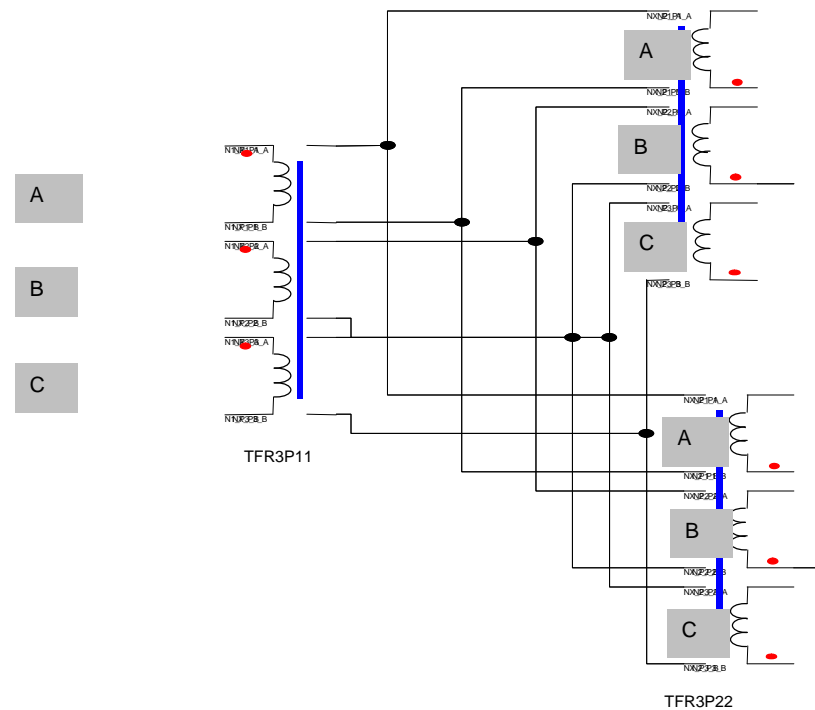

# DC/DC Converter to Power Slave Load

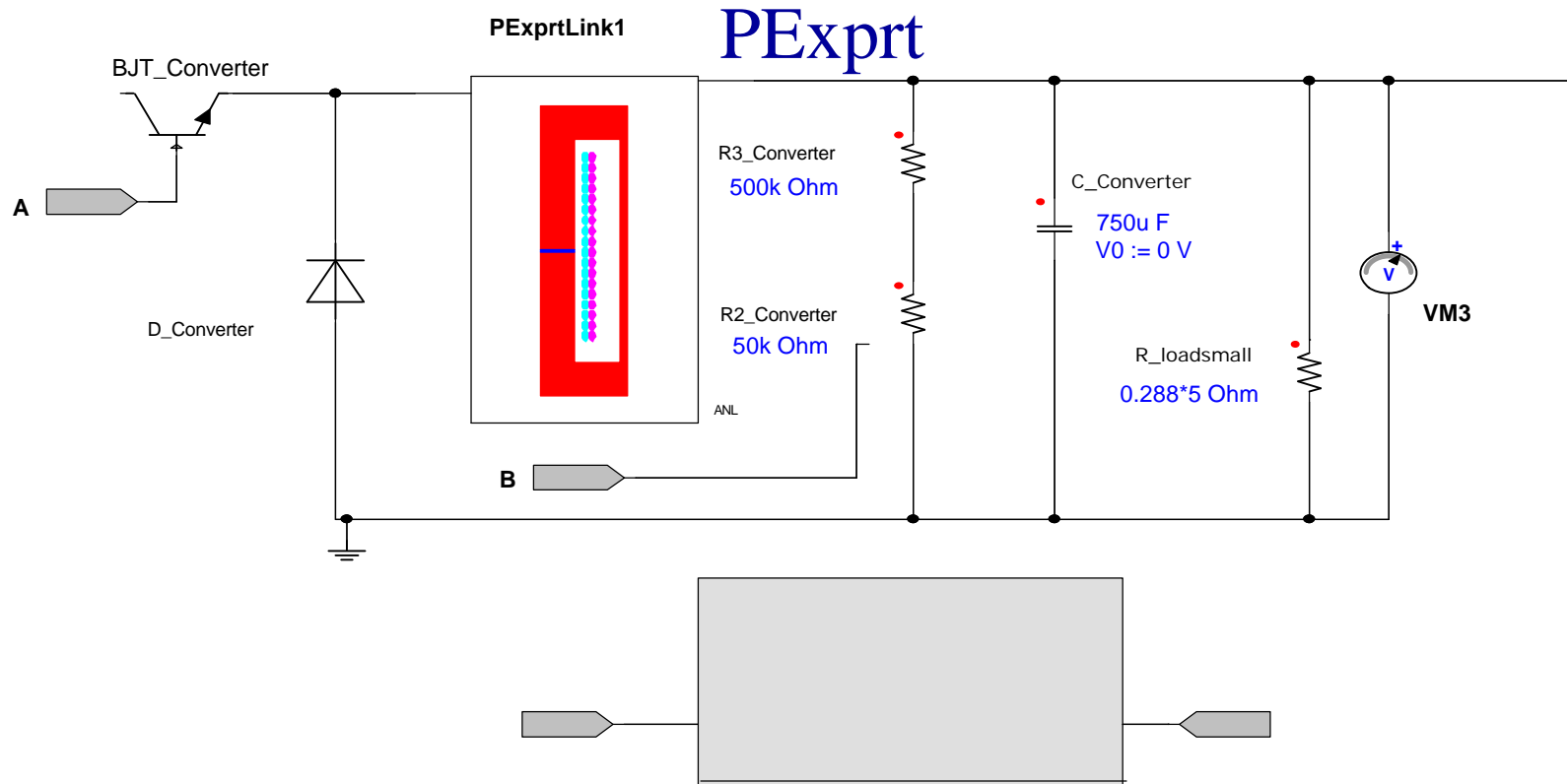

# Actuator to Switch on Control System

Maxwell 3D with  
Optimetrics ECE

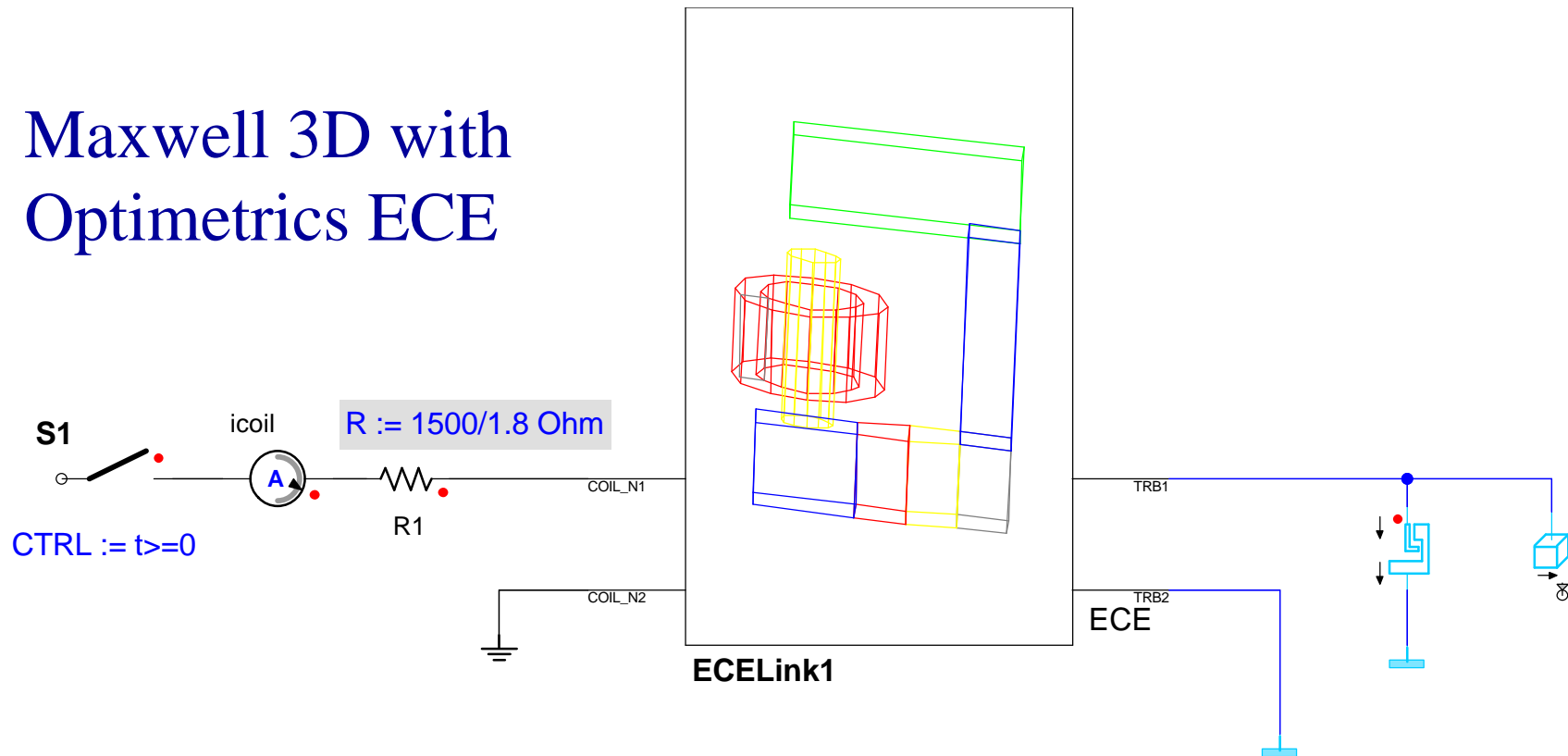

# Actuator – Component Level Model

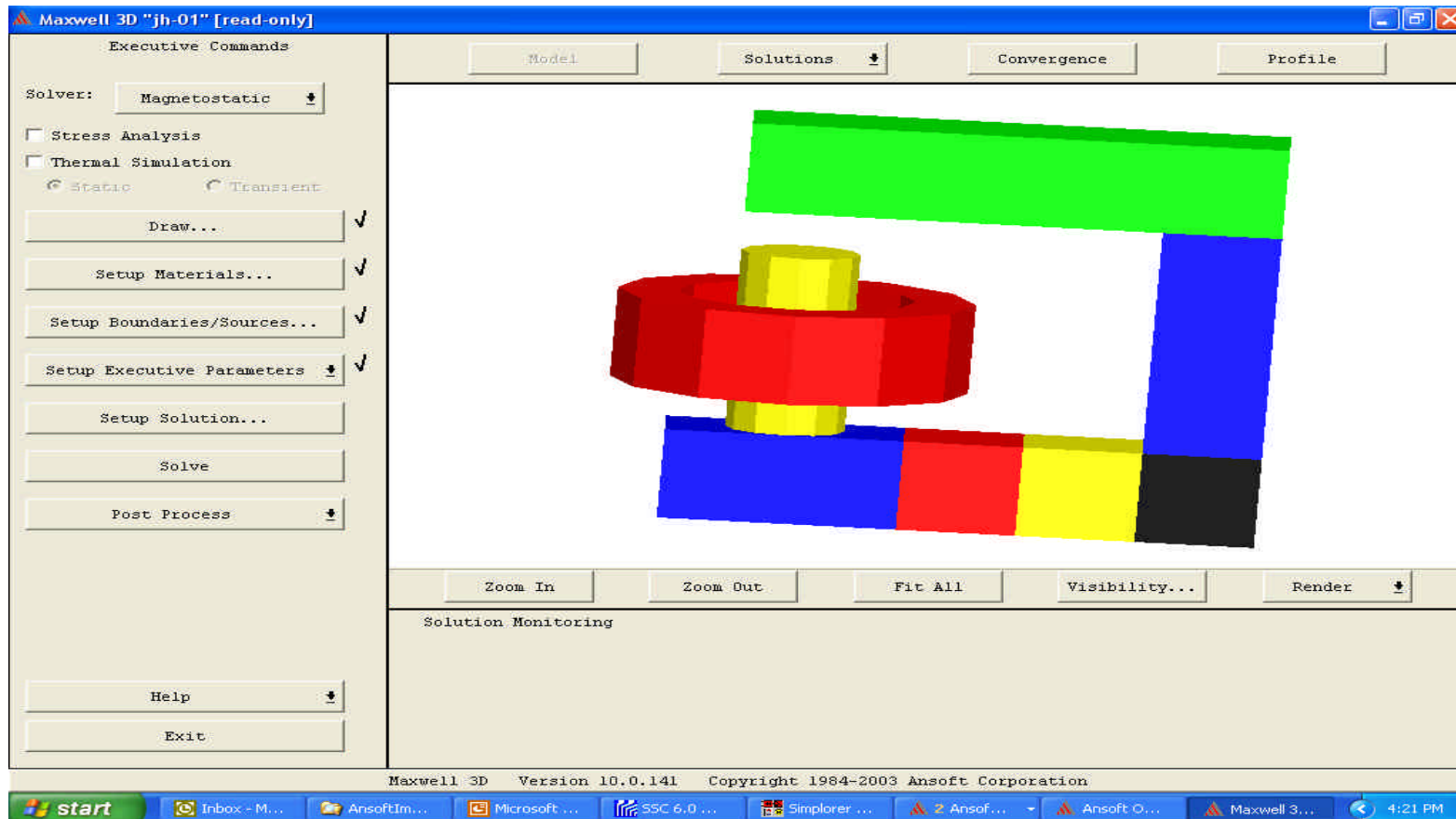



# Complete System Simulation

## Generator Voltage

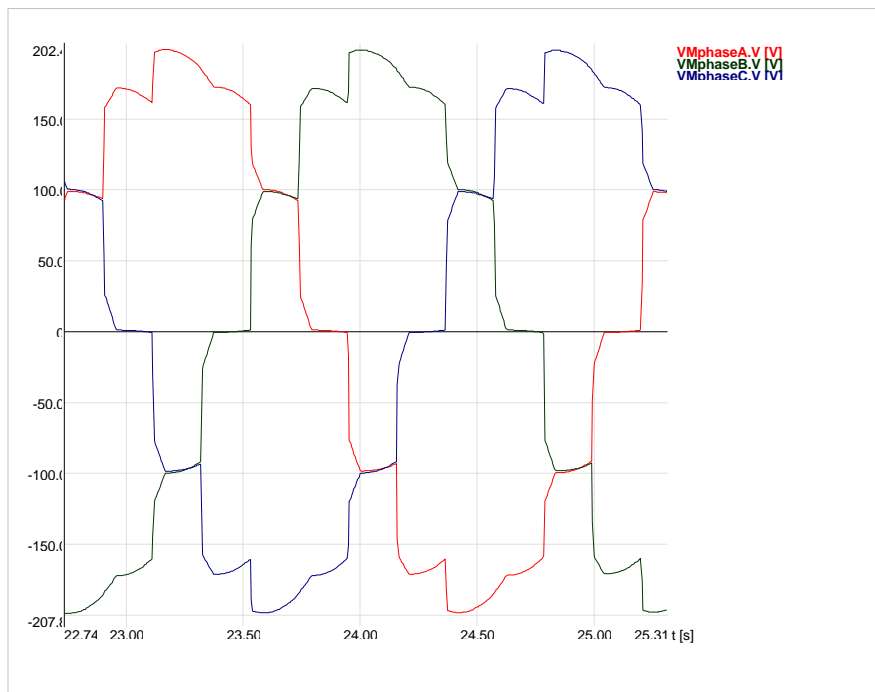

## Generator Current

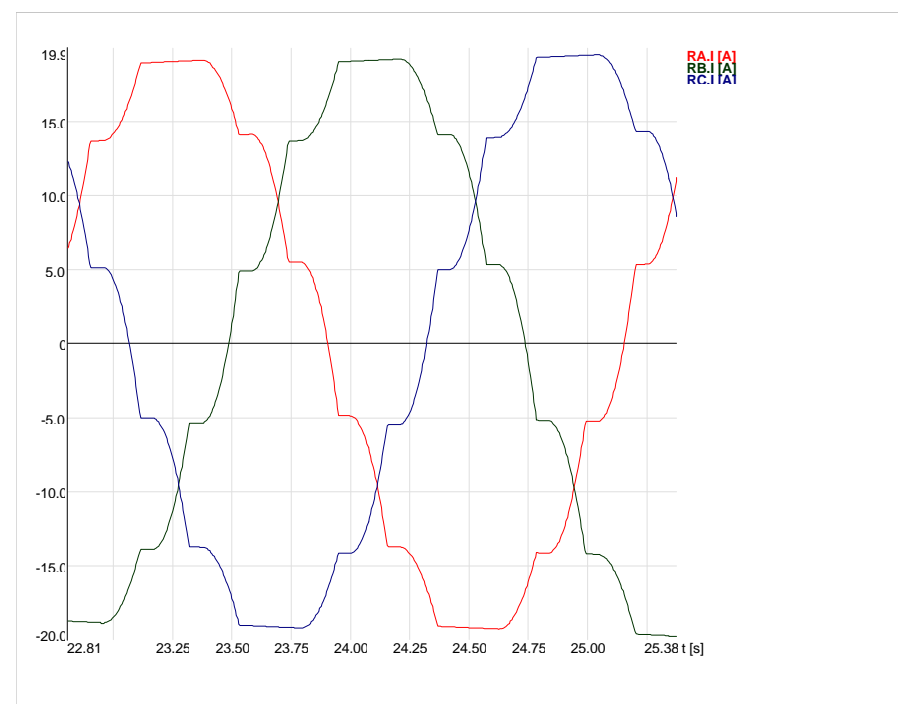

# Complete System Simulation

## DC Input / Output

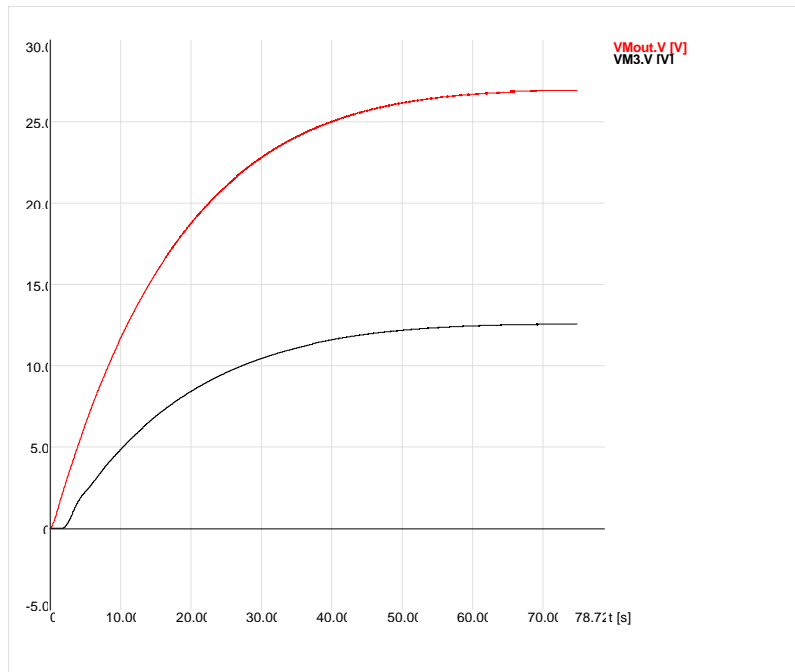

## Transformer Current

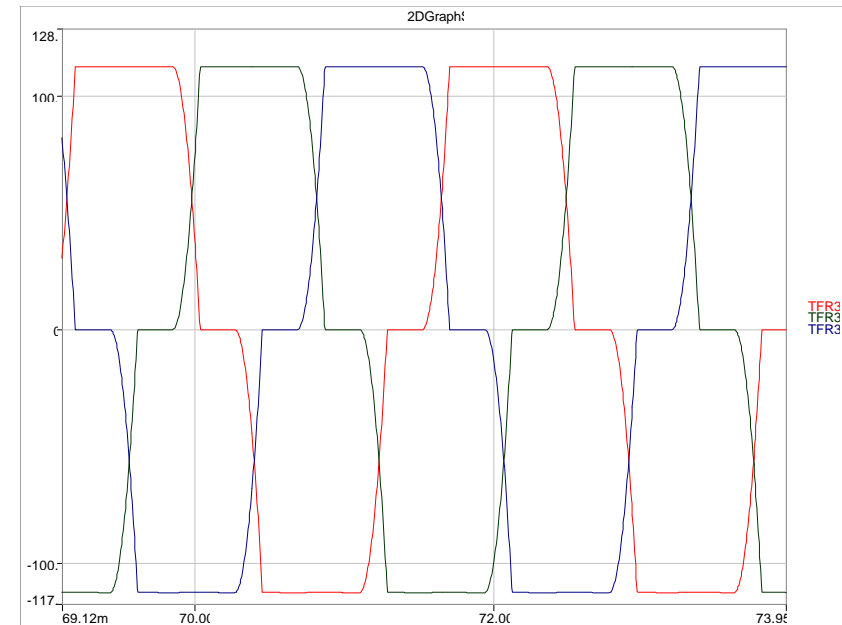

# Complete System Simulation

## Actuator Current

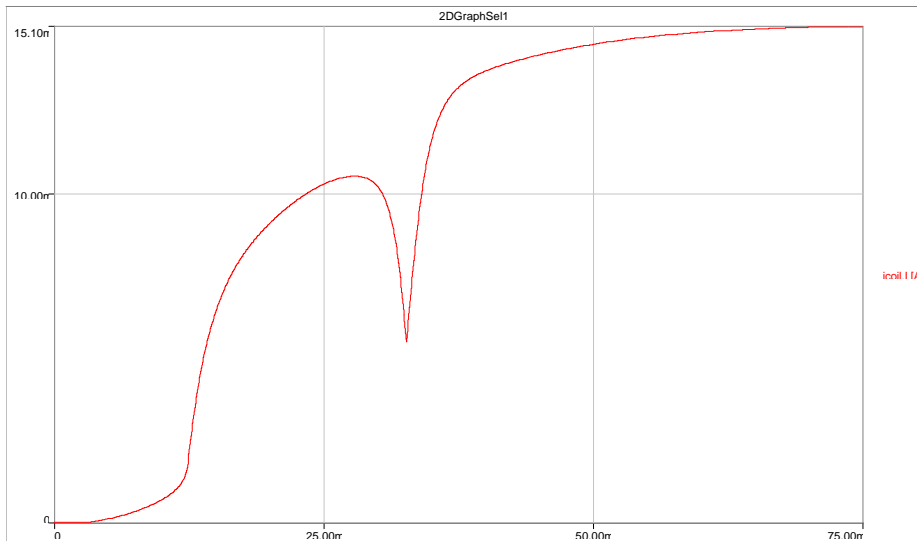

## Actuator Position

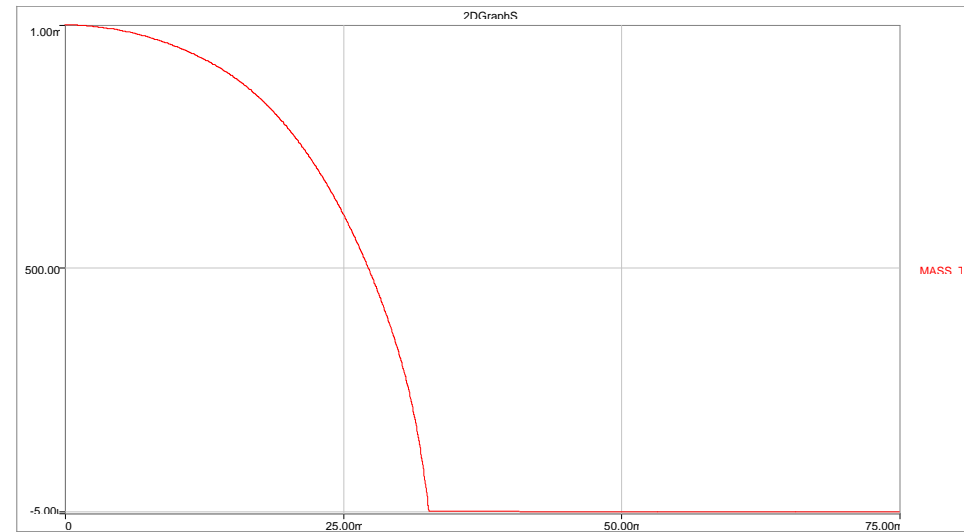

automotive  
engineering  
internacional

AUTOMOTIVE ELECTROMECHANICAL  
SIMULATION **WORKSHOP 2004**